



Prices effective February 5, 2018

Published March 2018

# Public Office Landscape®

<b>Introduction</b>	<b>page 2</b>
<b>Public Office Landscape®</b>	<b>3</b>
Seating	5
Desking and Storage	12
Power	30
Tables	47
Space Delineation	59
<b>Indices</b>	<b>63</b>
By Name	63
By Number	65
<b>Appendices</b>	
20-Day or Less/Assigned Lead-Time Order Information	
Customer's Own Material Order Information-Workspaces	
Proprietary Textiles Application Chart-Workspaces	
Proprietary Textile Colors-Workspaces	
Customer's Own Material/Customer's Own Leather Order Information-Seating	
Proprietary Textiles Application Chart-Seating	
Proprietary Textile Colors-Seating	
<b>For the latest materials information, refer to the Materials pages on HermanMiller.com.</b>	

# Introduction

## A Note on the Organization of This Book

There are a few signals that will help you understand the organization of this book. Once you know them, you should be able to find your way around easily.

### Like a newspaper, this book is formatted with columns of text and illustrations that run vertically.

Information wraps from one column to the next and continues for as many pages as it needs to.

### Black bars are clues.

A black bar at the top of a page signals the start of information about a product.

This information is divided into two sections, each signaled by a black bar. Product Information includes a description, additional notes, and dimensional drawings. Specification Information, which always begins at the top of a column, includes a series of steps. Each step represents a decision you need to make in order to complete your product number. Steps must be followed sequentially. The number of pages needed to complete information on a product varies; some will be complete in one page; others may fill three or four pages. Just continue going through the steps until you run into the next product, signaled by the black bar at the top of the page.

Black tabs running along the outside edge of the page help you locate what section you are in or what section you want to go to. You can thumb forwards or backwards to find a section; tabs and text appear on both sides of the page.

The additional pages in the back of the book include the appendices and indices. They are signaled by a long black bar running along the outside edge of the page.

### The index is presented two ways.

The first index is in alphabetical order by product name. It can be helpful if you are new to the products and numbering scheme or if you are looking for a type of product, such as work chair or round table.

The second index is by product number. It lists, in alphanumeric order, the base product number, typically a five-digit number.

## General Information

This book is effective February 5, 2018, subject to change without notice. Products may be purchased from authorized Herman Miller dealers who will quote prices upon request. For more information about our products and services or to see a list of dealers, visit [www.HermanMiller.com](http://www.HermanMiller.com).

All prices are list prices. Additional services, such as planning services, design, storage, and installation, are not included and must be added to these prices when the additional services are requested.

Illustrations, specifications, and prices are based on the latest information at the time of publication. The right is reserved to make changes at any time without notice in prices, fabrics, finishes, materials, specifications, and models, and also to discontinue models and finishes.

Dimensions shown in the drawings are engineering drawing dimensions rounded up to the nearest  $\frac{1}{8}$ ". Product is shipped set up or knocked down. Products that include "Shipped knocked down" in the description require some assembly. If this statement does not appear in the description, the product is shipped assembled.

Service problems are normally handled by a Herman Miller authorized dealer. Where this cannot be accomplished on a local level, service problems should be referred to the Customer Care Representative for your region, Herman Miller, Inc., Zeeland, Michigan 49464.

### 20-Day or Less/Assigned Lead-Time Shipments

All products and options in this price book not designated by an Assigned Program icon  will ship in **20 business days or less** after being acknowledged by Herman Miller.

Products and options designated by an  are on the assigned lead-time program and may ship in 20 days, less than 20 days, or more than 20 days from order acknowledgement.

**Seating**

**Desking and Storage**

**Power**

**Tables**

**Space Delineation**



# Social Chair

BVS1N.

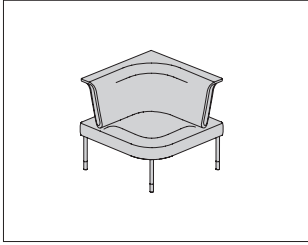

### Product Information

#### Description

This chair has an upholstered foam seat on an expanded polypropylene base, with a Network-wrapped suspension back. The chair can be freestanding next to a desk or connected to other social chairs or café tables. It accepts the attachment of screens. It comes with legs for freestanding applications or without legs when attached to other chairs. Legs have glides that provide up to 2" of adjustment.

#### Notes

- Chair supports attachment of 2 screens.
- When specified without legs, order seating legs (BVS3.) separately.
- Network color and back loop frame color will match.
- Seat fabric is railroaded.
- Customers Own Material can only be specified for seat fabric. See Customers Own Material Order Information in appendices.
- Seat accepts Customer's Own Material (COM). Yardage is estimated for nondirectional 54"-wide fabrics. Order 2.16 yards of fabric per cushion. For information on multiple quantities or directional fabrics, contact COM Department. See Order Information in Appendices.

#### Dimensions

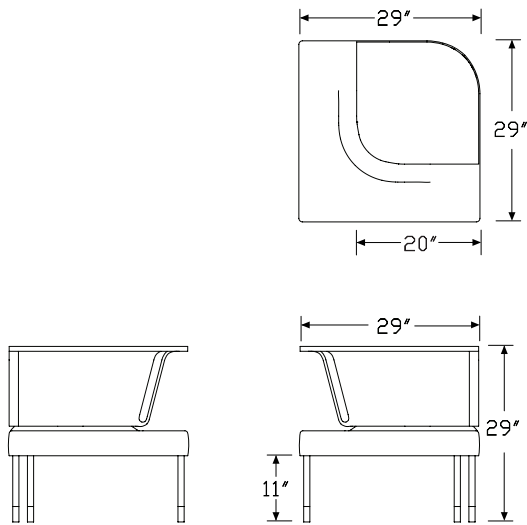

### Specification Information

#### Step 1.

**BVS1N.**

#### Step 2. Seat Style

- L** left
- R** right

#### Step 3. Leg Option

- L** legs
- N** no legs

#### Step 4. Fire Retardancy

- For not fire retardant (\*), skip this step.*
- not fire retardant

#### Prices for Steps 1-4.

		*
<b>BVS1N.L</b>	<b>L</b>	\$1857
	<b>N</b>	\$1857
	<b>R L</b>	\$1857
	<b>N</b>	\$1857

#### Step 5. Glide Option

- For legs (L)*
- C** nylon glide, carpet floors + \$0

#### Step 6. Leg Finish

- For legs (L)*
- G1** graphite + \$0
- 91** white + \$0
- MS** metallic silver + \$0

#### Step 7. Glide Finish

- For graphite (G1)*
- BK** black + \$0
- For white (91)*
- 8Q** folkstone grey + \$0
- For metallic silver (MS)*
- 63** fog + \$0

# Social Chair *continued*

Step 8. Back Frame Finish		
<b>91</b>	white	+\$0
<b>G1</b>	graphite	+\$0
<b>RO</b>	red	+\$0
<b>97</b>	twilight	+\$0
<b>63</b>	fog	+\$0
<b>79</b>	green apple	+\$0
<b>WBY</b>	wild berry	+\$0

Step 9. Back Knit Color		
-------------------------	--	--

<i>For white (91)</i>		
<b>1A901</b>	warm white	+\$0

<i>For white (91)</i>		
<b>1DL01</b>	dialogue light brindle <input type="checkbox"/>	+\$0
<b>1DL02</b>	dialogue dark brindle <input type="checkbox"/>	+\$0

<i>For graphite (G1)</i>		
<b>1A907</b>	graphite	+\$0

<i>For graphite (G1)</i>		
<b>1DL01</b>	dialogue light brindle <input type="checkbox"/>	+\$0
<b>1DL02</b>	dialogue dark brindle <input type="checkbox"/>	+\$0

<i>For red (RO)</i>		
<b>1A903</b>	red	+\$0

<i>For twilight (97)</i>		
<b>1A906</b>	twilight blue	+\$0

<i>For fog (63)</i>		
<b>1DL01</b>	dialogue light brindle <input type="checkbox"/>	+\$0
<b>1DL02</b>	dialogue dark brindle <input type="checkbox"/>	+\$0

<i>For fog (63)</i>		
<b>1A902</b>	fog	+\$0

<i>For green apple (79)</i>		
<b>1A905</b>	green apple	+\$0

<i>For wild berry (WBY)</i>		
<b>1A904</b>	wild berry	+\$0

Step 10. Seat Fabric	
Price Category 1	+\$0
Price Category 2	+\$25
Price Category 3	+\$46
Price Category 4	+\$90
Price Category 5	+\$134

# Sectional Seating

BVS2N.

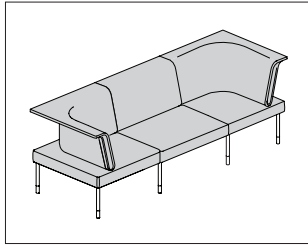

### Product Information

#### Description

The sectional seat comes in straight, right-corner, and left-corner styles. It has an upholstered foam seat on an expanded polypropylene base, with a Network-wrapped suspension back. Sectional seats connect to other sectional seats and social chairs and accept the attachment of screens.

#### Notes

Order seating legs (BVS3.) separately.

Corner-style seats support 2 screens. Straight-style seats support 1 screen.

Network color and back loop frame color will match.

Seat fabric is railroaded.

Customers Own Material can only be specified for seat fabric. See

Customers Own Material Order Information in appendices.

Seat accepts Customer's Own Material (COM). Yardage is estimated for nondirectional 54"-wide fabrics.

Seat style—Yardage

CR—2.16

CL—2.16

29—2.21

For information on multiple quantities or directional fabrics, contact COM Department. See Order Information in Appendices.

### Dimensions

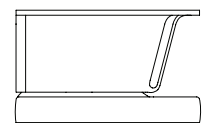
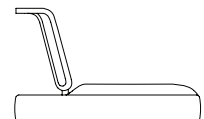
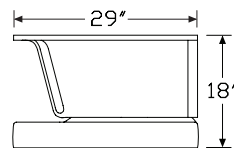
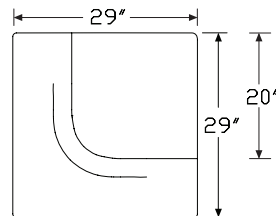
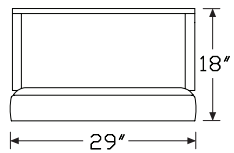
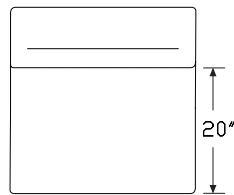

# Sectional Seating *continued*

Specification Information	
Step 1.	
<b>BVS2N.</b>	
Step 2. Seat Style	
<b>CR</b>	corner right
<b>CL</b>	corner left
<b>29</b>	straight, 29"
Step 3. Fire Retardancy	
<i>For not fire retardant (*), skip this step.</i>	
not fire retardant	
Prices for Steps 1-3.	
	*
<b>BVS2N.CR</b>	\$1857
<b>CL</b>	\$1857
<b>29</b>	\$1857
Step 4. Back Frame Finish	
<b>91</b>	white +\$0
<b>G1</b>	graphite +\$0
<b>RO</b>	red +\$0
<b>97</b>	twilight +\$0
<b>63</b>	fog +\$0
<b>79</b>	green apple +\$0
<b>WBY</b>	wild berry +\$0
Step 5. Back Knit Color	
<i>For white (91)</i>	
<b>1A901</b>	warm white +\$0
<i>For white (91)</i>	
<b>1DL01</b>	dialogue light brindle <input type="checkbox"/> +\$0
<b>1DL02</b>	dialogue dark brindle <input type="checkbox"/> +\$0
<i>For graphite (G1)</i>	
<b>1A907</b>	graphite +\$0
<i>For graphite (G1)</i>	
<b>1DL01</b>	dialogue light brindle <input type="checkbox"/> +\$0
<b>1DL02</b>	dialogue dark brindle <input type="checkbox"/> +\$0
<i>For red (RO)</i>	
<b>1A903</b>	red +\$0

<i>For twilight (97)</i>	
<b>1A906</b>	twilight blue +\$0
<i>For fog (63)</i>	
<b>1DL01</b>	dialogue light brindle <input type="checkbox"/> +\$0
<b>1DL02</b>	dialogue dark brindle <input type="checkbox"/> +\$0
<i>For fog (63)</i>	
<b>1A902</b>	fog +\$0
<i>For green apple (79)</i>	
<b>1A905</b>	green apple +\$0
<i>For wild berry (WBY)</i>	
<b>1A904</b>	wild berry +\$0
Step 6. Seat Fabric	
Price Category 1	+\$0
Price Category 2	+\$25
Price Category 3	+\$46
Price Category 4	+\$90
Price Category 5	+\$134



Legs

BVS3.

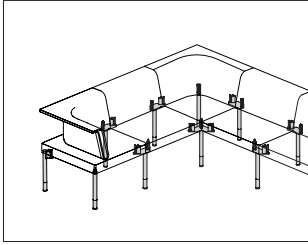

**Product Information**

**Description**

Seating legs provide 4 attachment options to accommodate the various configurations of social chairs and sectional seats. Legs have glides that provide up to 2" of adjustment.

**Notes**

When specifying trivalent chrome (47) finish option, glide color must be specified separately.

**Dimensions**

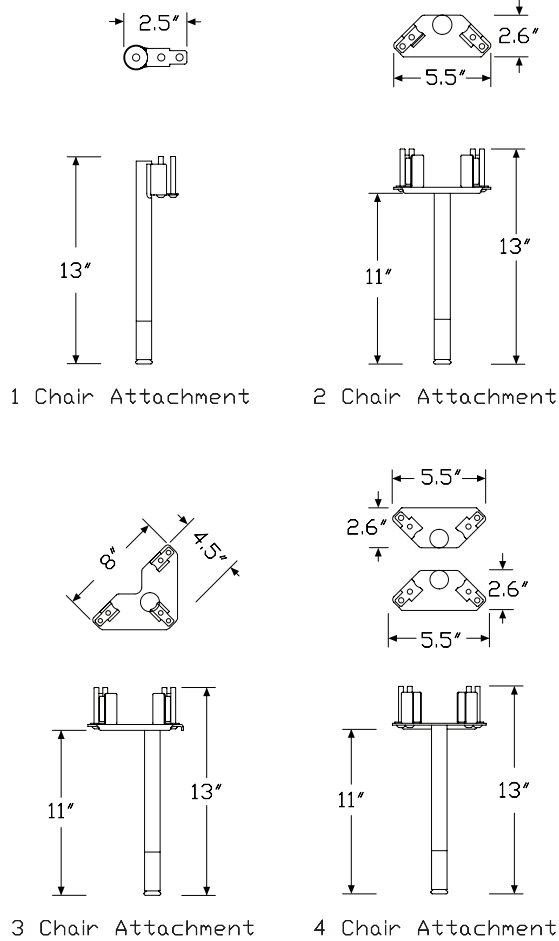

**Specification Information**

**Step 1.**

**BVS3.**

**Step 2. Leg Option**

- 1 attaches to one chair
- 2 attaches to two chairs
- 3 attaches to three chairs
- 4 attaches to four chairs

**Prices for Steps 1-2.**

<b>BVS3. 1</b>	\$54
<b>2</b>	\$79
<b>3</b>	\$111
<b>4</b>	\$159

**Step 3. Glide Option**

<b>C</b>	nylon glide, carpet floors	+\$0
----------	----------------------------	------

**Step 4. Leg Finish**

<b>91</b>	white	+\$0
<b>G1</b>	graphite	+\$0
<b>MS</b>	metallic silver	+\$0
<b>47</b>	trivalent chrome	+\$10

**Step 5. Glide Finish**

*For graphite (G1)*

<b>BK</b>	black	+\$0
-----------	-------	------

*For white (91)*

<b>8Q</b>	folkstone grey	+\$0
-----------	----------------	------

*For metallic silver (MS)*

<b>63</b>	fog	+\$0
-----------	-----	------

*For trivalent chrome (47)*

<b>BK</b>	black	<input type="checkbox"/> A	+\$0
<b>8Q</b>	folkstone grey	<input type="checkbox"/> A	+\$0
<b>63</b>	light grey	<input type="checkbox"/> A	+\$0

# Seat Back Ganging Kit

BVS4.

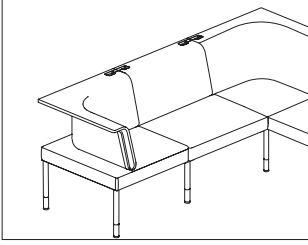

Public Office Landscape® Seating

## Product Information

**Description**  
This seat back ganging kit aligns 2 chairs that are side-by-side.

## Dimensions

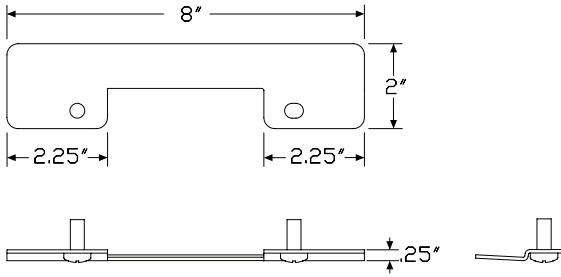

## Specification Information

**Step 1.**  
**BVS4.** \$30

**Step 2. Leg Option**  
2 ganging kit for 2 seats +\$0

# Seat Back Alignment Clip

BVS5.

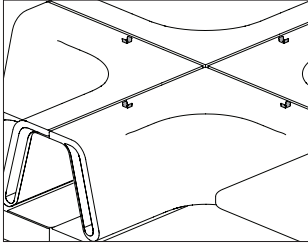

### Product Information

#### Description

This seat back alignment clip aligns 2 chairs that are back-to-back.

#### Dimensions

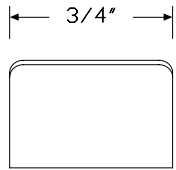
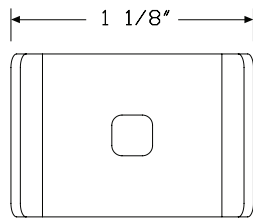

### Specification Information

#### Step 1.

**BVS5.1**

\$15

# Desk

BVD1.

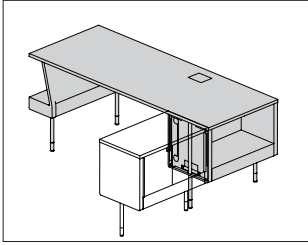

## Product Information

### Description

Desks have 4 legs and are intended to connect with other desks and connecting bins. Desks have a laminate, veneer, or Formcoat® squared-edge work surface with a painted steel understructure bin on 1 side and a steel shelf with a bag hook on the other side. Desks will support a screen on the shelf side, and on the bin side when the bin does not have doors, and will accommodate desktop dividers. Understructure bins come in left or right orientation, with or without doors. Bin divider included. Legs have glides that provide up to 2" of adjustment.

Power bridge desk allows power to be run from desk-bin side to L-shelf side of the desk to accommodate powering other desks or café surfaces from a single power entry point. The desk bin and L-shelf have the same appearance as on the power access desk, but have different internal structures and components to support power across the desk.

### Notes

To connect desk to a connecting bin (BVD2.) or another desk (BVD1.), order desk and bin ganging plate (BVD5.C) separately.

All connecting bins (BVD2.) require the use of both bin-to-bin and desktop-to-desktop ganging plates. Order desk and bin ganging plate (BVD5.C) separately.

The exposed end of the understructure bin requires a desk and bin finishing kit (BVD4.), ordered separately.

Desk accepts modular power (BVEo1., BVEo2.) through the bottom of the understructure bin.

To bring power to the surface of a desk, order Logic Mini, Grommet Mount (Y1414.) separately.

Bin divider is field installed and can be specified in a complementary color.

Grommet color is either graphite or white, matched to the work surface color.

Bag hook color is matched to shelf color.

When specifying trivalent chrome (47) leg finish, glide color is predetermined to coordinate with specified desk finish:

- Graphite (G1) desk will have black (BK) glides
- Metallic silver (MS) desk will have fog (63) glides
- White (G1) desk will have folkstone grey (8Q) glides

Power bridge desk includes cable management channel and L-shelf cover for beam connection.

Power access desk can be ordered with or without doors. The power bridge desk can only be ordered without doors, to accommodate the power bridge components.

See Planning Guide for more information about settings.

## Dimensions

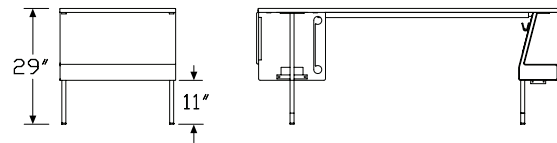
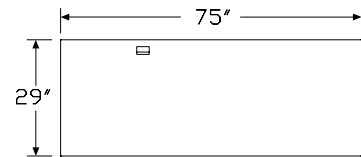

**Specification Information**

Step 1.

**BVD1.**

Step 2. Depth

**29** 29" deep

Step 3. Width

**75** 75" wide

Step 4. Power Access

**P** power access

**B** power bridge desk **A**

Step 5. Bin Orientation

**R** bin right

**L** bin left

Step 6. Bin Doors

*For power access (P)*

**D** doors

**N** no doors

*For power bridge desk (B)*

**N** no doors

Step 7. Top Material

**L** laminate top/thermoplastic edge

**T** formcoat®

**W** veneer

Prices for Steps 1-7.

	PRDL	PRDT	PRDW	PRNL	PRNT	PRNW
<b>BVD1. 29 75</b>	\$2057	2160	2469	1914	2010	2297

	PLDL	PLDT	PLDW	PLNL	PLNT	PLNW
<b>BVD1. 29 75</b>	\$2057	2160	2469	1914	2010	2297

	BRNL	BRNT	BRNW	BLNL	BLNT	BLNW
<b>BVD1. 29 75</b>	\$2075	2171	2458	2075	2171	2458

Step 8. Top Finish

*For laminate top/thermoplastic edge (L)*

<b>76</b>	light brown walnut	+\$0
<b>8Q</b>	folkstone grey	+\$0
<b>91</b>	white	+\$0
<b>98</b>	studio white	+\$0
<b>CL</b>	cool grey neutral	+\$0
<b>HF</b>	inner tone light	+\$0
<b>HM</b>	natural maple	+\$0
<b>HP</b>	light anigre	+\$0
<b>HT</b>	inner tone	+\$0
<b>HX</b>	aged cherry	+\$0
<b>HY</b>	walnut on cherry	+\$0
<b>LA</b>	light ash	+\$0
<b>LBA</b>	clear on ash	+\$0
<b>LBB</b>	oak on ash	+\$0
<b>LBC</b>	walnut on ash	+\$0
<b>LBD</b>	dark brown walnut	+\$0
<b>LBE</b>	medium red walnut	+\$0
<b>LBF</b>	neutral twill	+\$0
<b>LBG</b>	sarum twill	+\$0
<b>LBH</b>	earthen twill	+\$0
<b>LBJ</b>	graphite twill	+\$0
<b>LBK</b>	pewter mesh	+\$0
<b>LBL</b>	steel mesh	+\$0
<b>LBM</b>	crisp linen	+\$0
<b>LBN</b>	classic linen	+\$0
<b>LBP</b>	casual linen	+\$0
<b>LBQ</b>	white twill	+\$0
<b>LM</b>	mahogany	+\$0
<b>LT</b>	light tone	+\$0
<b>LU</b>	soft white	+\$0
<b>MT</b>	medium tone	+\$0
<b>WL</b>	sandstone	+\$0
<b>WN</b>	warm grey neutral	+\$0

*For formcoat® (T)*

<b>8Q</b>	folkstone grey	+\$0
<b>91</b>	white	+\$0
<b>WL</b>	sandstone	+\$0

<i>For veneer (W)</i>		
<b>ET</b>	clear on ash	+\$0
<b>EU</b>	oak on ash	+\$0
<b>EV</b>	walnut on ash	+\$0
<b>2U</b>	light brown walnut	+\$0
<b>40</b>	dark brown walnut	+\$0

Step 9. Edge Finish		
<i>For laminate top/thermoplastic edge (L)</i>		
<b>76</b>	light brown walnut	+\$0
<b>8Q</b>	folkstone grey	+\$0
<b>8Z</b>	neutral grey	+\$0
<b>91</b>	white	+\$0
<b>98</b>	studio white	+\$0
<b>BU</b>	black umber	+\$0
<b>CL</b>	cool grey neutral	+\$0
<b>HF</b>	inner tone light	+\$0
<b>HM</b>	natural maple	+\$0
<b>HP</b>	light anigre	+\$0
<b>HT</b>	inner tone	+\$0
<b>HX</b>	aged cherry	+\$0
<b>HY</b>	walnut on cherry	+\$0
<b>JB</b>	millwork cherry	+\$0
<b>LA</b>	light ash	+\$0
<b>LBA</b>	clear on ash	+\$0
<b>LBB</b>	oak on ash	+\$0
<b>LBC</b>	walnut on ash	+\$0
<b>LBD</b>	dark brown walnut	+\$0
<b>LBE</b>	medium red walnut	+\$0
<b>LBF</b>	neutral twill	+\$0
<b>LBG</b>	sarum twill	+\$0
<b>LBH</b>	earthen twill	+\$0
<b>LBJ</b>	graphite twill	+\$0
<b>LBK</b>	pewter mesh	+\$0
<b>LBL</b>	steel mesh	+\$0
<b>LBM</b>	crisp linen	+\$0
<b>LBN</b>	classic linen	+\$0
<b>LBP</b>	casual linen	+\$0
<b>LBQ</b>	white twill	+\$0
<b>LU</b>	soft white	+\$0
<b>MT</b>	medium tone	+\$0
<b>WL</b>	sandstone	+\$0
<b>WN</b>	warm grey neutral	+\$0

Step 10. Leg Finish		
<b>91</b>	white	+\$0
<b>G1</b>	graphite	+\$0
<b>MS</b>	metallic silver	+\$0
<b>47</b>	trivalent chrome	+\$150

Step 11. Bin/Bin Doors/Shelf Finish

<i>For metallic silver (MS)</i>		
<b>MS</b>	metallic silver	+\$0

<i>For graphite (G1)</i>		
<b>G1</b>	graphite	+\$0

<i>For white (91)</i>		
<b>91</b>	white	+\$0

<i>For trivalent chrome (47)</i>		
<b>91</b>	white	+\$0
<b>G1</b>	graphite	+\$0
<b>MS</b>	metallic silver	+\$0

Step 12. Bin Divider Color		
<b>MS</b>	metallic silver	+\$0
<b>G1</b>	graphite	+\$0
<b>91</b>	white	+\$0
<b>RO</b>	red	+\$30
<b>79</b>	green apple	+\$30
<b>TRQ</b>	turquoise	+\$30
<b>MY3</b>	yellow oxide	+\$30
<b>SG</b>	slate grey	+\$0

Step 13. Lock		
<i>For doors (D)</i>		
<b>KA</b>	keyed alike, black	-\$10
<b>KC</b>	keyed differently, chrome	+\$0
<b>KD</b>	keyed differently, black	+\$0
<b>KQ</b>	keyed alike, chrome	+\$0
<b>NL</b>	no lock	+\$0

Step 14. Grommet Selection		
<b>91</b>	white	+\$0
<b>G1</b>	graphite	+\$0

## Connecting Bin

BVD2.

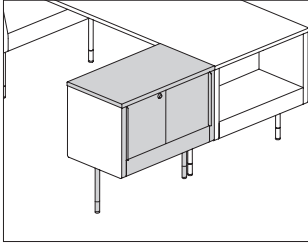

### Product Information

#### Description

Connecting bins have 2 legs and are intended to connect with desks and other connecting bins. Connecting bins have a laminate, veneer, or Formcoat® top surface with a painted steel understructure bin. They come with or without doors, and allow power pass-through. Connecting bin will support a screen when the bin does not have doors. Bin divider included. Legs have glides that provide up to 2" of adjustment.

#### Notes

Connecting bins are not freestanding and will not support screens.

All connecting bins require the use of both bin-to-bin and desktop-to-desktop ganging plates. Order desk and bin ganging plate (BVD5.C) separately.

For stability when connecting to a desk (BVD1.) or another connecting bin (BVD2.), use both desktop-to-desktop and bin-to-bin ganging plates (BVD5.C), ordered separately.

The exposed end of the connecting bin requires a desk and bin finishing kit (BVD4.), ordered separately.

Bin divider is field installed and can be specified in a complementary color.

When specifying trivalent chrome (47) leg finish, glide color is predetermined to coordinate with specified bin finish:

- Graphite (G1) bin will have black (BK) glides
- Metallic silver (MS) bin will have fog (63) glides
- White (91) bin will have folkstone grey (8Q) glides

See planning guide for more information about settings.

### Dimensions

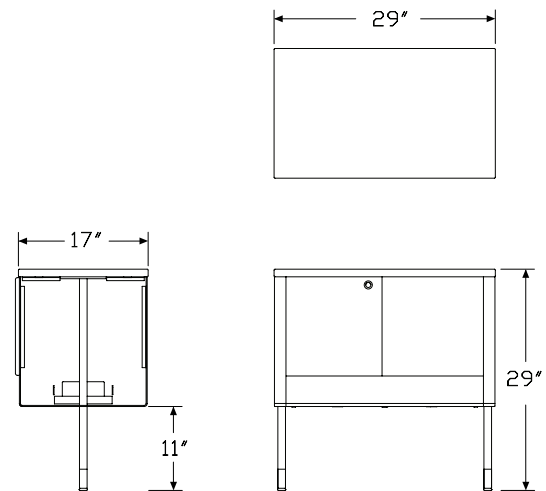

**Specification Information**

Step 1.

**BVD2.**

Step 2. Width

**29** 29" wide

Step 3. Bin Doors

**D** doors

**N** no doors

Step 4. Top Material

**L** laminate top/thermoplastic edge

**T** formcoat®

**W** veneer

Prices for Steps 1-4.

		L	T	W
<b>BVD2.</b>	<b>29 D</b>	\$1000	1050	1200
	<b>N</b>	\$857	900	1029

Step 5. Top Finish

*For laminate top/thermoplastic edge (L)*

<b>76</b>	light brown walnut	+\$0
<b>8Q</b>	folkstone grey	+\$0
<b>91</b>	white	+\$0
<b>98</b>	studio white	+\$0
<b>CL</b>	cool grey neutral	+\$0
<b>HF</b>	inner tone light	+\$0
<b>HM</b>	natural maple	+\$0
<b>HP</b>	light anigre	+\$0
<b>HT</b>	inner tone	+\$0
<b>HX</b>	aged cherry	+\$0
<b>HY</b>	walnut on cherry	+\$0
<b>LA</b>	light ash	+\$0
<b>LBA</b>	clear on ash	+\$0
<b>LBB</b>	oak on ash	+\$0
<b>LBC</b>	walnut on ash	+\$0
<b>LBD</b>	dark brown walnut	+\$0
<b>LBE</b>	medium red walnut	+\$0
<b>LBF</b>	neutral twill	+\$0
<b>LBG</b>	sarum twill	+\$0
<b>LBH</b>	earthen twill	+\$0
<b>LBJ</b>	graphite twill	+\$0
<b>LBK</b>	pewter mesh	+\$0
<b>LBL</b>	steel mesh	+\$0
<b>LBM</b>	crisp linen	+\$0
<b>LBN</b>	classic linen	+\$0
<b>LBP</b>	casual linen	+\$0
<b>LBQ</b>	white twill	+\$0
<b>LM</b>	mahogany	+\$0
<b>LT</b>	light tone	+\$0
<b>LU</b>	soft white	+\$0
<b>MT</b>	medium tone	+\$0
<b>WL</b>	sandstone	+\$0
<b>WN</b>	warm grey neutral	+\$0

*For formcoat® (T)*

<b>8Q</b>	folkstone grey	+\$0
<b>91</b>	white	+\$0
<b>WL</b>	sandstone	+\$0



*For veneer (W)*

<b>ET</b>	clear on ash	+\$0
<b>EU</b>	oak on ash	+\$0
<b>EV</b>	walnut on ash	+\$0
<b>2U</b>	light brown walnut	+\$0
<b>40</b>	dark brown walnut	+\$0

Step 6. Edge Finish

*For laminate top/thermoplastic edge (L)*

<b>76</b>	light brown walnut	+\$0
<b>8Q</b>	folkstone grey	+\$0
<b>8Z</b>	neutral grey	+\$0
<b>91</b>	white	+\$0
<b>98</b>	studio white	+\$0
<b>BU</b>	black umber	+\$0
<b>CL</b>	cool grey neutral	+\$0
<b>HF</b>	inner tone light	+\$0
<b>HM</b>	natural maple	+\$0
<b>HP</b>	light anigre	+\$0
<b>HT</b>	inner tone	+\$0
<b>HX</b>	aged cherry	+\$0
<b>HY</b>	walnut on cherry	+\$0
<b>JB</b>	millwork cherry	+\$0
<b>LA</b>	light ash	+\$0
<b>LBA</b>	clear on ash	+\$0
<b>LBB</b>	oak on ash	+\$0
<b>LBC</b>	walnut on ash	+\$0
<b>LBD</b>	dark brown walnut	+\$0
<b>LBE</b>	medium red walnut	+\$0
<b>LBF</b>	neutral twill	+\$0
<b>LBG</b>	sarum twill	+\$0
<b>LBH</b>	earthen twill	+\$0
<b>LBJ</b>	graphite twill	+\$0
<b>LBK</b>	pewter mesh	+\$0
<b>LBL</b>	steel mesh	+\$0
<b>LBM</b>	crisp linen	+\$0
<b>LBN</b>	classic linen	+\$0
<b>LBP</b>	casual linen	+\$0
<b>LBQ</b>	white twill	+\$0
<b>LU</b>	soft white	+\$0
<b>MT</b>	medium tone	+\$0
<b>WL</b>	sandstone	+\$0
<b>WN</b>	warm grey neutral	+\$0

Step 7. Leg Finish

<b>91</b>	white	+\$0
<b>G1</b>	graphite	+\$0
<b>MS</b>	metallic silver	+\$0
<b>47</b>	trivalent chrome	+\$75

Step 8. Bin/Bin Doors Finish

*For metallic silver (MS)*

<b>MS</b>	metallic silver	+\$0
-----------	-----------------	------

*For graphite (G1)*

<b>G1</b>	graphite	+\$0
-----------	----------	------

*For white (91)*

<b>91</b>	white	+\$0
-----------	-------	------

*For trivalent chrome (47)*

<b>91</b>	white	+\$0
<b>G1</b>	graphite	+\$0
<b>MS</b>	metallic silver	+\$0

Step 9. Bin Divider Color

<b>MS</b>	metallic silver	+\$0
<b>G1</b>	graphite	+\$0
<b>91</b>	white	+\$0
<b>RO</b>	red	+\$30
<b>79</b>	green apple	+\$30
<b>TRQ</b>	turquoise	+\$30
<b>MY3</b>	yellow oxide	+\$30
<b>SG</b>	slate grey	+\$0

Step 10. Lock

*For doors (D)*

<b>KA</b>	keyed alike, black	-\$10
<b>KC</b>	keyed differently, chrome	+\$0
<b>KD</b>	keyed differently, black	+\$0
<b>KQ</b>	keyed alike, chrome	+\$0
<b>NL</b>	no lock	+\$0

# Upper Bin

BVD3.

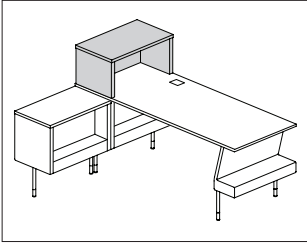

Public Office Landscape® Desking and Storage

### Product Information

**Description**  
 The upper bin sits on top of a desk, connecting bin, or freestanding bin. Upper bins have a laminate, veneer, or Formcoat® top surface with a painted steel frame.

**Notes**  
 Upper bin does not require a desk and bin finishing kit. Bin divider is field installed and can be specified in a complementary color.

### Dimensions

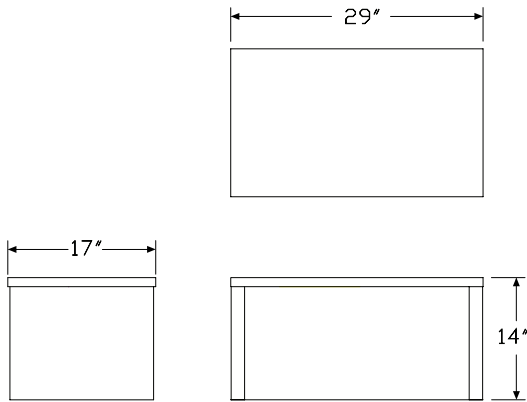

### Specification Information

**Step 1.**

**BVD3.**

**Step 2. Width**

**29** 29" wide

**Step 3. Top Material**

**L** laminate top/thermoplastic edge

**T** formcoat®

**W** veneer

Prices for Steps 1-3.

	L	T	W
<b>BVD3. 29</b>	\$661	694	794

Step 4. Top Finish

*For laminate top/thermoplastic edge (L)*

<b>76</b>	light brown walnut	+\$0
<b>8Q</b>	folkstone grey	+\$0
<b>91</b>	white	+\$0
<b>98</b>	studio white	+\$0
<b>CL</b>	cool grey neutral	+\$0
<b>HF</b>	inner tone light	+\$0
<b>HM</b>	natural maple	+\$0
<b>HP</b>	light anigre	+\$0
<b>HT</b>	inner tone	+\$0
<b>HX</b>	aged cherry	+\$0
<b>HY</b>	walnut on cherry	+\$0
<b>LA</b>	light ash	+\$0
<b>LBA</b>	clear on ash	+\$0
<b>LBB</b>	oak on ash	+\$0
<b>LBC</b>	walnut on ash	+\$0
<b>LBD</b>	dark brown walnut	+\$0
<b>LBE</b>	medium red walnut	+\$0
<b>LBF</b>	neutral twill	+\$0
<b>LBG</b>	sarum twill	+\$0
<b>LBH</b>	earthen twill	+\$0
<b>LBJ</b>	graphite twill	+\$0
<b>LBK</b>	pewter mesh	+\$0
<b>LBL</b>	steel mesh	+\$0
<b>LBM</b>	crisp linen	+\$0
<b>LBN</b>	classic linen	+\$0
<b>LBP</b>	casual linen	+\$0
<b>LBQ</b>	white twill	+\$0
<b>LM</b>	mahogany	+\$0
<b>LT</b>	light tone	+\$0
<b>LU</b>	soft white	+\$0
<b>MT</b>	medium tone	+\$0
<b>WL</b>	sandstone	+\$0
<b>WN</b>	warm grey neutral	+\$0

*For formcoat® (T)*

<b>91</b>	white	+\$0
<b>8Q</b>	folkstone grey	+\$0
<b>WL</b>	sandstone	+\$0

*For veneer (W)*

<b>ET</b>	clear on ash	+\$0
<b>EU</b>	oak on ash	+\$0
<b>EV</b>	walnut on ash	+\$0
<b>2U</b>	light brown walnut	+\$0
<b>40</b>	dark brown walnut	+\$0

Step 5. Edge Finish

*For laminate top/thermoplastic edge (L)*

<b>76</b>	light brown walnut	+\$0
<b>8Q</b>	folkstone grey	+\$0
<b>8Z</b>	neutral grey	+\$0
<b>91</b>	white	+\$0
<b>98</b>	studio white	+\$0
<b>BU</b>	black umber	+\$0
<b>CL</b>	cool grey neutral	+\$0
<b>HF</b>	inner tone light	+\$0
<b>HM</b>	natural maple	+\$0
<b>HP</b>	light anigre	+\$0
<b>HT</b>	inner tone	+\$0
<b>HX</b>	aged cherry	+\$0
<b>HY</b>	walnut on cherry	+\$0
<b>JB</b>	millwork cherry	+\$0
<b>LA</b>	light ash	+\$0
<b>LBA</b>	clear on ash	+\$0
<b>LBB</b>	oak on ash	+\$0
<b>LBC</b>	walnut on ash	+\$0
<b>LBD</b>	dark brown walnut	+\$0
<b>LBE</b>	medium red walnut	+\$0
<b>LBF</b>	neutral twill	+\$0
<b>LBG</b>	sarum twill	+\$0
<b>LBH</b>	earthen twill	+\$0
<b>LBJ</b>	graphite twill	+\$0
<b>LBK</b>	pewter mesh	+\$0
<b>LBL</b>	steel mesh	+\$0
<b>LBM</b>	crisp linen	+\$0
<b>LBN</b>	classic linen	+\$0
<b>LBP</b>	casual linen	+\$0
<b>LBQ</b>	white twill	+\$0
<b>LU</b>	soft white	+\$0
<b>MT</b>	medium tone	+\$0
<b>WL</b>	sandstone	+\$0
<b>WN</b>	warm grey neutral	+\$0

## Upper Bin *continued*

Step 6. Bin Finish		
<b>MS</b>	metallic silver	+\$0
<b>G1</b>	graphite	+\$0
<b>91</b>	white	+\$0

Step 7. Bin Divider Color		
<b>MS</b>	metallic silver	+\$0
<b>G1</b>	graphite	+\$0
<b>91</b>	white	+\$0
<b>RO</b>	red	+\$30
<b>79</b>	green apple	+\$30
<b>TRQ</b>	turquoise	+\$30
<b>MY3</b>	yellow oxide	+\$30
<b>SG</b>	slate grey	+\$0

# Freestanding Bin

BVB1.

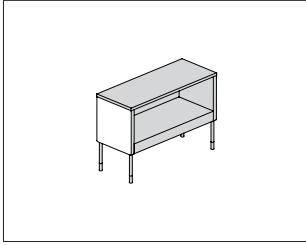

### Product Information

#### Description

This freestanding bin has 4 legs and provides shared storage. It has a laminate, veneer, or Formcoat® work surface with a painted steel understructure bin. It is available with or without power access, with or without doors, and accepts screen attachment. Legs have glides that provide up to 2" of adjustment. Bin divider included.

#### Notes

The exposed end of the understructure bin requires a desk and bin finishing kit (BVD4.), ordered separately.

To connect to other freestanding bins, order desk and bin ganging plate (BVD5.) separately.

Freestanding bins do not allow power pass-through, but can be ordered with grommets to accommodate power at the top surface.

To bring power to the surface of a freestanding bin with power access, order Logic Mini, Grommet Mount (Y1414.) separately.

Bin divider can be specified in a complementary color.

Grommet color is either graphite or white, matched to the work surface color.

When specifying trivalent chrome (47) leg finish, glide color is predetermined to coordinate with specified bin finish:

- Graphite (G1) bin will have black (BK) glides
- Metallic silver (MS) bin will have fog (63) glides
- White (G1) bin will have folkstone grey (8Q) glides

#### Dimensions

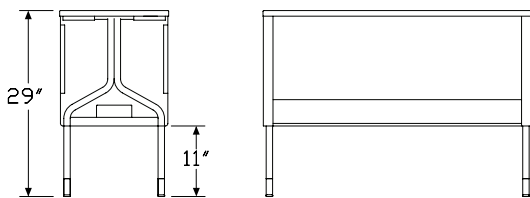
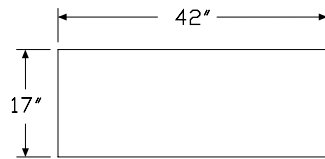

### Specification Information

#### Step 1.

**BVB1.**

#### Step 2. Width

- 29** 29" wide
- 42** 42" wide

#### Step 3. Power Access

- P** power access
- N** no power access

#### Step 4. Bin Doors

- D** doors
- N** no doors

#### Step 5. Top Material

- L** laminate top/thermoplastic edge
- T** formcoat®
- W** veneer

#### Prices for Steps 1-5.

		DL	DT	DW	NL	NT	NW
<b>BVB1.</b>	<b>29 P</b>	\$1086	1140	1303	943	990	1131
	<b>N</b>	\$1000	1050	1200	857	900	1029
	<b>42 P</b>	\$1229	1290	1474	1086	1140	1303
	<b>N</b>	\$1143	1200	1371	1000	1050	1200

# Freestanding Bin *continued*

## Step 6. Top Finish

### For laminate top/thermoplastic edge (L)

<b>76</b>	light brown walnut	+\$0
<b>8Q</b>	folkstone grey	+\$0
<b>91</b>	white	+\$0
<b>98</b>	studio white	+\$0
<b>CL</b>	cool grey neutral	+\$0
<b>HF</b>	inner tone light	+\$0
<b>HM</b>	natural maple	+\$0
<b>HP</b>	light anigre	+\$0
<b>HT</b>	inner tone	+\$0
<b>HX</b>	aged cherry	+\$0
<b>HY</b>	walnut on cherry	+\$0
<b>LA</b>	light ash	+\$0
<b>LBA</b>	clear on ash	+\$0
<b>LBB</b>	oak on ash	+\$0
<b>LBC</b>	walnut on ash	+\$0
<b>LBD</b>	dark brown walnut	+\$0
<b>LBE</b>	medium red walnut	+\$0
<b>LBF</b>	neutral twill	+\$0
<b>LBG</b>	sarum twill	+\$0
<b>LBH</b>	earthen twill	+\$0
<b>LBJ</b>	graphite twill	+\$0
<b>LBK</b>	pewter mesh	+\$0
<b>LBL</b>	steel mesh	+\$0
<b>LBM</b>	crisp linen	+\$0
<b>LBN</b>	classic linen	+\$0
<b>LBP</b>	casual linen	+\$0
<b>LBQ</b>	white twill	+\$0
<b>LM</b>	mahogany	+\$0
<b>LT</b>	light tone	+\$0
<b>LU</b>	soft white	+\$0
<b>MT</b>	medium tone	+\$0
<b>WL</b>	sandstone	+\$0
<b>WN</b>	warm grey neutral	+\$0

### For formcoat® (T)

<b>91</b>	white	+\$0
<b>8Q</b>	folkstone grey	+\$0
<b>WL</b>	sandstone	+\$0

## For veneer (W)

<b>ET</b>	clear on ash	+\$0
<b>EU</b>	oak on ash	+\$0
<b>EV</b>	walnut on ash	+\$0
<b>2U</b>	light brown walnut	+\$0
<b>40</b>	dark brown walnut	+\$0

## Step 7. Edge Finish

### For laminate top/thermoplastic edge (L)

<b>76</b>	light brown walnut	+\$0
<b>8Q</b>	folkstone grey	+\$0
<b>8Z</b>	neutral grey	+\$0
<b>91</b>	white	+\$0
<b>98</b>	studio white	+\$0
<b>BU</b>	black umber	+\$0
<b>CL</b>	cool grey neutral	+\$0
<b>HF</b>	inner tone light	+\$0
<b>HM</b>	natural maple	+\$0
<b>HP</b>	light anigre	+\$0
<b>HT</b>	inner tone	+\$0
<b>HX</b>	aged cherry	+\$0
<b>HY</b>	walnut on cherry	+\$0
<b>JB</b>	millwork cherry	+\$0
<b>LA</b>	light ash	+\$0
<b>LBA</b>	clear on ash	+\$0
<b>LBB</b>	oak on ash	+\$0
<b>LBC</b>	walnut on ash	+\$0
<b>LBD</b>	dark brown walnut	+\$0
<b>LBE</b>	medium red walnut	+\$0
<b>LBF</b>	neutral twill	+\$0
<b>LBG</b>	sarum twill	+\$0
<b>LBH</b>	earthen twill	+\$0
<b>LBJ</b>	graphite twill	+\$0
<b>LBK</b>	pewter mesh	+\$0
<b>LBL</b>	steel mesh	+\$0
<b>LBM</b>	crisp linen	+\$0
<b>LBN</b>	classic linen	+\$0
<b>LBP</b>	casual linen	+\$0
<b>LBQ</b>	white twill	+\$0
<b>LU</b>	soft white	+\$0
<b>MT</b>	medium tone	+\$0
<b>WL</b>	sandstone	+\$0
<b>WN</b>	warm grey neutral	+\$0

## Freestanding Bin *continued*

Step 8. Leg Finish		
<b>91</b>	white	+\$0
<b>G1</b>	graphite	+\$0
<b>MS</b>	metallic silver	+\$0
<b>47</b>	trivalent chrome	+\$150

Step 9. Bin/Bin Doors Finish		
------------------------------	--	--

<i>For metallic silver (MS)</i>		
<b>MS</b>	metallic silver	+\$0

<i>For graphite (G1)</i>		
<b>G1</b>	graphite	+\$0

<i>For white (91)</i>		
<b>91</b>	white	+\$0

<i>For trivalent chrome (47)</i>		
<b>91</b>	white	+\$0
<b>G1</b>	graphite	+\$0
<b>MS</b>	metallic silver	+\$0

Step 10. Bin Divider Color		
<b>MS</b>	metallic silver	+\$0
<b>G1</b>	graphite	+\$0
<b>91</b>	white	+\$0
<b>RO</b>	red	+\$30
<b>79</b>	green apple	+\$30
<b>TRQ</b>	turquoise	+\$30
<b>MY3</b>	yellow oxide	+\$30
<b>SG</b>	slate grey	+\$0

Step 11. Lock		
<i>For doors (D)</i>		
<b>KA</b>	keyed alike, black	-\$10
<b>KC</b>	keyed differently, chrome	+\$0
<b>KD</b>	keyed differently, black	+\$0
<b>KQ</b>	keyed alike, chrome	+\$0
<b>NL</b>	no lock	+\$0

Step 12. Grommet Selection		
<i>For power access (P)</i>		
<b>91</b>	white	+\$0
<b>G1</b>	graphite	+\$0

# Half Bin

BVB2.

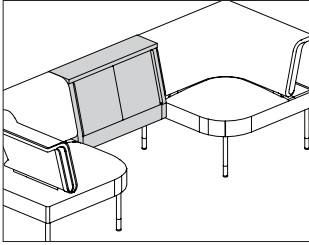

Public Office Landscape® Desking and Storage

### Product Information

#### Description

This bin creates a bridge in group settings that include sectional seating and screens. It has a laminate, veneer, or Formcoat® top surface with a painted steel bin. It comes with doors, and accepts screen attachment. Legs have glides that provide up to 2" of adjustment. Ganging hardware included.

#### Notes

Half bin must be attached to 2 chairs.

When specifying trivalent chrome (47) leg finish, glide color is predetermined to coordinate with specified bin finish:

- Graphite (G1) bin will have black (BK) glides
- Metallic silver (MS) bin will have fog (63) glides
- White (91) bin will have folkstone grey (8Q) glides

#### Dimensions

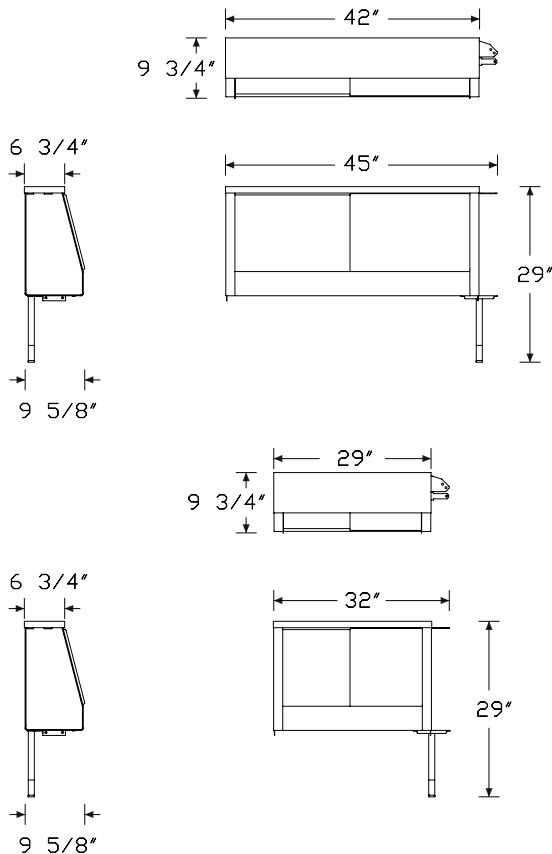

### Specification Information

#### Step 1.

**BVB2.**

#### Step 2. Width

- 29** 29" wide
- 42** 42" wide

#### Step 3. Bin Doors

**D** doors

#### Step 4. Leg Option

- N** bin without legs
- L** bin with one shared leg

#### Step 5. Top Material

- L** laminate top/thermoplastic edge
- T** formcoat®
- W** veneer

#### Prices for Steps 1-5.

		NL	NT	NW	LL	LT	LW
<b>BVB2.</b>	<b>29 D</b>	\$857	900	1029	914	960	1097
	<b>42 D</b>	\$971	1020	1166	1028	1080	1234



Step 6. Top Finish

*For laminate top/thermoplastic edge (L)*

<b>76</b>	light brown walnut	+\$0
<b>8Q</b>	folkstone grey	+\$0
<b>91</b>	white	+\$0
<b>98</b>	studio white	+\$0
<b>CL</b>	cool grey neutral	+\$0
<b>HF</b>	inner tone light	+\$0
<b>HM</b>	natural maple	+\$0
<b>HP</b>	light anigre	+\$0
<b>HT</b>	inner tone	+\$0
<b>HX</b>	aged cherry	+\$0
<b>HY</b>	walnut on cherry	+\$0
<b>LA</b>	light ash	+\$0
<b>LBA</b>	clear on ash	+\$0
<b>LBB</b>	oak on ash	+\$0
<b>LBC</b>	walnut on ash	+\$0
<b>LBD</b>	dark brown walnut	+\$0
<b>LBE</b>	medium red walnut	+\$0
<b>LBF</b>	neutral twill	+\$0
<b>LBG</b>	sarum twill	+\$0
<b>LBH</b>	earthen twill	+\$0
<b>LBJ</b>	graphite twill	+\$0
<b>LBK</b>	pewter mesh	+\$0
<b>LBL</b>	steel mesh	+\$0
<b>LBM</b>	crisp linen	+\$0
<b>LBN</b>	classic linen	+\$0
<b>LBP</b>	casual linen	+\$0
<b>LBQ</b>	white twill	+\$0
<b>LM</b>	mahogany	+\$0
<b>LT</b>	light tone	+\$0
<b>LU</b>	soft white	+\$0
<b>MT</b>	medium tone	+\$0
<b>WL</b>	sandstone	+\$0
<b>WN</b>	warm grey neutral	+\$0

*For formcoat® (T)*

<b>91</b>	white	+\$0
<b>8Q</b>	folkstone grey	+\$0
<b>WL</b>	sandstone	+\$0

*For veneer (W)*

<b>ET</b>	clear on ash	+\$0
<b>EU</b>	oak on ash	+\$0
<b>EV</b>	walnut on ash	+\$0
<b>2U</b>	light brown walnut	+\$0
<b>40</b>	dark brown walnut	+\$0

Step 7. Edge Finish

*For laminate top/thermoplastic edge (L)*

<b>76</b>	light brown walnut	+\$0
<b>8Q</b>	folkstone grey	+\$0
<b>8Z</b>	neutral grey	+\$0
<b>91</b>	white	+\$0
<b>98</b>	studio white	+\$0
<b>BU</b>	black umber	+\$0
<b>CL</b>	cool grey neutral	+\$0
<b>HF</b>	inner tone light	+\$0
<b>HM</b>	natural maple	+\$0
<b>HP</b>	light anigre	+\$0
<b>HT</b>	inner tone	+\$0
<b>HX</b>	aged cherry	+\$0
<b>HY</b>	walnut on cherry	+\$0
<b>JB</b>	millwork cherry	+\$0
<b>LA</b>	light ash	+\$0
<b>LBA</b>	clear on ash	+\$0
<b>LBB</b>	oak on ash	+\$0
<b>LBC</b>	walnut on ash	+\$0
<b>LBD</b>	dark brown walnut	+\$0
<b>LBE</b>	medium red walnut	+\$0
<b>LBF</b>	neutral twill	+\$0
<b>LBG</b>	sarum twill	+\$0
<b>LBH</b>	earthen twill	+\$0
<b>LBJ</b>	graphite twill	+\$0
<b>LBK</b>	pewter mesh	+\$0
<b>LBL</b>	steel mesh	+\$0
<b>LBM</b>	crisp linen	+\$0
<b>LBN</b>	classic linen	+\$0
<b>LBP</b>	casual linen	+\$0
<b>LBQ</b>	white twill	+\$0
<b>LU</b>	soft white	+\$0
<b>MT</b>	medium tone	+\$0
<b>WL</b>	sandstone	+\$0
<b>WN</b>	warm grey neutral	+\$0

# Half Bin *continued*

## Step 8. Leg Finish

### *For bin with one shared leg (L)*

<b>91</b>	white	+\$0
<b>G1</b>	graphite	+\$0
<b>MS</b>	metallic silver	+\$0
<b>47</b>	trivalent chrome	+\$15

### *For bin without legs (N)*

<b>N</b>	none	+\$0
----------	------	------

## Step 9. Bin/Bin Doors Finish

### *For metallic silver (MS)*

<b>MS</b>	metallic silver	+\$0
-----------	-----------------	------

### *For graphite (G1)*

<b>G1</b>	graphite	+\$0
-----------	----------	------

### *For white (91)*

<b>91</b>	white	+\$0
-----------	-------	------

### *For none (N) or trivalent chrome (47)*

<b>91</b>	white	+\$0
<b>G1</b>	graphite	+\$0
<b>MS</b>	metallic silver	+\$0

## Step 10. Bin Divider Color

		<b>29</b>	<b>42</b>
<b>MS</b>	metallic silver	+\$0	0
<b>G1</b>	graphite	+\$0	0
<b>91</b>	white	+\$0	0
<b>RO</b>	red	+\$30	45
<b>79</b>	green apple	+\$30	45
<b>TRQ</b>	turquoise	+\$30	45
<b>MY3</b>	yellow oxide	+\$30	45
<b>SG</b>	slate grey	+\$0	0

# Desk and Bin Finishing Kit

BVD4.

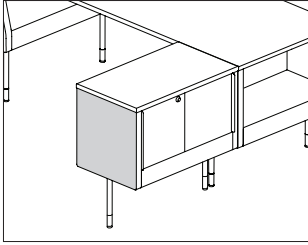

### Product Information

#### Description

This finishing kit is painted steel and covers the exposed end of a desk, peninsula table, connecting bin, or freestanding bin.

#### Notes

Specify kit color to match color of corresponding desk, peninsula table, connecting bin, or freestanding bin.

#### Dimensions

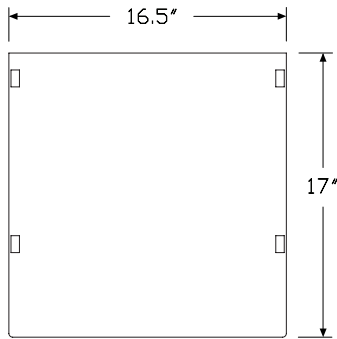

### Specification Information

#### Step 1.

**BVD4.**

#### Step 2. Kit Application

- 1 bin finishing kit, single
- 2 bin finishing kit, double

#### Prices for Steps 1-2.

<b>BVD4. 1</b>	\$49
<b>2</b>	\$85

#### Step 3. End Cap Material Finish

<b>G1</b>	graphite	+\$0
<b>91</b>	white	+\$0
<b>MS</b>	metallic silver	+\$0

# Desk and Bin Ganging Plate

BVD5.

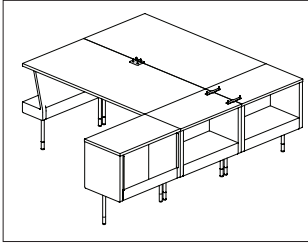

## Product Information

### Description

These ganging plates provide attachment between bins, desks, and peninsula tables. Attachment hardware included.

### Notes

Desk (BVD1.) requires ganging plates (BVD5.C) to attach to other desks or connecting bins.

Connecting bin (BVD2.) requires ganging plates (BVD5.C) to attach to other connecting bins or desks.

Peninsula table (BVT4.) requires ganging plates (BVD5.B) to attach to freestanding bins.

Freestanding bin (BVB1.) requires ganging plates (BVD5.B) to attach to peninsula table or other freestanding bins.

See Planning Guide for more information about settings.

Public Office Landscape® Desking and Storage

## Dimensions

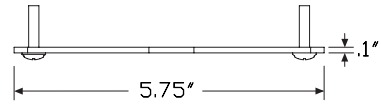

Peninsula table & freestanding bin ganging plates (B)

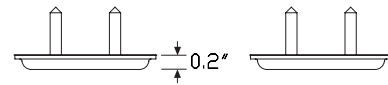
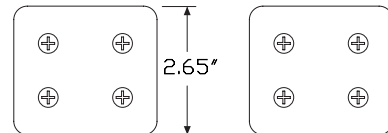
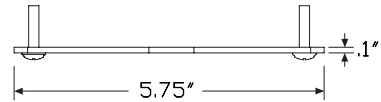

Desk & connecting bin ganging plates (C)

# Desk and Bin Ganging Plate

*continued*

## Specification Information

Step 1.

**BVD5.**

Step 2. Application

**B** bin-to-bin

**C** connecting bin ganging kit

Prices for Steps 1-2.

<b>BVD5. B</b>	\$63
<b>C</b>	\$126

# Modular Power Entry

BVE01.

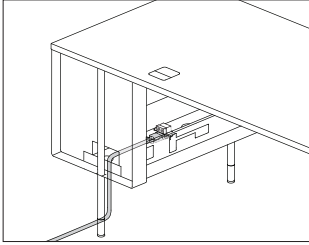

Public Office Landscape® Power

## Product Information

**Description**  
 This power entry connects a buildings electrical supply from a wall, floor, or column to a desk or connecting bin. It enters through the bottom of the desk or bin. The power entry plugs into any of the ports on the power block and includes a cable that can be field cut to the appropriate length. Cord comes in 6', 10', and 20' lengths. UL listed and Canadian UL listed.

**Notes**  
 A licensed electrician must wire power entry.

## Dimensions

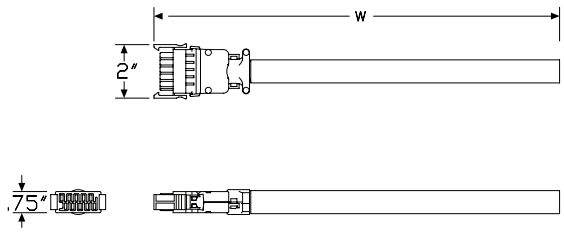

## Specification Information

**Step 1.**

**BVE01.**

### Step 2. Wire Configuration

**08** 8 wire

### Step 3. Cord Length

**06** 6' long

**10** 10' long

**20** 20' long

### Prices for Steps 1-3.

	06	10	20
<b>BVE01. 08</b>	\$186	259	360

Modular Power Entry, New York BVE02.

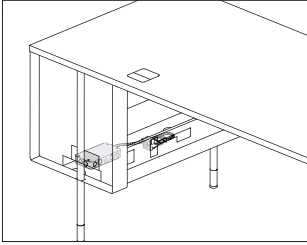

**Product Information**

**Description**

This power entry connects a buildings electrical supply from a wall, floor, or column to a desk or connecting bin. It includes a junction box with 8" of wire and a harness. The junction box can be located in the desk or connecting bin. The power entry plugs into any of the ports on the power block. UL listed and Canadian UL listed.

**Notes**

A licensed electrician must wire power entry.

**Dimensions**

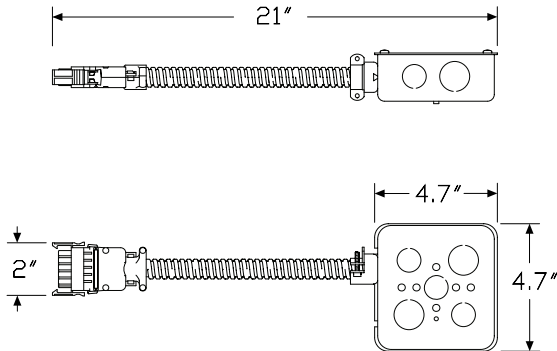

**Specification Information**

Step 1.

**BVE02.**

Step 2. Wire Configuration

**08** 8 wire

Prices for Steps 1-2.

**BVE02. 08**

\$243

# Power Block

BVE03.

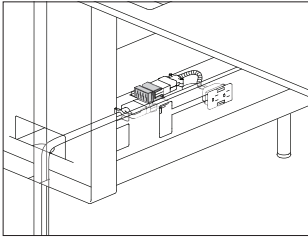

## Product Information

### Description

This power block has electrical ports for connecting modular power to receptacles and jumpers. It can be located in a desk, preinstalled into the connecting bin, and for power bridge access desk applications can be located in the L-shelf bin. UL listed and Canadian UL listed.

### Notes

When using the power bridge desk (BVD1.xxxxB) to power a café table, order the 4 port with receptacle harness (4R) configuration to be installed underneath the L-shelf.

When connecting modular power within connecting bins and desk bins, order the 4 port (04) configuration.

When using the power bridge desk (BVD1.xxxxB) to bring power across desks without a café table configuration between the desks, order the 4 port (04) configuration.

See Planning Guide for more information about power.

## Dimensions

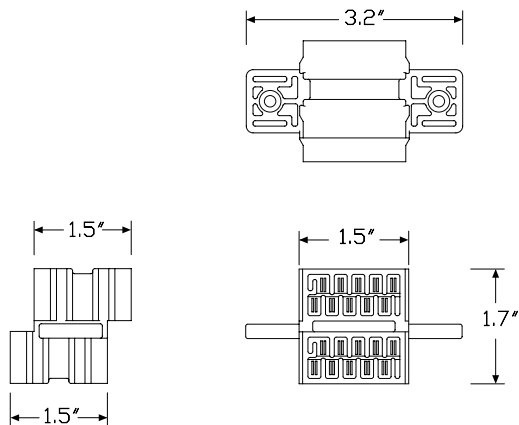

## Specification Information

### Step 1.

**BVE03.**

### Step 2. Wire Configuration

**08** 8 wire

### Step 3. Block Configuration

**04** 4 port

**4R** 4 port with receptacle harness A

### Prices for Steps 1-3.

	<b>04</b>	<b>4R</b>
<b>BVE03. 08</b>	\$43	80



# Modular Power Duplex

BVE04.

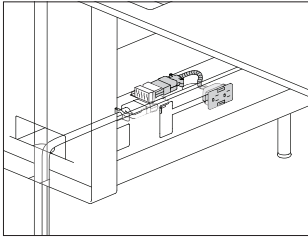

### Product Information

#### Description

This receptacle connects to a power block and provides power to a desk. Package contains 1 duplex receptacle. UL listed and Canadian UL listed.

#### Notes

When using the power bridge desk (BVD1.xxxxB) to power a café table, order the 8 wire duplex receptacle (FW152) separately.

#### Dimensions

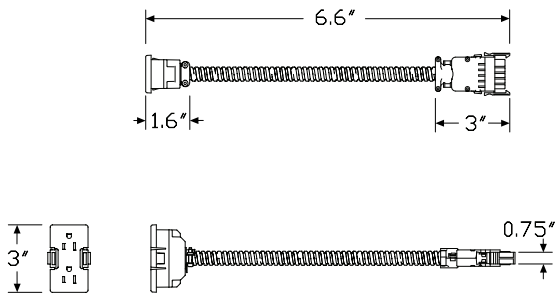

### Specification Information

#### Step 1.

**BVE04.**

#### Step 2. Wire Configuration

**08** 8 wire

#### Step 3. Duplex Type

- AN** circuit a - shared neutral, 8 wire
- BN** circuit b - shared neutral, 8 wire
- CN** circuit c - shared neutral, 8 wire
- DN** circuit d - shared neutral, 8 wire
- AG** circuit a - shared neutral isolated ground, 8 wire
- BG** circuit b - shared neutral isolated ground, 8 wire
- CG** circuit c - shared neutral isolated ground, 8 wire
- DG** circuit d - shared neutral isolated ground, 8 wire

#### Prices for Steps 1-3.

	<b>AN</b>	<b>BN</b>	<b>CN</b>	<b>DN</b>	<b>AG</b>	<b>BG</b>	<b>CG</b>	<b>DG</b>
<b>BVE04. 08</b>	\$100	100	100	100	100	100		
<b>BVE04. 08</b>							\$100	100

#### Step 4. Duplex Color

- 91** white +\$0
- BK** black +\$0

# Modular Power Controlled Duplex BVE04M

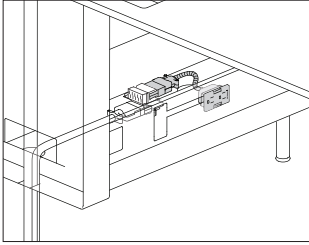

## Product Information

### Description

This receptacle is to be used for ASHRAE90.1 and Title 24 compliance. A controlled receptacle should be used for any receptacles that are under automated control by the energy management system. The receptacle connects to a power block and provides power to a desk. Package contains 1 duplex receptacle. It is UL listed and Canadian UL listed.

### Dimensions

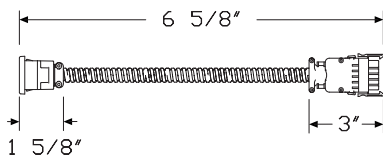

## Specification Information

### Step 1.

**BVE04M.**

### Step 2. Wire Configuration

**08** 8 wire

### Step 3. Duplex Type

- AN** circuit a - shared neutral, 8 wire
- BN** circuit b - shared neutral, 8 wire
- CN** circuit c - shared neutral, 8 wire
- DN** circuit d - shared neutral, 8 wire
- AG** circuit a - shared neutral isolated ground, 8 wire
- BG** circuit b - shared neutral isolated ground, 8 wire
- CG** circuit c - shared neutral isolated ground, 8 wire
- DG** circuit d - shared neutral isolated ground, 8 wire

### Prices for Steps 1-3.

	<b>AN</b>	<b>BN</b>	<b>CN</b>	<b>DN</b>	<b>AG</b>	<b>BG</b>
<b>BVE04M. 08</b>	\$100	100	100	100	100	100
					<b>CG</b>	<b>DG</b>
<b>BVE04M. 08</b>					\$100	100

### Step 4. Duplex Color

- 91** white +\$0
- BK** black +\$0

# Power Block-to-Power Block Jumper

BVE05.

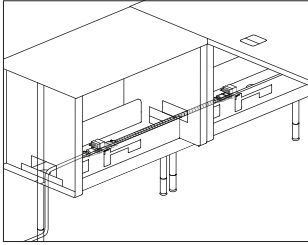

### Product Information

#### Description

This power jumper connects power block to power block in desks and connecting bins. UL listed and Canadian UL listed.

#### Notes

The 29" jumper distributes power through adjacent desk bin and connecting bin raceways. It connects power blocks in desk back-to-back and offset back-to-back configurations with side-to-side desk bins.

The 52" jumper distributes power through back-to-back desk bin or connecting bin raceways. This jumper includes cover to house jumper outside of the bin.

The 116" jumper distributes power between the power bridge desk (BVD1.xxxxB) in applications where the social chair and/or café table configuration is used in conjunction with the desk.

The 134" jumper distributes power underneath the desk surface of the power bridge desk (BVD1.xxxxB).

See Planning Guide for more information about settings.

### Dimensions

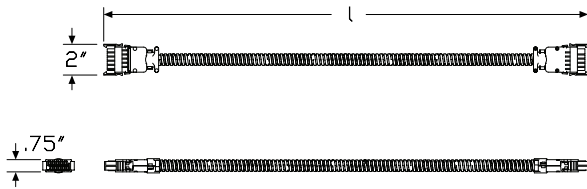

### Specification Information

#### Step 1.

**BVE05.**

#### Step 2. Wire Configuration

**08** 8 wire

#### Step 3. Jumper Length

**29** 29" wide

**30** 52" wide

**116** 116" wide

**134** 134" wide

#### Prices for Steps 1-3.

	<b>29</b>	<b>30</b>	<b>116</b>	<b>134</b>
<b>BVE05. 08</b>	\$100	150	160	180

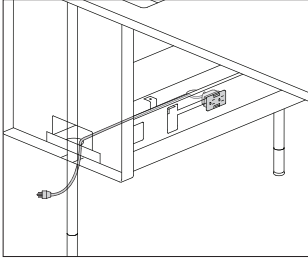

**Product Information**

**Description**

This corded power receptacle provides a plug-in solution in lieu of the modular power system. It plugs directly into a wall or floor outlet. Cord comes in 6', 10', and 20' lengths. Package contains 1 duplex receptacle. UL listed and Canadian UL listed.

**Dimensions**

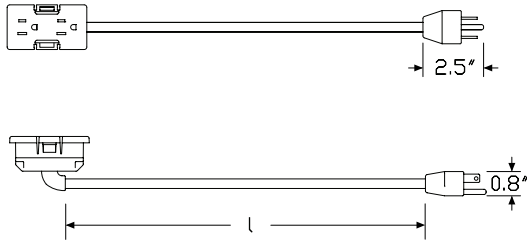

Public Office Landscape® Power

**Specification Information**

**Step 1.**

**BVE06.**

**Step 2. Duplex Configuration**

**1** single duplex

**Step 3. Cord Length**

- 06** 6' long
- 10** 10' long
- 20** 20' long

**Prices for Steps 1-3.**

	<b>06</b>	<b>10</b>	<b>20</b>
<b>BVE06. 1</b>	\$91	109	166

**Step 4. Duplex Color**

<b>91</b>	white		+\$0
<b>BK</b>	black		+\$0

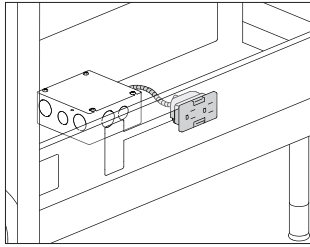

**Product Information**

**Description**

This hardwired receptacle connects to the Chicago Power Junction Box and provides power to the desk. Package contains 1 duplex receptacle. UL listed and Canadian UL listed.

**Notes**

A licensed electrician must wire the receptacle to the junction box (BVEo8.), ordered separately.

**Dimensions**

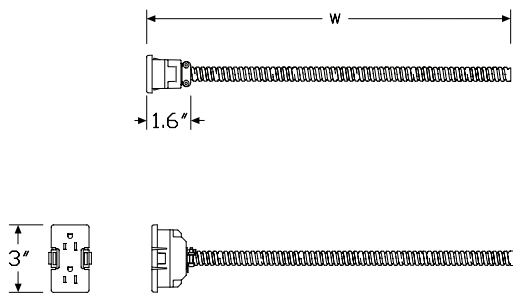

**Specification Information**

**Step 1.**

**BVE07.**

**Step 2. Configuration**

- A** circuit a
- B** circuit b

**Prices for Steps 1-2.**

<b>BVE07. A</b>	\$100
<b>B</b>	\$100

**Step 3. Duplex Color**

<b>91</b> white	+\$0
<b>BK</b> black	+\$0

# Chicago Power - Controlled Duplex

BVE07M

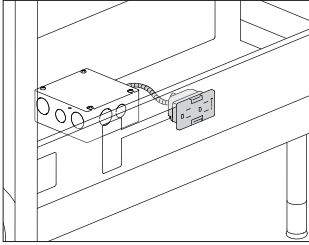

Public Office Landscape® Power

## Product Information

### Description

This receptacle is to be used for ASHRAE90.1 and Title 24 compliance. A controlled receptacle should be used for any receptacles that are under automated control by the energy management system. This hard-wired receptacle connects to the Chicago power junction box and provides power to a desk. Package contains 1 duplex receptacle. It is UL listed and Canadian UL listed.

### Notes

A licensed electrician must wire the receptacle to the junction box (BVEo8.), ordered separately.

### Dimensions

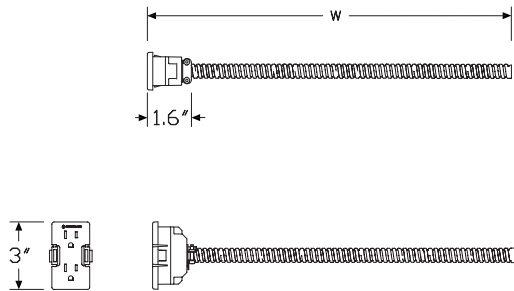

## Specification Information

### Step 1.

**BVE07M.**  A

### Step 2. Configuration

**A** circuit a  A

**B** circuit b  A

### Prices for Steps 1-2.

<b>BVE07M. A</b>	\$100
<b>B</b>	\$100

### Step 3. Duplex Color

<b>91</b> white <input type="checkbox"/> A	+ \$0
<b>BK</b> black <input type="checkbox"/> A	+ \$0

Controlled Receptacle Decal  
(12 per sheet)

G9999.

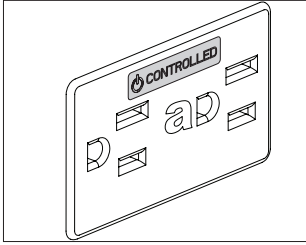

**Product Information**

**Description**

This decal is to be used for ASHRAE90.1 and Title 24 compliance. The decal is used to mark standard receptacles (new or existing) that are under automated control by the energy management system. 1 sheet includes 12 clear decals with white or black print.

**Dimensions**

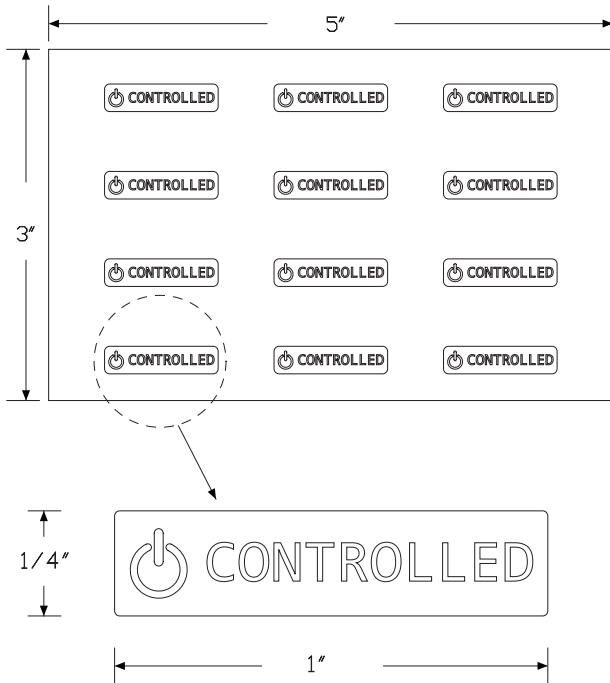

**Specification Information**

**Step 1.**

**G9999.**  A

**Step 2. Color**

**B** black print  A

**W** white print  A

**Prices for Steps 1-2.**

<b>G9999. B</b>	\$8
<b>W</b>	\$8

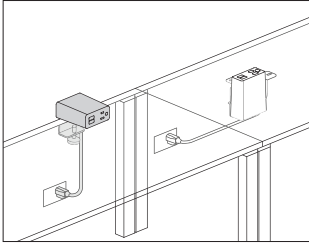

**Product Information**

**Description**

This electrical distributor plugs directly into floor, wall, or ceiling drop outlets. Each module configuration presents the same visual appearance. Cable clips and attachment hardware included. Product is UL listed.

**Notes**

Cable clips for cord management are intended for a 1-time installation. Clamp versions can be reoriented in the field by a technician. A small LED light illuminates through the USB ports when the USB version is plugged in and powered. USB ports provide 10-watt power to charge most devices and tablets at full speed. Cord color is predetermined. For white (G1) finish cords will be white. For graphite (G1) finish cords will be black. Grommet mount attachment (Y1414.xxxG) does not come with the mini grommet. Order Logic mini grommet (Y1412.) separately, as needed.

Public Office Landscape® Power

**Dimensions**

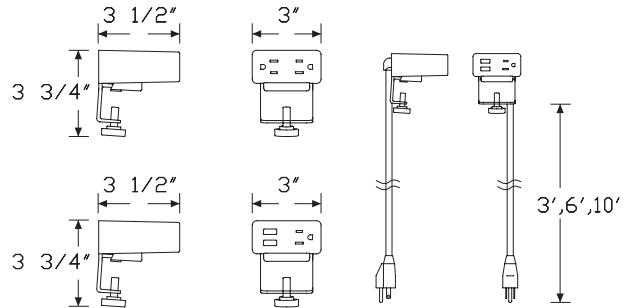

**Surface Clamp**

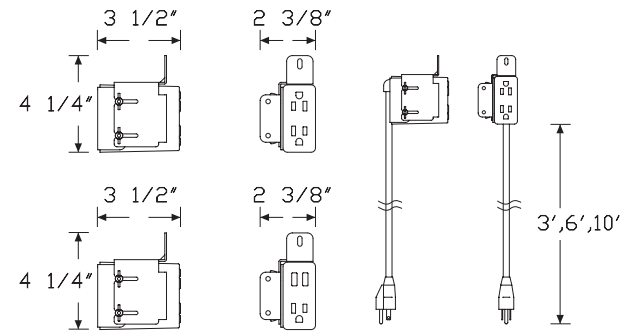

**Grommet Mount**



**Specification Information**

Step 1.

**Y1414.**  A

Step 2. Configuration

**J** 1 simplex receptacles, 2 powered USB  A

**K** 2 simplex receptacles  A

Step 3. Cord/Conduit Length

**03** 3' cord/conduit  A

**06** 6' cord/conduit  A

**10** 10' cord/conduit  A

Step 4. Attachment

**G** grommet mount  A

**S** surface clamp  A

Prices for Steps 1-4.

		<b>G</b>	<b>S</b>
<b>Y1414. J</b>	<b>03</b>	\$342	342
	<b>06</b>	\$342	342
	<b>10</b>	\$352	352
	<b>K 03</b>	\$191	191
	<b>06</b>	\$191	191
	<b>10</b>	\$201	201

Step 5. Finish

**91** white  A + \$0

**G1** graphite  A + \$0

Logic G1200 Grommet Pass Thru Y1420.

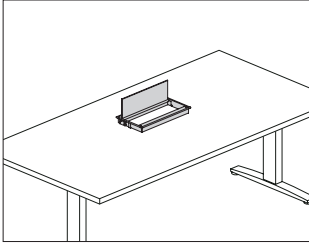

**Product Information**

**Description**  
 This Logic Power Access Solutions™ grommet mounted metal enclosure provides access to cords kept beneath the surface. The unit has an integrated cord keeper.

**Notes**

Unit size is based on the grommet mounted electrical distributor (Y1425.) with simplex receptacles.

**Dimensions**

Public Office Landscape® Power

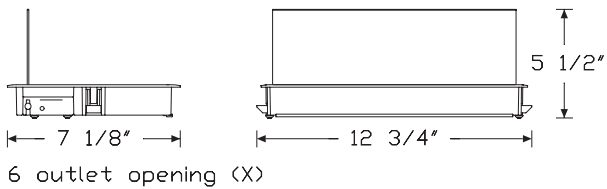
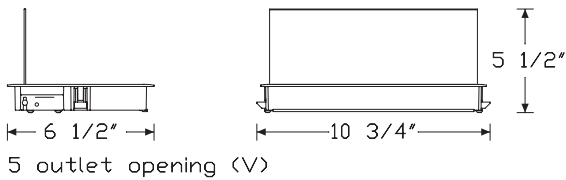
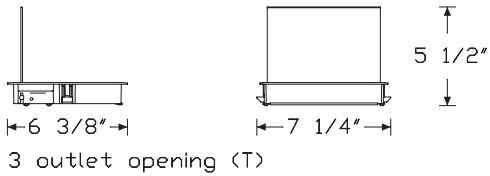

**Specification Information**

**Step 1.**

**Y1420.**  A

**Step 2. Configuration**

- T** three outlet opening  A
- V** five outlet opening  A
- X** six outlet opening  A

**Prices for Steps 1-2.**

<b>Y1420. T</b>	\$220
<b>V</b>	\$242
<b>X</b>	\$263

**Step 3. Finish**

<b>91</b> white <input type="checkbox"/> A	+\$0
<b>G1</b> graphite <input type="checkbox"/> A	+\$0
<b>MS</b> metallic silver <input type="checkbox"/> A	+\$0

# Chicago Power - Junction Box

BVE08.

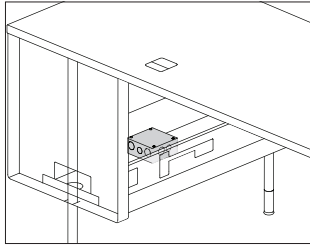

## Product Information

### Description

This hardwired junction box provides power for up to 2 hardwired Chicago Power Receptacles. UL listed and Canadian UL listed.

### Notes

A licensed electrician must wire the junction box to the Chicago power receptacle (BVE07.), ordered separately.

### Dimensions

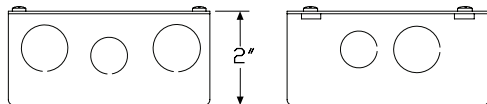
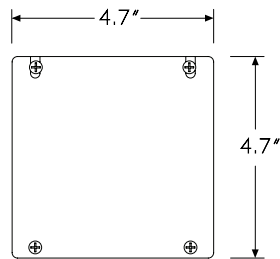

## Specification Information

### Step 1.

**BVE08.**

\$71

Logic HD Cable Manager

Y1424.

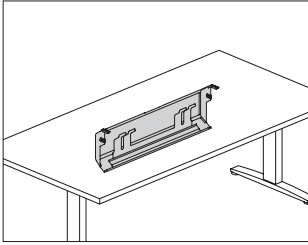

**Product Information**

**Description**  
 This Logic Power Access Solutions™ stand-alone cable management tray mounts to the underside of most surfaces. It can be used with a Logic unit for cord storage, or used alone with cords routed through the back side of the unit. Tray drops down and holds cords in place while working and can be easily stowed back in place.

**Dimensions**

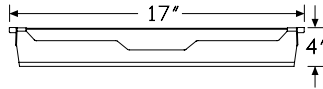
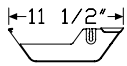

**Specification Information**

**Step 1.**

**Y1424.**  A

**Step 2. Size**

**17** 17" wide tray  A

**Prices for Steps 1-2.**

**Y1424. 17** \$242

**Step 3. Finish**

**91** white  A + \$0

**G1** graphite  A + \$0

**MS** metallic silver  A + \$0

# Power Bridge

BVE09.

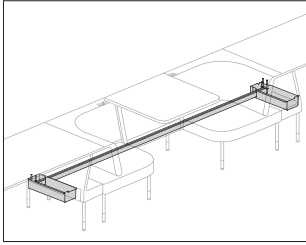

## Product Information

### Description

This kit includes beam to route power jumper and data between power bridge access desks positioned L-shelf-to-L-shelf with or without social chairs and café table between desk configurations. Attachment hardware included. Power components must be ordered separately.

### Notes

Receptacle over only option (NB) supports desk back-to-back configurations with a single or double café and power bridge desk located on left or right side.

Jumper tray only option (00) covers the power block and desk jumper in back-to-back L-shelf configurations with the power bridge desk.

Short bridge option (29) connects L-shelf-to-desk bin configurations with a single social chair between desks. At least 1 desk must be the power bridge desk.

Long bridge option (87) connects L-shelf-to-L-shelf in desk side-to-side configurations with a café table between the power bridge desks.

See Planning Guide for more information about settings.

## Dimensions

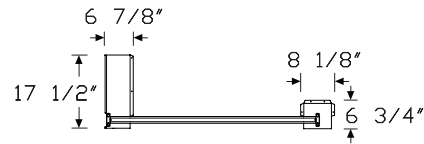

Short Bridge (29)

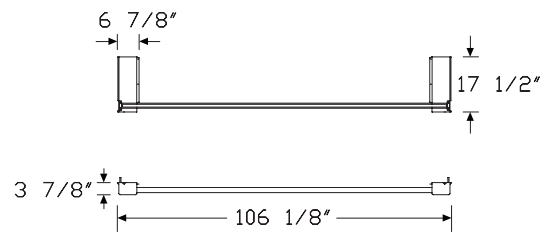

Long Bridge (87)

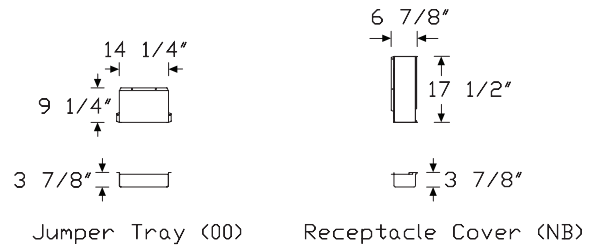

Jumper Tray (00)

Receptacle Cover (NB)

**Specification Information**

Step 1.

**BVE09.**

Step 2. Length

- NB** receptacle cover only
- 00** jumper tray only
- 29** short bridge
- 87** long bridge

Step 3. Desk Bin Orientation

*For receptacle cover only (NB)*

- L** left bin
- R** right bin

*For jumper tray only (00), short bridge (29), or long bridge (87)*

- B** left bin and right bin

Prices for Steps 1-3.

	<b>B</b>	<b>L</b>	<b>R</b>
<b>BVE09. NB</b>	—	\$120	120
<b>00</b>	\$100	—	—
<b>29</b>	\$450	—	—
<b>87</b>	\$650	—	—

Step 4. Finish

- 91** white +\$0
- G1** graphite +\$0
- MS** metallic silver +\$0

# Single Café Table

BVT1.

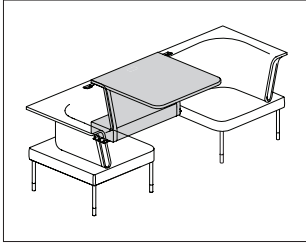

### Product Information

#### Description

This single café table comes with a laminate, veneer, or Formcoat® squared-edge work surface. It has a painted steel shelf, accepts a single 29"-wide screen, and is available with or without power access. Café table includes bag hook. Attachment hardware included.

#### Notes

Single café table cannot stand alone and must attach between 2 social chairs (BVS1N.).

Power access comes with single grommet to accommodate power at the surface. Grommet color is either graphite or white, matched to the work surface color.

To bring power to the surface of a single café table with power access, order Logic Mini, Grommet Mount (Y1414.) separately.

Bag hook color is matched to shelf color.

#### Dimensions

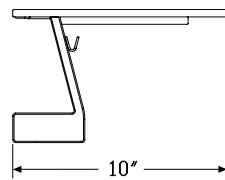
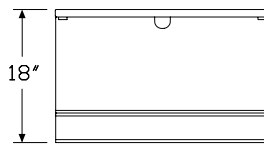
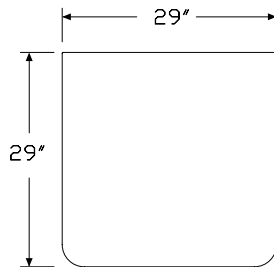

### Specification Information

#### Step 1.

**BVT1.**

#### Step 2. Depth

**29** 29" deep

#### Step 3. Power Access

**P** power access

**N** no power access

#### Step 4. Top Material

**L** laminate top/thermoplastic edge

**T** formcoat®

**W** veneer

#### Prices for Steps 1-4.

		L	T	W
<b>BVT1.</b>	<b>29 P</b>	\$857	900	1028
	<b>N</b>	\$807	848	969

Single Café Table *continued*

Step 5. Top Finish

*For laminate top/thermoplastic edge (L)*

<b>76</b>	light brown walnut	+\$0
<b>8Q</b>	folkstone grey	+\$0
<b>91</b>	white	+\$0
<b>98</b>	studio white	+\$0
<b>CL</b>	cool grey neutral	+\$0
<b>HF</b>	inner tone light	+\$0
<b>HM</b>	natural maple	+\$0
<b>HP</b>	light anigre	+\$0
<b>HT</b>	inner tone	+\$0
<b>HX</b>	aged cherry	+\$0
<b>HY</b>	walnut on cherry	+\$0
<b>LA</b>	light ash	+\$0
<b>LBA</b>	clear on ash	+\$0
<b>LBB</b>	oak on ash	+\$0
<b>LBC</b>	walnut on ash	+\$0
<b>LBD</b>	dark brown walnut	+\$0
<b>LBE</b>	medium red walnut	+\$0
<b>LBF</b>	neutral twill	+\$0
<b>LBG</b>	sarum twill	+\$0
<b>LBH</b>	earthen twill	+\$0
<b>LBJ</b>	graphite twill	+\$0
<b>LBK</b>	pewter mesh	+\$0
<b>LBL</b>	steel mesh	+\$0
<b>LBM</b>	crisp linen	+\$0
<b>LBN</b>	classic linen	+\$0
<b>LBP</b>	casual linen	+\$0
<b>LBQ</b>	white twill	+\$0
<b>LM</b>	mahogany	+\$0
<b>LT</b>	light tone	+\$0
<b>LU</b>	soft white	+\$0
<b>MT</b>	medium tone	+\$0
<b>WL</b>	sandstone	+\$0
<b>WN</b>	warm grey neutral	+\$0

*For formcoat® (T)*

<b>8Q</b>	folkstone grey	+\$0
<b>91</b>	white	+\$0
<b>WL</b>	sandstone	+\$0

*For veneer (W)*

<b>ET</b>	clear on ash	+\$0
<b>EU</b>	oak on ash	+\$0
<b>EV</b>	walnut on ash	+\$0
<b>2U</b>	light brown walnut	+\$0
<b>40</b>	dark brown walnut	+\$0

Step 6. Edge Finish

*For laminate top/thermoplastic edge (L)*

<b>76</b>	light brown walnut	+\$0
<b>8Q</b>	folkstone grey	+\$0
<b>8Z</b>	neutral grey	+\$0
<b>91</b>	white	+\$0
<b>98</b>	studio white	+\$0
<b>BU</b>	black umber	+\$0
<b>CL</b>	cool grey neutral	+\$0
<b>HF</b>	inner tone light	+\$0
<b>HM</b>	natural maple	+\$0
<b>HP</b>	light anigre	+\$0
<b>HT</b>	inner tone	+\$0
<b>HX</b>	aged cherry	+\$0
<b>HY</b>	walnut on cherry	+\$0
<b>JB</b>	millwork cherry	+\$0
<b>LA</b>	light ash	+\$0
<b>LBA</b>	clear on ash	+\$0
<b>LBB</b>	oak on ash	+\$0
<b>LBC</b>	walnut on ash	+\$0
<b>LBD</b>	dark brown walnut	+\$0
<b>LBE</b>	medium red walnut	+\$0
<b>LBF</b>	neutral twill	+\$0
<b>LBG</b>	sarum twill	+\$0
<b>LBH</b>	earthen twill	+\$0
<b>LBJ</b>	graphite twill	+\$0
<b>LBK</b>	pewter mesh	+\$0
<b>LBL</b>	steel mesh	+\$0
<b>LBM</b>	crisp linen	+\$0
<b>LBN</b>	classic linen	+\$0
<b>LBP</b>	casual linen	+\$0
<b>LBQ</b>	white twill	+\$0
<b>LU</b>	soft white	+\$0
<b>MT</b>	medium tone	+\$0
<b>WL</b>	sandstone	+\$0
<b>WN</b>	warm grey neutral	+\$0



## Single Café Table *continued*

---

Step 7. Shelf Finish		
<b>MS</b>	metallic silver	+\$0
<b>G1</b>	graphite	+\$0
<b>91</b>	white	+\$0

---

Step 8. Grommet Selection		
<i>For power access (P)</i>		
<b>91</b>	white	+\$0
<b>G1</b>	graphite	+\$0

# Focus Café Table

BVT2.

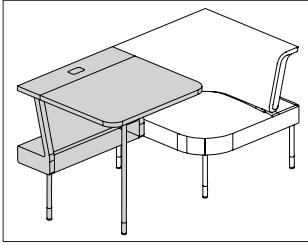

### Product Information

#### Description

The focus café table comes with a laminate, veneer, or Formcoat® squared-edge work surface. It has a painted steel shelf, accepts a single 29"-wide screen, accepts power accessories, and is available with or without power access. Stiffeners, and attachment hardware included.

#### Notes

Focus café table cannot stand alone and must attach to 1 social chair (BVS1N.).

Power accessories in this application will comply with UL 962A.

Power access comes with single grommet to accommodate power at the surface. Grommet color is either graphite or white, matched to the work surface color.

To bring power to the surface of a focus café table with power access, order Logic Mini, Grommet Mount (Y1414.) separately.

#### Dimensions

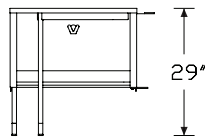
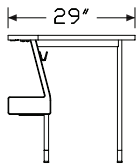
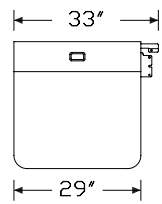

### Specification Information

#### Step 1.

**BVT2.**

#### Step 2. Depth

**29** 29" deep

#### Step 3. Power Access

**P** power access

**N** no power access

#### Step 4. Surface Application

**L** table left

**R** table right

#### Step 5. Top Material

**L** laminate top/thermoplastic edge

**T** formcoat®

**W** veneer

#### Prices for Steps 1-5.

		LL	LT	LW	RL	RT	RW
<b>BVT2.</b>	<b>29 P</b>	\$1191	1251	1430	1191	1251	1430
	<b>N</b>	\$1120	1176	1344	1120	1176	1344

Focus Café Table *continued*

Step 6. Top Finish

*For laminate top/thermoplastic edge (L)*

<b>76</b>	light brown walnut	+\$0
<b>8Q</b>	folkstone grey	+\$0
<b>91</b>	white	+\$0
<b>98</b>	studio white	+\$0
<b>CL</b>	cool grey neutral	+\$0
<b>HF</b>	inner tone light	+\$0
<b>HM</b>	natural maple	+\$0
<b>HP</b>	light anigre	+\$0
<b>HT</b>	inner tone	+\$0
<b>HX</b>	aged cherry	+\$0
<b>HY</b>	walnut on cherry	+\$0
<b>LA</b>	light ash	+\$0
<b>LBA</b>	clear on ash	+\$0
<b>LBB</b>	oak on ash	+\$0
<b>LBC</b>	walnut on ash	+\$0
<b>LBD</b>	dark brown walnut	+\$0
<b>LBE</b>	medium red walnut	+\$0
<b>LBF</b>	neutral twill	+\$0
<b>LBG</b>	sarum twill	+\$0
<b>LBH</b>	earthen twill	+\$0
<b>LBJ</b>	graphite twill	+\$0
<b>LBK</b>	pewter mesh	+\$0
<b>LBL</b>	steel mesh	+\$0
<b>LBM</b>	crisp linen	+\$0
<b>LBN</b>	classic linen	+\$0
<b>LBP</b>	casual linen	+\$0
<b>LBQ</b>	white twill	+\$0
<b>LM</b>	mahogany	+\$0
<b>LT</b>	light tone	+\$0
<b>LU</b>	soft white	+\$0
<b>MT</b>	medium tone	+\$0
<b>WL</b>	sandstone	+\$0
<b>WN</b>	warm grey neutral	+\$0

*For formcoat® (T)*

<b>91</b>	white	+\$0
<b>8Q</b>	folkstone grey	+\$0
<b>WL</b>	sandstone	+\$0

*For veneer (W)*

<b>ET</b>	clear on ash	+\$0
<b>EU</b>	oak on ash	+\$0
<b>EV</b>	walnut on ash	+\$0
<b>2U</b>	light brown walnut	+\$0
<b>40</b>	dark brown walnut	+\$0

Step 7. Edge Finish

*For laminate top/thermoplastic edge (L)*

<b>76</b>	light brown walnut	+\$0
<b>8Q</b>	folkstone grey	+\$0
<b>8Z</b>	neutral grey	+\$0
<b>91</b>	white	+\$0
<b>98</b>	studio white	+\$0
<b>BU</b>	black umber	+\$0
<b>CL</b>	cool grey neutral	+\$0
<b>HF</b>	inner tone light	+\$0
<b>HM</b>	natural maple	+\$0
<b>HP</b>	light anigre	+\$0
<b>HT</b>	inner tone	+\$0
<b>HX</b>	aged cherry	+\$0
<b>HY</b>	walnut on cherry	+\$0
<b>JB</b>	millwork cherry	+\$0
<b>LA</b>	light ash	+\$0
<b>LBA</b>	clear on ash	+\$0
<b>LBB</b>	oak on ash	+\$0
<b>LBC</b>	walnut on ash	+\$0
<b>LBD</b>	dark brown walnut	+\$0
<b>LBE</b>	medium red walnut	+\$0
<b>LBF</b>	neutral twill	+\$0
<b>LBG</b>	sarum twill	+\$0
<b>LBH</b>	earthen twill	+\$0
<b>LBJ</b>	graphite twill	+\$0
<b>LBK</b>	pewter mesh	+\$0
<b>LBL</b>	steel mesh	+\$0
<b>LBM</b>	crisp linen	+\$0
<b>LBN</b>	classic linen	+\$0
<b>LBP</b>	casual linen	+\$0
<b>LBQ</b>	white twill	+\$0
<b>LU</b>	soft white	+\$0
<b>MT</b>	medium tone	+\$0
<b>WL</b>	sandstone	+\$0
<b>WN</b>	warm grey neutral	+\$0

Focus Café Table *continued*

Step 8. Leg Finish

<b>MS</b>	metallic silver	+\$0
<b>G1</b>	graphite	+\$0
<b>91</b>	white	+\$0

Step 9. Shelf Finish

*For metallic silver (MS)*

<b>MS</b>	metallic silver	+\$0
-----------	-----------------	------

*For graphite (G1)*

<b>G1</b>	graphite	+\$0
-----------	----------	------

*For white (91)*

<b>91</b>	white	+\$0
-----------	-------	------

Step 10. Grommet Selection

*For power access (P)*

<b>91</b>	white	+\$0
<b>G1</b>	graphite	+\$0

# Double Café Table

BVT3.

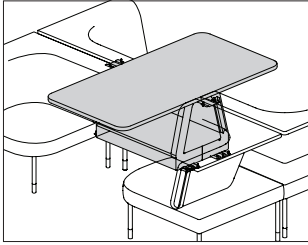

### Product Information

#### Description

This double café table comes with a laminate, veneer, or Formcoat® squared-edge work surface. It has a painted steel shelf and is available with or without power access. Attachment hardware included.

#### Notes

Double café table cannot stand alone and must attach between 4 social chairs (BVS1N.).

Power access comes with 2 grommets to accommodate power at the surface. Grommet color is either graphite or white, matched to the work surface color.

To bring power to the surface of a double café table with power access, order Logic Mini, Grommet Mount (Y1414.) separately.

#### Dimensions

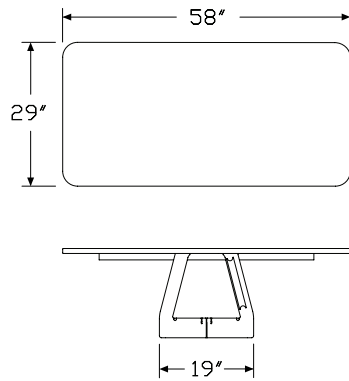

### Specification Information

#### Step 1.

**BVT3.**

#### Step 2. Depth

**29** 29" deep

#### Step 3. Power Access

**P** power access

**N** no power access

#### Step 4. Top Material

**L** laminate top/thermoplastic edge

**T** formcoat®

**W** veneer

#### Prices for Steps 1-4.

		L	T	W
<b>BVT3.</b>	<b>29 P</b>	\$1086	1140	1303
	<b>N</b>	\$1000	1050	1200

# Double Café Table *continued*

## Step 5. Top Finish

### For laminate top/thermoplastic edge (L)

<b>76</b>	light brown walnut	+\$0
<b>8Q</b>	folkstone grey	+\$0
<b>91</b>	white	+\$0
<b>98</b>	studio white	+\$0
<b>CL</b>	cool grey neutral	+\$0
<b>HF</b>	inner tone light	+\$0
<b>HM</b>	natural maple	+\$0
<b>HP</b>	light anigre	+\$0
<b>HT</b>	inner tone	+\$0
<b>HX</b>	aged cherry	+\$0
<b>HY</b>	walnut on cherry	+\$0
<b>LA</b>	light ash	+\$0
<b>LBA</b>	clear on ash	+\$0
<b>LBB</b>	oak on ash	+\$0
<b>LBC</b>	walnut on ash	+\$0
<b>LBD</b>	dark brown walnut	+\$0
<b>LBE</b>	medium red walnut	+\$0
<b>LBF</b>	neutral twill	+\$0
<b>LBG</b>	sarum twill	+\$0
<b>LBH</b>	earthen twill	+\$0
<b>LBJ</b>	graphite twill	+\$0
<b>LBK</b>	pewter mesh	+\$0
<b>LBL</b>	steel mesh	+\$0
<b>LBM</b>	crisp linen	+\$0
<b>LBN</b>	classic linen	+\$0
<b>LBP</b>	casual linen	+\$0
<b>LBQ</b>	white twill	+\$0
<b>LM</b>	mahogany	+\$0
<b>LT</b>	light tone	+\$0
<b>LU</b>	soft white	+\$0
<b>MT</b>	medium tone	+\$0
<b>WL</b>	sandstone	+\$0
<b>WN</b>	warm grey neutral	+\$0

### For formcoat® (T)

<b>8Q</b>	folkstone grey	+\$0
<b>91</b>	white	+\$0
<b>WL</b>	sandstone	+\$0

## For veneer (W)

<b>ET</b>	clear on ash	+\$0
<b>EU</b>	oak on ash	+\$0
<b>EV</b>	walnut on ash	+\$0
<b>2U</b>	light brown walnut	+\$0
<b>40</b>	dark brown walnut	+\$0

## Step 6. Edge Finish

### For laminate top/thermoplastic edge (L)

<b>76</b>	light brown walnut	+\$0
<b>8Q</b>	folkstone grey	+\$0
<b>8Z</b>	neutral grey	+\$0
<b>91</b>	white	+\$0
<b>98</b>	studio white	+\$0
<b>BU</b>	black umber	+\$0
<b>CL</b>	cool grey neutral	+\$0
<b>HF</b>	inner tone light	+\$0
<b>HM</b>	natural maple	+\$0
<b>HP</b>	light anigre	+\$0
<b>HT</b>	inner tone	+\$0
<b>HX</b>	aged cherry	+\$0
<b>HY</b>	walnut on cherry	+\$0
<b>JB</b>	millwork cherry	+\$0
<b>LA</b>	light ash	+\$0
<b>LBA</b>	clear on ash	+\$0
<b>LBB</b>	oak on ash	+\$0
<b>LBC</b>	walnut on ash	+\$0
<b>LBD</b>	dark brown walnut	+\$0
<b>LBE</b>	medium red walnut	+\$0
<b>LBF</b>	neutral twill	+\$0
<b>LBG</b>	sarum twill	+\$0
<b>LBH</b>	earthen twill	+\$0
<b>LBJ</b>	graphite twill	+\$0
<b>LBK</b>	pewter mesh	+\$0
<b>LBL</b>	steel mesh	+\$0
<b>LBM</b>	crisp linen	+\$0
<b>LBN</b>	classic linen	+\$0
<b>LBP</b>	casual linen	+\$0
<b>LBQ</b>	white twill	+\$0
<b>LU</b>	soft white	+\$0
<b>MT</b>	medium tone	+\$0
<b>WL</b>	sandstone	+\$0
<b>WN</b>	warm grey neutral	+\$0

## Double Café Table *continued*

---

Step 7. Shelf Finish		
<b>MS</b>	metallic silver	+\$0
<b>G1</b>	graphite	+\$0
<b>91</b>	white	+\$0

---

Step 8. Grommet Selection		
<i>For power access (P)</i>		
<b>91</b>	white	+\$0
<b>G1</b>	graphite	+\$0

# Peninsula Table

BVT4.

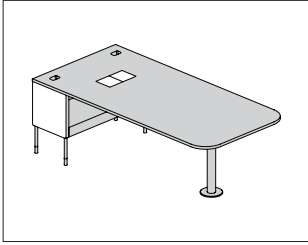

### Product Information

#### Description

This peninsula table comes with a laminate, veneer, or Formcoat® squared-edge work surface. It has a painted steel understructure bin, a column leg, and 2 grommets in the back of the surface. It is available with or without an additional cutout for power access and accepts a single 42"-wide screen. Legs have glides that provide up to 2" of adjustment. Bin divider included.

#### Notes

To connect peninsula table to other freestanding bins, order desk and bin ganging plate (BVD5.) separately.

Bin divider color is specified separately.

The exposed end of the understructure bin requires a desk and bin finishing kit (BVD4.), ordered separately.

Grommet color is either graphite or white, matched to the work surface color.

To bring power to the surface of a peninsula table with power access, order Logic Mini, Grommet Mount (Y1414.) separately.

Doors are not available for the peninsula table understructure bin.

#### Dimensions

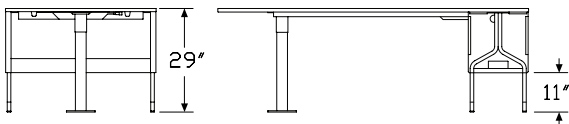
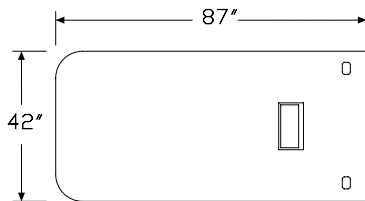

### Specification Information

#### Step 1.

**BVT4.**

#### Step 2. Depth

**42** 42" deep

#### Step 3. Width

**87** 87" wide

#### Step 4. Power Access

**N** no power access

**P** power access

#### Step 5. Doors

**N** no doors

#### Step 6. Top Material

**L** laminate top/thermoplastic edge

**T** formcoat®

**W** veneer

#### Prices for Steps 1-6.

		<b>NNL</b>	<b>NNT</b>	<b>NNW</b>	<b>PNL</b>	<b>PNT</b>	<b>PNW</b>
<b>BVT4.</b>	<b>42 87</b>	\$2429	2550	2914	2429	2550	2914



Step 7. Top Finish

*For laminate top/thermoplastic edge (L)*

<b>76</b>	light brown walnut	+\$0
<b>8Q</b>	folkstone grey	+\$0
<b>91</b>	white	+\$0
<b>98</b>	studio white	+\$0
<b>CL</b>	cool grey neutral	+\$0
<b>HF</b>	inner tone light	+\$0
<b>HM</b>	natural maple	+\$0
<b>HP</b>	light anigre	+\$0
<b>HT</b>	inner tone	+\$0
<b>HX</b>	aged cherry	+\$0
<b>HY</b>	walnut on cherry	+\$0
<b>LA</b>	light ash	+\$0
<b>LBA</b>	clear on ash	+\$0
<b>LBB</b>	oak on ash	+\$0
<b>LBC</b>	walnut on ash	+\$0
<b>LBD</b>	dark brown walnut	+\$0
<b>LBE</b>	medium red walnut	+\$0
<b>LBF</b>	neutral twill	+\$0
<b>LBG</b>	sarum twill	+\$0
<b>LBH</b>	earthen twill	+\$0
<b>LBJ</b>	graphite twill	+\$0
<b>LBK</b>	pewter mesh	+\$0
<b>LBL</b>	steel mesh	+\$0
<b>LBM</b>	crisp linen	+\$0
<b>LBN</b>	classic linen	+\$0
<b>LBP</b>	casual linen	+\$0
<b>LBQ</b>	white twill	+\$0
<b>LM</b>	mahogany	+\$0
<b>LT</b>	light tone	+\$0
<b>LU</b>	soft white	+\$0
<b>MT</b>	medium tone	+\$0
<b>WL</b>	sandstone	+\$0
<b>WN</b>	warm grey neutral	+\$0

*For formcoat® (T)*

<b>8Q</b>	folkstone grey	+\$0
<b>91</b>	white	+\$0
<b>WL</b>	sandstone	+\$0

*For veneer (W)*

<b>ET</b>	clear on ash	+\$0
<b>EU</b>	oak on ash	+\$0
<b>EV</b>	walnut on ash	+\$0
<b>2U</b>	light brown walnut	+\$0
<b>40</b>	dark brown walnut	+\$0

Step 8. Edge Finish

*For laminate top/thermoplastic edge (L)*

<b>76</b>	light brown walnut	+\$0
<b>8Q</b>	folkstone grey	+\$0
<b>8Z</b>	neutral grey	+\$0
<b>91</b>	white	+\$0
<b>98</b>	studio white	+\$0
<b>BU</b>	black umber	+\$0
<b>CL</b>	cool grey neutral	+\$0
<b>HF</b>	inner tone light	+\$0
<b>HM</b>	natural maple	+\$0
<b>HP</b>	light anigre	+\$0
<b>HT</b>	inner tone	+\$0
<b>HX</b>	aged cherry	+\$0
<b>HY</b>	walnut on cherry	+\$0
<b>JB</b>	millwork cherry	+\$0
<b>LA</b>	light ash	+\$0
<b>LBA</b>	clear on ash	+\$0
<b>LBB</b>	oak on ash	+\$0
<b>LBC</b>	walnut on ash	+\$0
<b>LBD</b>	dark brown walnut	+\$0
<b>LBE</b>	medium red walnut	+\$0
<b>LBF</b>	neutral twill	+\$0
<b>LBG</b>	sarum twill	+\$0
<b>LBH</b>	earthen twill	+\$0
<b>LBJ</b>	graphite twill	+\$0
<b>LBK</b>	pewter mesh	+\$0
<b>LBL</b>	steel mesh	+\$0
<b>LBM</b>	crisp linen	+\$0
<b>LBN</b>	classic linen	+\$0
<b>LBP</b>	casual linen	+\$0
<b>LBQ</b>	white twill	+\$0
<b>LU</b>	soft white	+\$0
<b>MT</b>	medium tone	+\$0
<b>WL</b>	sandstone	+\$0
<b>WN</b>	warm grey neutral	+\$0

Peninsula Table *continued*

Public Office Landscape® Tables

Step 9. Leg Finish

<b>MS</b>	metallic silver	+\$0
<b>G1</b>	graphite	+\$0
<b>91</b>	white	+\$0

Step 10. Bin/Bin Doors Finish

*For metallic silver (MS)*

<b>MS</b>	metallic silver	+\$0
-----------	-----------------	------

*For graphite (G1)*

<b>G1</b>	graphite	+\$0
-----------	----------	------

*For white (91)*

<b>91</b>	white	+\$0
-----------	-------	------

Step 11. Bin Divider Color

<b>MS</b>	metallic silver	+\$0
<b>G1</b>	graphite	+\$0
<b>91</b>	white	+\$0
<b>RO</b>	red	+\$30
<b>79</b>	green apple	+\$30
<b>TRQ</b>	turquoise	+\$30
<b>MY3</b>	yellow oxide	+\$30
<b>SG</b>	slate grey	+\$0

Step 12. Grommet Selection

<b>91</b>	white	+\$0
<b>G1</b>	graphite	+\$0

# Screens - Single Material

BVP1.

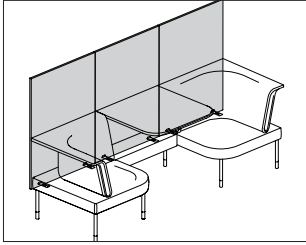

### Product Information

#### Description

Screens attach to social chairs, sectional seats, desks, single café tables, peninsula tables, and freestanding bins. They are tackable, have a single fabric covering the entire screen, and come in 2 widths and 3 heights. Attachment is by a push-button mechanism.

#### Notes

For attachment to a social chair (BVS1N.), sectional seat (BVS2N.), single café table (BVT1.) and 29" freestanding bin (BVB1.29), specify 29"-wide screen. For attachment to peninsula table (BVT4.) and 42" freestanding bin (BVB1.42), specify 42"-wide screen.

Applications with adjacent screens in a line or at a corner require alignment clip (BVP3.), ordered separately.

Screens accept whiteboard overhang (BVP4.), ordered separately.

Screen accepts Customer's Own Material (COM). Yardage is estimated for nondirectional 54"-wide fabrics.

#### Height—Yardage

42—2.33

54—3.09

68—3.97

For information on multiple quantities or directional fabrics, contact COM Department. See Order Information in Appendices.

### Dimensions

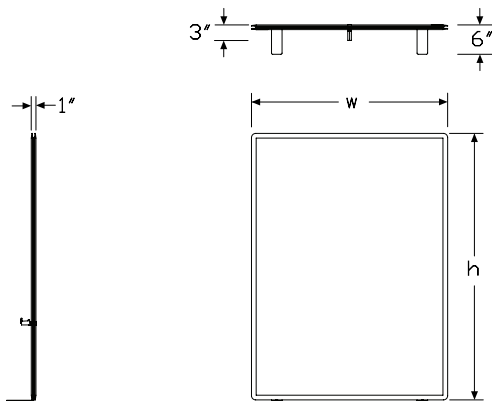

### Specification Information

#### Step 1.

**BVP1.**

#### Step 2. Width

**29** 29" wide

**42** 42" wide

#### Step 3. Height

**42** 42" high

**54** 54" high

**68** 68" high

#### Step 4. Screen Material

**F** fabric

#### Prices for Steps 1-4.

		<b>F</b>
<b>BVP1.</b>	<b>29 42</b>	\$643
	<b>54</b>	\$829
	<b>68</b>	\$986
	<b>42 42</b>	\$843
	<b>54</b>	\$1029
	<b>68</b>	\$1114

#### Step 5. Fabric

	<b>42F</b>	<b>54F</b>	<b>68F</b>
Price Category 1	+\$0	0	0
Price Category 2	+\$22	28	36
Price Category 3	+\$50	66	86
Price Category 4	+\$88	110	141
Price Category E	+\$203	279	349

# Screen and Desktop Divider Alignment Kit

BVP3.

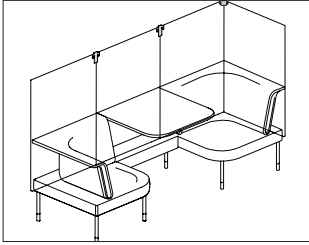

## Product Information

**Description**  
This clip comes in 2 types to align screens and desktop dividers either in a line or at a corner. Clip finish is metallic silver (MS).

**Notes**  
For use with the desktop divider (BVP5.), only the straight alignment clip is recommended.

## Dimensions

## Specification Information

Step 1.

**BVP3.**

Step 2. Application

- S** straight
- C** corner

Prices for Steps 1-2.

<b>BVP3. S</b>	\$11
<b>C</b>	\$22

Public Office Landscape® Space Delineation

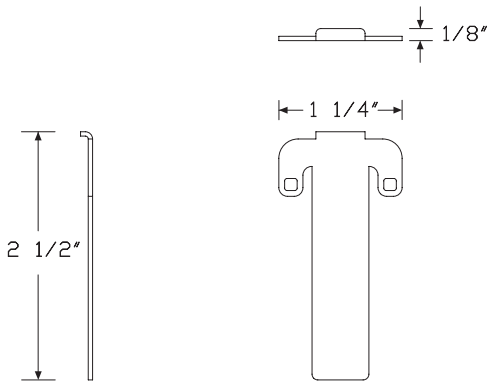

Straight

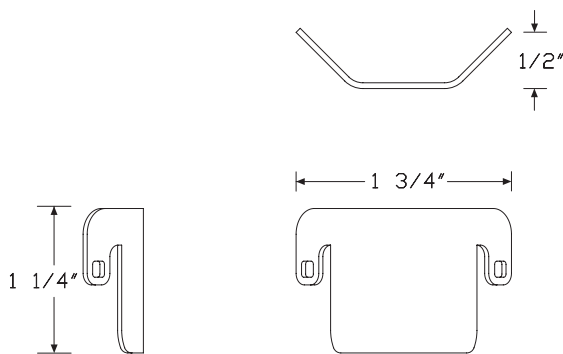

Corner

# Whiteboard Overhang

BVP4.

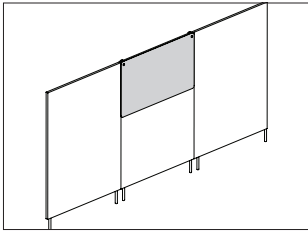

### Product Information

#### Description

This whiteboard hangs over a screen. It is 25" high when used on 54"-high screens, and 39" high when used on 68"-high screens. Available in 29" and 42" widths to match screen width. Bracket finish is metallic silver (MS).

#### Notes

Available for 54"-high and 68"-high screens only.  
A screen can support only a single whiteboard overhang.

#### Dimensions

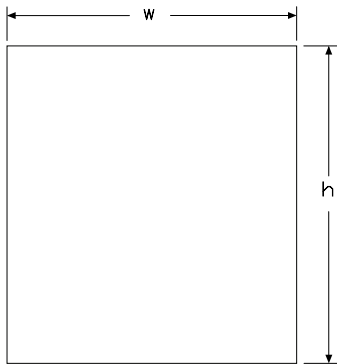

### Specification Information

#### Step 1.

**BVP4.**

#### Step 2. Width

**29** 29" wide  
**42** 42" wide

#### Step 3. Height

**54** 54" high  
**68** 68" high

#### Prices for Steps 1-3.

		54	68
<b>BVP4.</b>	<b>29</b>	\$429	571
	<b>42</b>	\$571	714

# Desktop Divider

BVP5.

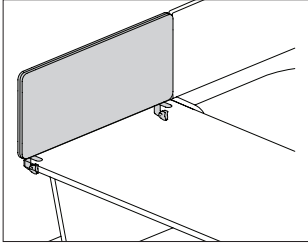

## Product Information

### Description

This 13"-high fabric-covered divider is mounted to, or freestanding on, desks, tables, and connecting bins. Attachment hardware is included and comes standard in metallic silver (MS) finish.

### Notes

Applications with adjacent dividers in a line require alignment clip (BVP3.S), ordered separately.

Divider accepts Customer's Own Material (COM). Yardage is estimated for nondirectional 54"-wide fabrics.

### Width—Yardage

29—1.10

58—1.92

For information on multiple quantities or directional fabrics, contact COM Department. See Order Information in Appendices.

## Dimensions

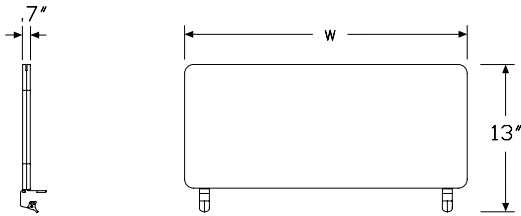

## Specification Information

### Step 1.

**BVP5.**

### Step 2. Height

**13** 13" high

### Step 3. Width

**29** 29" wide

**58** 58" wide

### Step 4. Material

**F** fabric

### Step 5. Attachment Location

**F** freestanding base

**S** side clamp

### Prices for Steps 1-5.

		FF	FS
<b>BVP5.</b>	<b>13 29</b>	\$367	367
	<b>58</b>	\$506	506

### Step 6. Fabric

Price Category 1	+\$0
Price Category 2	+\$11
Price Category 3	+\$28
Price Category 4	+\$44
Price Category E	+\$131

## Index by Product Name

<b>Public Office Landscape®</b>	
Chicago Power - Controlled Duplex	page(s) 38
Chicago Power - Duplex	37
Chicago Power - Junction Box	43
Connecting Bin	15
Controlled Receptacle Decal (12 per sheet)	39
Corded Power Solution	36
Desk	12
Desk and Bin Finishing Kit	27
Desk and Bin Ganging Plate	28
Desktop Divider	62
Double Café Table	53
Focus Café Table	50
Freestanding Bin	21
Half Bin	24
Legs	9
Logic G1200 Grommet Pass Thru	42
Logic HD Cable Manager	44
Logic Mini	40
Modular Power Controlled Duplex	34
Modular Power Duplex	33
Modular Power Entry	30
Modular Power Entry, New York	31
Peninsula Table	56
Power Block	32
Power Block-to-Power Block Jumper	35
Power Bridge	45
Screen and Desktop Divider Alignment Kit	60
Screens - Single Material	59
Seat Back Alignment Clip	11
Seat Back Ganging Kit	10
Sectional Seating	7
Single Café Table	47
Social Chair	5
Upper Bin	18
Whiteboard Overhang	61





## Index by Product Number

BVB1. Freestanding Bin	page(s) 21
BVB2. Half Bin	24
BVD1. Desk	12
BVD2. Connecting Bin	15
BVD3. Upper Bin	18
BVD4. Desk and Bin Finishing Kit	27
BVD5. Desk and Bin Ganging Plate	28
BVE01. Modular Power Entry	30
BVE02. Modular Power Entry, New York	31
BVE03. Power Block	32
BVE04M Modular Power Controlled Duplex	34
BVE04. Modular Power Duplex	33
BVE05. Power Block-to-Power Block Jumper	35
BVE06. Corded Power Solution	36
BVE07. Chicago Power - Duplex	37
BVE07M Chicago Power - Controlled Duplex	38
BVE08. Chicago Power - Junction Box	43
BVE09. Power Bridge	45
BVP1. Screens - Single Material	59
BVP3. Screen and Desktop Divider Alignment Kit	60
BVP4. Whiteboard Overhang	61
BVP5. Desktop Divider	62
BVS1N. Social Chair	5
BVS2N. Sectional Seating	7
BVS3. Legs	9
BVS4. Seat Back Ganging Kit	10
BVS5. Seat Back Alignment Clip	11
BVT1. Single Café Table	47
BVT2. Focus Café Table	50
BVT3. Double Café Table	53
BVT4. Peninsula Table	56
G9999. Controlled Receptacle Decal (12 per sheet)	39
Y1414. Logic Mini	40
Y1420. Logic G1200 Grommet Pass Thru	42
Y1424. Logic HD Cable Manager	44



## 20-Day or Less/Assigned Lead-Time Order Information

### 20-Day or Less and Assigned Lead-Time Programs

20-day or less and assigned lead-time products are designed for established Herman Miller dealers with pre-approved credit.

Products are distributed from multiple manufacturing facilities across the United States. All products and options not designated by an Assigned Lead-Time icon **A** will ship in 20 business days or less after being acknowledged by Herman Miller. Products and options designated by an **A** are on the assigned lead-time program and will ship in 20 days, less than 20 days, or more than 20 days from order acknowledgement.

### Ordering Procedure

Please place orders through Order Manager. If this is not available to you, place orders through mail or fax. Verbal purchase orders will not be accepted.

Order Entry fax number for Passage®, 5000 Series, and Meridian® Filing and Storage: (616) 846 9236.

Order Entry fax number for all other products:  
(616) 654 3085.

For more information, contact your Customer Care representative at:  
(866) 854 3048 EXT 3400.

### Shipments and Delivery

Per Herman Miller Terms and Conditions.

### Changes and Cancellation

Per Herman Miller Terms and Conditions.



# Customer's Own Material Order Information — Workspaces

## Customer's Own Material

### Program Overview

The Customer's Own Material (COM) program gives you the option of using textiles other than those listed. Herman Miller will test textiles for application to Herman Miller products and will process orders for those with approved COM textiles only. COM textiles are on assigned lead times.

Omni lists an overview of fabrics that have been tested and indicates whether or not they were approved for application to Herman Miller products.

Specific information on the terms and conditions, testing, approval, and ordering process for COM is listed below. Questions about the COM program and requests for assistance may be directed to your COM representative at:

(616) 654 3400

(866) 854 3048 EXT 6543400

### Customer's Own Material Warranty

Herman Miller does not warrant COM textiles. COM textiles are tested for application only; they are not tested for performance. The Herman Miller warranty does apply to the underlying products.

Suppliers of COM textiles are responsible for color consistency within commercial tolerances, UV stability, and resistance to soiling and perspiration.

### Customer's Own Material Pricing

COM is a Category 1 fabric. There are no application charges for COM fabrics.

Ordering and payment for COM textile yardage are the responsibility of the customer and the textile supplier.

If desired, Herman Miller will purchase COM textiles directly from True Textiles, C.F. Stinson, Luna Textiles, Maharam, and Momentum Textiles to simplify ordering and shipment. For this service, refer to the Supplier Connection program.

### Application Note

Herman Miller does not guarantee that Customer's Own Material (COM) fabric patterns will align across panels/tiles or from one screen to the next. We also do not guarantee that COM fabric designs will be positioned consistently in the same location across several panels, tiles, or screens.

### Textile Approval

1. Select a COM textile and a Herman Miller product.
2. If your textile is not listed in Omni, obtain a test number from a COM representative at (616) 654 3400. You can also submit your request within Omni. Please have the following information ready before calling: textile name, number, pattern, and the product you will apply it to.
3. Herman Miller will notify you of approval or disapproval within 4 days from receipt of the test yardage.

### Ordering Products with COM

1. Refer to the specific products to determine the yardage required for COM textiles.
2. If your textile is not listed in Omni, call a COM representative at (616) 654 3400 or (866) 854 3048 EXT 6543400. The representative will assign an identification number for your textile (ID#) and will verify yardage requirements for your order.

*Note: Yardage requirements are based on nondirectional, 54"-wide textiles. 66"-wide textiles are needed for application on 60"-wide products. Additional yardage may be needed due to the unique characteristics of a textile.*

3. Enter your order on Order Manager in Omni.
4. Upon receipt of your purchase order, Herman Miller will send you a PO acknowledgment.
5. Arrangements must be made for the textiles to be shipped from the supplier to Herman Miller for application to the Herman Miller products. Textiles must be tagged with the assigned identification number and the roll yardage quantity. See Omni for shipping procedures and current shipping addresses or contact a COM representative at (616) 654 3400 or (866) 854 3048 EXT 6543400.

Products will be scheduled for production when COM textiles are received at Herman Miller. Standard lead times in effect at that time will apply.

*Note: If textiles are to be purchased directly by Herman Miller through the Supplier Connection program, Herman Miller will handle the ordering and shipping process and will schedule your order for production upon receipt of your purchase order (dependent on textile availability). Refer to the Supplier Connection program for more information.*

# Customer's Own Material Order Information — Workspaces

*continued*

## Supplier Connection

### Program Overview

The Supplier Connection program is a service offered by Herman Miller to purchase approved COM textiles directly from True Textiles, C.F. Stinson, Luna Textiles, Maharam, and Momentum Textiles. When you select a textile through this program, Herman Miller will facilitate the ordering, scheduling, and shipment of the textile directly with the supplier.

Suppliers included in the Supplier Connection program keep an active inventory of textiles that are pre-approved for application to Herman Miller products. Pre-approval applies only to the suitability of a textile for manufacturing and application to a Herman Miller product. Omni provides an overview of fabrics that have been tested and indicates whether or not they were approved for application to Herman Miller products.

Specific information on the terms and conditions, testing, approval, and ordering process for the Supplier Connection program is listed below. Questions and requests for assistance may be directed to your COM representative at:

(616) 654 3400

(866) 854 3048 EXT 6543400

### Supplier Connection Warranty

Textiles purchased by Herman Miller through the Supplier Connection program are COM and are not warranted by Herman Miller. COM textiles are tested for application only; they are not tested for performance. The Herman Miller warranty does apply to the underlying products.

Suppliers of COM textiles are responsible for color consistency within commercial tolerances, UV stability, and resistance to soiling and perspiration.

### Supplier Connection Pricing

Textiles purchased by Herman Miller through the Supplier Connection program are COM. COM is a Category 1 fabric. There are no application charges for COM fabrics.

Payment for textiles purchased by Herman Miller through the Supplier Connection program is the responsibility of the customer or dealer. Herman Miller will invoice the order at the supplier's prices published at the time of the order.

### Textile Approval

1. Refer to Omni to identify the approval status of the textile. If your textile is not listed, contact the COM Department to request testing for application to Herman Miller products.
2. Herman Miller will notify you of approval or disapproval in approximately 4 days from receipt of the test yardage. If the textile is approved, it will be assigned a COM identification number.

### Ordering Products with Supplier Connection COM

1. Identify and include the following information on your purchase order:
  - Product number and option
  - Herman Miller's COM identification number
2. Enter your order on Order Manager in Omni.
3. Upon receipt of the purchase order, Herman Miller will process your order and send you a PO acknowledgment. Herman Miller will determine the yardage required to produce your product and will order and schedule for delivery the required textile. Standard lead times in effect at the time the textile is allocated at the supplier will apply to products ordered through this program.

# Proprietary Textiles Application Chart — Workspaces

• Available

[A] Assigned lead-time textile.

See page 3 for exception notes.

	Action Office® Panels/Connectors	Action Office/Ethospace® B-Style Storage	Action Office B-Style Trackboards	Action Office/Ethospace E-Style Storage	Ethospace Tiles/Connectors	Ethospace Work Surface-Attached Screens	Ethospace/Canvas Office Landscape® Privacy Doors	Canvas Tiles/Extended Width Tiles	Canvas B-/E-Style Storage	Canvas Standing Screen and Team Wall Infill	Canvas Trackboards	Layout Studio® Framed Screen	Locale® Display Trackboard	Locale Freestanding Screen and Workbase Screen	Locale L-Desk/D-Desk Screens	Part™ Screens	Prospect™ Exterior Acoustic Pad	Public Office Landscape® Screen/Desk Top Divider	Renew™ Link Screens	Resolve® Boundary Screens/Flags	Resolve Display Screens	Resolve Rolling Screens/Canopies	Exclave® Tackable Boards and Stowage Tackable Backdrop	Exclave Video-Friendly Tackable Boards and Stowage Tackable Backdrop	Intersect® Screens	Thrive® Personal Side Screen	Tu® Wood Storage Cubby Trackboard	5000 Series Storage and Trackboards	Seating
<b>Price Category 1</b>																													
COM Customer's Own Material [A]	1	1	1	1	1		1	1	1	1	•	1	1	1		1		1	1	1					1	1		3	1
8A__ Bubbletack™																					•								
2V__ Chain	•	•	•	•	•		•	22	•	•	•	•	•	•	•	•	•	•	•						•	•	•	3	
8T__ Crossing (85__)	2	2	2	•	•		•	•	2	•	•	•	•	•	•	•	•	•	•				•	8	•	•	•	3	18
95__ Gem	2	2	2	•	•		•	•	2	•	•	•	•	•	•	•	•	•	•						•	•	•	3	•
2I__ Grasscloth	•	•	•	•	•		•	•	•	•	•	•	•	•	•	•	•	•	•						•	•	•	3	
1MN__ Monologue	2	2	2	•	•		•	•	2	•	•	•	•	•	•	•	•	•	•						•	•	•		•
8B__ Multiscrim™						•														•		•							
5T__ Resonance	•	•	•	•	•		•	•	•	•	•	•	•	•	•	•	•	•	•						•	•	•		
8C__ Scrim Trim																						•							
2M__ Silkworm	•	•	•	•	•		•	•	•	•	•	•	•	•	•	•	•	•	•						•	•	•	3	
22F__ Slant	6		•		•		•	•		•	•	•	•	•	•	•	•	•	•						•		•	3	
235__ Tailored [A]	•	•		•	•		•	•	•	•	•	•	•	•	•	•	•	•	•						•	•	•		•
1WS__ Whisper	2	2	2	•	•		•	•	2	•	•	•	•	•	•	•	•	•	•						•	•			•
<b>Price Category 2</b>																													
1CD__ Code	•	•	•	•	•		•	•	•	•	•	•	•	•	•	•	•	•	•				•		•				
3P__ ColorGuard		2		•																									•
51__ Cord	•	•	•	•	•		•	•	•	•	•	•	•	•	•	•	•	•	•						•	•	•	3	
92__ Crepe	2	•	•	•	•		•	•	•	•	•	•	•	•	•	•	•	•	•				•	8	•	•	•	3	•
22Q__ Fish Net		2	2	•	•		•	•	2		•					•			•										•
57__ Frost	•	•	•	•	•		•	•	•	•	•	•	•	•	•	•	•	•	•						•	•	•	3	
84__ Grosgrain	4	•	•	•	•		•	•	•	•	•	•	•	•	•	•	•	•	•						•	•	•	19	3
4N__ Horizon	2	2	2	•	•		•	•	•	•	•	•	•	•	•	•	•	•	•						•	•	•	3	
1LM__ Loom	2	2	2	•	•		•	•	•	•	•	•	•	•	•	•	•	•	•				•		•				•
1HA__ Medley	2	2	2	•	•		•	•	•	•	•	•	•	•	•	•	•	•	•				•	8	•	•			•
3A__ Moiré		2	2	•	•		•	22	2	•	•	•	•	•	•	•	•	•	•								•	3	•
1RV__ Rivet	2	2	2	•	•		•	•	2	•	•		•		•	•	•	•	•							•	•		•
43__ Tape													•															•	
8R__ Twist (5S__)	5	2	2	•	•		•	•	2	•	•	•	•	•	•	•	•	•	•						•	•	•	3	18
22T__ Well Suited		2		•	•		•	2	•																				•
<b>Price Category 3</b>																													
70__ Bento	2	2	2	•			•	2	•	•		•	•	•	•	•	•	•						•	•	•	3	•	
1FB__ Connection	•	•	•	•	•		•	•	•	•	•	•	•	•	•	•	•	•	•						•	•	•	3	
1FC__ Current	•	•	•	•	•		•	•	•	•	•	•	•	•	•	•	•	•	•						•	•	•	3	
8Z__ Glaze	•	•	•	•	•		•	•	•	•	•	•	•	•	•	•	•	•	•						•	•	•	3	
47__ Ground Cloth®	•	•	•	•	•		•	•	•	•	•	•	•	•	•	•	•	•	•				•	8	•	•	•	3	
5D__ Kira 2	2	2	2	•	•		•	•	2	•	•	•	•	•	•	•	•	•	•						•	•	•	3	
22R__ Pins and Needles	2	2		•	•		•	•	2	•	•	•	•	•	•	•	•	•	•						•				•
8L__ Savannah	•	20		•	•		•	•	•	•	•	•	•	•	•	•	•	•	•								•		
8U__ Stitches (5Z__)	2	2	2	•			•	2	•	•	•	•	•	•	•	•	•	•	•						•	•	•	3	18
8W__ Strands	•	•	•	•	•		•	•	•	•	•	•	•	•	•	•	•	•	•						•	•	•	3	
22V__ String Plaid	2	2	2	•	•		•	•	2	•	•	•	•	•	•	•	•	•	•						•	•			•

continued on next page

# Proprietary Textiles Application Chart — Workspaces

continued

	Action Office® Panels/Connectors	Action Office/Ethospace® B-Style Storage	Action Office B-Style Tackboards	Action Office/Ethospace E-Style Storage	Ethospace Tiles/Connectors	Ethospace Work Surface-Attached Screens	Ethospace/Canvas Office Landscape® Privacy Doors	Canvas Tiles/Extended Width Tiles	Canvas B-/E-Style Storage	Canvas Standing Screen and Team Wall Infill	Canvas Tackboards	Layout Studio® Framed Screen	Locale® Display Tackboard	Locale Freestanding Screen and Workbase Screen	Locale L-Desk/D-Desk Screens	Pari™ Screens	Prospect™ Exterior Acoustic Pad	Public Office Landscape® Screen/Desk Top Divider	Renew™ Link Screens	Resolve® Boundary Screens/Flags	Resolve Display Screens	Resolve Rolling Screens/Canopies	Exclave® Tackable Boards and Stowage Tackable Backdrop	Exclave Video-Friendly Tackable Boards and Stowage Tackable Backdrop	Intersect® Screens	Thrive® Personal Side Screen	Tu® Wood Storage Cubby Tackboard	5000 Series Storage and Tackboards	Seating	
<b>Price Category 4</b>																														
2X__ Glisten	•	•	•	•	•		•	•	•	•	•	•	•																	
22L__ Loft [A]		2	2	•	•		•	•	2	•	•	•	•	•	•	•							•	•	•	•	•	•	•	
6S__ Quilty	2	2	2	•	•		•	•	2			•	•																	
63__ Sironetta	•	•	•	•	•		•	•	•	•	•	•	•	•	•	•									•	•	•	•	•	
<b>Price Category 5</b>																														
14A__ Hopsak	2	2	2	•	•		•	2	•	•	•	•	•										•		•		•		•	
<b>Price Category 6</b>																														
No fabrics available at this time.																														

- 1 Refer to price book appendices and Omni for COM information.
- 2 Available on all products except 54" and 60" wide.
- 3 Fabric is railroaded for all widths.
- 4 Not available on Action Office (AO) acoustical panels.
- 5 (8R\_\_), (8T\_\_), (85\_\_), and (5S\_\_) not available on AO acoustical panels and not available on 54"- or 60"-wide products.
- 6 Not available on Action Office (AO) connectors, cable management, and spacers.
- 8 Available in select colors. See the "Proprietary Textile Colors — Workspaces" appendix.
- 14 Not available on Resolve flags.
- 18 Available on seating products in select colors. See the "Proprietary Textile Colors — Seating" appendix.
- 19 Not available in Grosgrain (84\_\_) fabric colors 8401, 8405, and 8413.
- 20 Available only on Ethospace B-Style.
- 22 Not available as railroaded application option for Chain (2Voo) and Moiré (3Aoo) on Canvas Extended Width Tiles.
- 24 Not available on Ethospace cable access tile, cable channel tile, or beltline face tile.

Application Note: Herman Miller cannot guarantee material/pattern alignment in adjacent products. For example, a fabric's pattern may not align from one screen to the next, or from one panel to the next.



# Proprietary Textile Colors — Workspaces

## Price Category 1

**Customer's Own Material**  
See Order Information in  
Appendices.  
Assigned lead-time textile. A

**Bubbletack™**  
100% polyester

8A01	Seashell White
8A02	Pearl Grey
8A05	Dune Beige
8A07	Pebble Beige
8A09	Olive Green
8A13	Slate Purple
8A19	Spa Blue
8A24	Sable Grey
8A27	Summer White
8A28	Moth Grey
8A29	Tea Leaf Grey
8A30	Blue Grey
8A31	Dusty Bronze
8A32	Slate Blue
8A33	Caramel Beige
8A34	Kiwi Green

**Chain**  
66" wide  
100% recycled polyester

2V01	Pearl
2V02	Oyster
2V03	Wheat
2V04	Linen
2V05	Wicker
2V06	Bamboo
2V07	Sage
2V08	Spring Wood
2V09	Iceberg

**Crossing**  
54" wide  
86% antimony-free polyester  
14% polyester

8T03	Wicker *
8T04	Porcelain *
8T05	Warm Grey *
8T06	Sepia
8T07	Pumpkin
8T08	Copper
8T09	Cranberry
8T10	Tomato
8T11	Mulberry
8T12	Plum
8T13	Green Apple
8T14	Loden
8T15	Spruce
8T16	Periwinkle
8T17	Cerulean
8T18	Indigo
8T19	Shale *
8T20	Brownstone
8T21	Bark
8T22	Tin *
8T23	Graphite
8T24	Black

**Crossing**  
For workspaces products only.  
54" wide  
86% antimony-free polyester  
14% polyester

8501	Ivory *
8502	Oyster *

\* Colors available on Exclave®  
Video-friendly Tackable  
Boards and Stowage Tackable  
Backdrop

**Gem**  
54" wide  
100% antimony-free polyester

9501	Sesame
9502	Tangerine
9503	Red
9504	Red Violet
9505	Mulberry
9506	Java
9507	Twilight
9508	Bayou
9509	Iris
9510	Berry Blue
9511	Aqua Green
9512	Green Apple
9513	Spruce
9514	Black
9515	Slate Grey
9516	Fog

**Grasscloth**  
66" wide  
100% recycled polyester

2I01	Silver Birch
2I02	Pampas
2I03	Sedge
2I07	Lea
2I08	Taro
2I09	Steam Grey
2I10	Cayenne
2I11	Bottle Green
2I12	Surf
2I13	Gravel

**Monologue**  
54" wide  
56% recycled polyester  
44% polyester

1MN01	Linen
1MN02	Alabaster
1MN03	Truffle
1MN04	Folkstone
1MN05	Silver Pine
1MN06	Slate
1MN07	Seed
1MN08	Yellow Oxide
1MN09	Persimmon
1MN10	Tundra
1MN11	Meadow
1MN12	Blue Sky
1MN13	Blue Spruce
1MN14	Deep Sea

**Multiscrim™**  
60" wide  
100% polyester

8B01	Seashell White
8B02	Pearl Grey
8B05	Dune Beige
8B07	Pebble Beige
8B09	Olive Green
8B15	Slate Purple
8B19	Spa Blue
8B24	Sable Grey
8B27	Summer White
8B28	Moth Grey
8B29	ea Leaf Grey
8B30	Blue Grey
8B31	Dusty Bronze
8B32	Slate Blue
8B33	Caramel Beige
8B34	Kiwi Green

# Proprietary Textile Colors — Workspaces

continued

## Price Category 1

continued

### Resonance

66" wide	
100% polyester	
5T04	Greige
5T05	Porcelain
5T06	Alabaster
5T15	Iris
5T28	Sugar
5T47	Tobacco
5T54	Saltbush
5T57	Seed
5T58	Sepia
5T59	Tundra
5T60	Iceberg
5T61	Black
5T62	Chamois
5T63	Citrus
5T64	Tangerine
5T65	Red
5T66	Wild Berry
5T67	Boysenberry
5T68	Pistachio
5T69	Green Apple
5T70	Forest
5T71	Jade
5T72	Blue Green
5T73	Bright Turquoise
5T74	Twilight

### Scrim Trim

61" wide	
82% polyester	
18% spandex	
8C01	Seashell White
8C02	earl Grey
8C22	Winter Grey
8C24	Sable Grey

### Silkworm

66" wide	
58% recycled polyester	
42% polyester	
2M01	Cocoon
2M02	Pongee
2M03	Saffron
2M04	Tussah
2M05	Ceylon
2M06	Jasmine
2M07	Shale
2M08	Monsoon

### Slant

66" wide	
51% polyester	
49% recycled polyester	
22F01	Beech Nut
22F02	Chamois
22F03	Chartreuse
22F04	Pesto
22F05	Peacock
22F06	Neptune
22F07	Blueberry
22F08	Boysenberry
22F09	Magenta
22F10	Pumpkin
22F11	Cranberry
22F12	Silver Birch
22F13	Bluestone
22F14	Truffle
22F15	Shale

### Tailored

Assigned lead-time textile. <sup>A</sup>	
54" wide	
56% polyester	
44% recycled polyester	
23501	Studio White
23502	Sugar
23503	Tomato
23504	Orchid
23505	Boysenberry
23506	Chive
23507	Bluegrass
23508	Cobalt
23509	Cadet
23510	Fog
23511	Graphite
23512	Black
23513	Coffee

### Whisper

54" wide	
73% recycled polyester	
27% polyester	
1WS01	Sand Dollar
1WS02	Pebble
1WS03	Silver Birch
1WS04	Iceberg
1WS05	Silver Pine
1WS06	Carbon
1WS07	Cumin
1WS08	Adobe
1WS09	Strawberry
1WS10	Blush
1WS11	Eggplant
1WS12	Willow
1WS13	Sea Grass
1WS14	Pool
1WS15	Blueberry

## Price Category 2

### Code

66" wide	
100% Repreve recycled polyester	
1CD01	Linen
1CD02	Khaki
1CD03	Iceberg
1CD04	Zinc
1CD05	Blue Black

### ColorGuard

54" wide	
100% vinyl	
3P01	Grey
3P02	Navy
3P03	Spruce <sup>A</sup>
3P08	Blueberry <sup>A</sup>
3P12	Black Plum <sup>A</sup>
3P14	Black
3P19	Slate
3P31	Horizon Blue <sup>A</sup>
3P33	Pumice
3P54	Candy Apple <sup>A</sup>
3P72	Allspice <sup>A</sup>
3P96	Manzanita <sup>A</sup>
3P97	Fudge <sup>A</sup>
3PB2	Sea Grass <sup>A</sup>
3PB5	Vizcaya Palm <sup>A</sup>
3PB9	Neptune <sup>A</sup>
3PC7	Bucksuede <sup>A</sup>
3PD4	Otter <sup>A</sup>

<sup>A</sup> Assigned lead-time color.

# Proprietary Textile Colors — Workspaces

continued

## Price Category 2

continued

### Cord

66" wide	
51% antimony-free polyester	
49% polyester	
5101	Ivory
5102	White Ash
5103	Linen
5104	Bamboo
5105	Sepia
5106	Wicker
5107	Sesame
5108	Kiwi Green
5109	Bayou
5110	Shade
5111	Spring Wood
5112	Summer White

### Crepe

54" wide	
100% recycled polyester	
9201	Licorice
9203	Smoke
9207	Cherry
9209	Claret
9212	Raisin
9218	Aquamarine
9223	Cadet
9241	Beachglass
9243	Midnight
9244	Artichoke
9248	Warm White *
9249	Stone *
9250	Earth
9251	Fog *
9252	Slate Grey
9253	Yellow Dark
9254	Coral
9255	Blush Grey *
9256	Wild Berry
9257	Clover
9258	Caribbean
9259	Cerulean
9260	Brownstone

### Crepe continued

9261	Shale
9262	Graphite
9263	Tomato
9264	Green Apple

### Fish Net

55" wide	
100% recycled polyester	
22Q01	Oyster
22Q02	Stone
22Q03	Citrus
22Q04	Curry
22Q05	Chipotle
22Q06	Cherry
22Q07	Fuschia
22Q08	Claret
22Q09	Purple
22Q10	Clover
22Q11	Pesto
22Q12	Peacock
22Q13	Lagoon
22Q14	Twilight
22Q15	Bluestone
22Q16	Storm
22Q17	Black
22Q18	Cocoa

### Frost

66" wide	
100% recycled polyester	
5701	Bisque
5702	Abalone
5703	Porcelain
5704	Honey
5705	Iceberg
5706	Sage
5707	Reed
5708	Steam Grey
5709	Gunmetal
5710	Sable Grey

### Grosgrain

66" wide	
100% recycled polyester	
8401	Pearl *
8402	White Ash
8403	Warm Grey
8404	Khaki
8405	Oyster *
8406	Celadon
8408	Spa Blue
8409	Bud
8410	Kiwi Green
8411	Bayou
8412	Tin
8413	Iceberg *

\* Colors not available on Canvas Dock Mounted Screens, Locale® Workbase Screen, Public Office Landscape® Screen/Desk Top Divider, and Thrive® Personal Side Screen.

### Horizon

54" wide	
65% antimony-free polyester	
35% polyester	
4N01	Rye Grass
4N02	Sugar Pine
4N03	Silver Pine
4N04	White Ash
4N05	Spring Wood
4N06	Tamarack
4N07	Mushroom
4N08	Haystack
4N09	Oat Grass
4N10	Forest Moss
4N11	Hickory
4N12	Beech Nut
4N13	Pine Cone
4N14	Poplar
4N15	Elderberry

### Loom

54" wide	
100% polyester	
1LM01	Linen
1LM02	Brown Sugar and Spice
1LM03	Brick and Mortar
1LM04	Salt and Pepper
1LM05	Black
1LM06	Lemongrass
1LM07	Poppy
1LM08	Wild Berry
1LM09	Loden
1LM10	Jade
1LM11	Deep Sea

### Medley

54" wide	
100% polyester	
1HA01	Stone *
1HA02	Trail
1HA03	Charcoal
1HA04	Cinder
1HA05	Citrus
1HA06	Papaya
1HA07	Chutney
1HA08	Tundra
1HA09	Feather Grey *
1HA10	Chartreuse
1HA11	Loden
1HA12	Peacock
1HA13	Bayou *
1HA14	Blue Grotto
1HA15	Blueberry
1HA22	Khaki
1HA23	Pewter
1HA24	Yellow Oxide
1HA25	Vintage Rose
1HA26	Raspberry
1HA27	Acai Berry

\* Colors available on Exclave® Video-friendly Tackable Boards and Stowage Tackable Backdrop

\* Colors available on Exclave® Video-friendly Tackable Boards and Stowage Tackable Backdrop

# Proprietary Textile Colors — Workspaces

continued

## Price Category 2

continued

### Moiré

54" wide	
100% recycled polyester	
3A01	Concrete
3A02	Biscotti
3A03	Rattan
3A04	Chambray
3A05	Fern
3A08	Violet
3A09	Zin
3A10	Curry
3A11	Spice
3A12	Cork

### Rivet

54" wide	
100% recycled polyester	
1RV01	Twig
1RV02	Deep Clay
1RV03	Woodrose
1RV04	Otter
1RV05	Hemlock
1RV06	Olive
1RV07	Lagoon
1RV08	Deep Sea
1RV09	Charcoal
1RV10	Grey Brindle

### Tape

66" wide	
52% polypropylene	
48% recycled polyester	
4301	Pearl
4302	Oyster
4303	Wicker
4304	Reed
4306	Celadon
4307	Alabaster
4308	Bamboo
4309	Feather Grey
4310	Iceberg

### Twist

54" wide	
80% antimony-free polyester	
13% recycled polyester	
7% polyester	
8R05	Wicker
8R10	Poppy
8R14	Tin
8R15	Shale
8R16	Graphite
8R17	Birch
8R18	Sepia
8R22	Blueberry
8R23	Green Apple
8R26	Gunmetal
8R27	Cinder
8R28	Citrus
8R29	Pekoe
8R30	Tangerine
8R31	Red Plum
8R32	Wisteria
8R33	Forest
8R34	Jade Dark
8R35	Waterfall
8R36	Midnight Blue
8R37	arbon Dark

### Twist

For workspaces products only.	
54" wide	
80% antimony-free polyester	
13% recycled polyester	
7% polyester	
5S01	Pearl
5S02	Ivory
5S03	Oyster

### Well Suited

55" wide	
79% polyester	
21% recycled polyester	
22T01	Oyster
22T02	Raffia
22T03	Peppermint
22T04	Wild Berry
22T05	Spring Green
22T06	Mint
22T07	Periwinkle
22T08	Cool Grey
22T09	Citrus
22T10	Pumpkin
22T11	Red
22T12	Fuschia
22T13	Orchid
22T14	Chartreuse
22T15	Green Apple
22T16	Jade
22T17	Peacock
22T18	Blueberry
22T19	Bluestone
22T20	Mink

## Price Category 3

### Bento

54" wide	
100% antimony-free polyester	
7001	Frost
7002	Linen
7003	Khaki
7004	Truffle
7005	Grey Black
7006	Pumpkin
7007	Cranberry
7008	Everglade
7009	Cobalt

### Connection

66" wide	
100% antimony-free polyester	
1FB1	Oyster
1FB2	Linen
1FB3	Iceberg
1FB4	Silver Pine
1FB5	Apricot
1FB6	Cumin
1FB7	Green Apple
1FB8	Slate Blue
1FB9	Metal

# Proprietary Textile Colors — Workspaces

continued

## Price Category 3

continued

Current	
66" wide	
100% antimony-free polyester	
1FC1	Oyster
1FC2	Linen
1FC3	Iceberg
1FC4	Silver Pine
1FC5	Apricot
1FC6	Cumin
1FC7	Green Apple
1FC8	Slate Blue
1FC9	Metal

Glaze	
66" wide	
100% recycled polyester	
8Z01	Wicker
8Z02	Honey
8Z03	Porcelain
8Z04	Celadon
8Z06	Rye
8Z07	Frost
8Z08	Silver Birch

Ground Cloth®	
66" wide	
100% polyester	
4701	Vapor Grey
4721	Warm White *
4722	Fog *
4723	Straw *
4724	Red Orange *
4725	Wild Berry *
4726	Green Apple *
4727	Caribbean *
4728	Midnight *
4729	Cappuccino *

\* Colors available on Exclave®  
Video-friendly Tackable Boards  
and Stowage Tackable Backdrop

Kira 2	
54" wide	
100% recycled polyester	
5D11	Flaxen
5D12	Papyrus
5D13	Oasis
5D14	Incense
5D15	Ash
5D16	Falcon

Pins and Needles	
58" wide	
76% recycled polyester	
24% polyester	
22R01	Day and Night
22R02	Night and Day

Savannah	
66" wide	
76% recycled polyester	
24% polypropylene	
8L01	Pearl
8L02	Oyster
8L03	Wheat
8L04	Jute
8L05	Bamboo
8L06	Metal
8L07	Linen
8L08	Celadon
8L09	Moss
8L10	Frost
8L11	Shale
8L12	Pewter

Stitches	
54" wide	
54% polyester	
46% recycled polyester	
8U02	Rye
8U03	Khaki
8U04	Honey
8U05	Cattail
8U08	Cool Grey
8U09	Slate Blue
8U11	Evening Blue
8U12	Charcoal
8U13	Kiwi Green
8U16	Cocoa
8U17	Seed

Stitches	
For workspaces products only.	
54" wide	
54% polyester	
46% recycled polyester	
5Z01	White Ash

Strands	
66" wide	
100% recycled polyester	
8W01	Pebble
8W02	Porcelain
8W03	Taupe
8W04	Honey
8W05	Khaki
8W06	Rye
8W07	Wicker
8W08	Tin
8W09	Cool Grey

String Plaid	
54" wide	
100% recycled polyester	
22V01	Warm White on Khaki
22V02	Mint on Yellow Green
22V03	Mist on Blue Grey
22V04	Sky Blue on Red
22V05	Lime on Magenta
22V06	Bright Green on Green
22V07	Aqua Blue on Cerulean
22V08	Ivory on Black

# Proprietary Textile Colors — Workspaces

continued

## Price Category 4

<b>Glisten</b>	
66" wide	
84% polyester	
16% recycled polyester	
2X02	Rye
2X05	Iceberg
2X09	Pewter
2X10	Ash
<b>Loft</b>	
Assigned lead-time textile. <span style="border: 1px solid black; padding: 0 2px;">A</span>	
54" wide	
100% wool	
22L01	Heathered Light Green
22L02	Heathered Dark Green
22L03	Heathered Turquoise
22L04	Heathered Navy
22L05	Heathered Orange
22L06	Heathered Red
22L07	Heathered Tan *
22L08	Heathered Grey *
22L09	Heathered Blue *
22L10	Heathered Brown
22L11	Heathered Dark Grey
22L12	Heathered Denim

\* Colors available on Exclave®  
Video-friendly Tackable Boards  
and Stowage Tackable Backdrop

## Price Category 5

<b>Quilty</b>	
56" wide	
100% antimony-free polyester	
GreenShield	
6S03	Khaki
6S04	Straw
6S07	Brick
6S10	Mink
6S11	Green Apple
6S13	Indigo
6S14	Zinc
6S15	Slate
6S16	Beachwood
6S17	Paprika
6S18	Plum
6S19	Juniper
6S20	Grey Black
<b>Sironetta</b>	
66" wide	
100% recycled polyester	
6301	Acapella
6302	Sonata
6303	Interlude
6304	Legato
6308	Harmony
6309	Ensemble

<b>Hopsak</b>	
56" wide	
100% recycled polyester	
14A20	Black
14A22	Raw Umber Dark
14A26	Grey Blue Dark
14A30	Sepia Dark
14A38	Emerald Dark
14A39	Yellow Dark
14A40	Orange
14A41	Sienna
14A42	Olive Green Dark
14A43	Crimson
14A44	Crimson Dark Dark
14A45	Violet Dark
14A46	Pink Dark Dark
14A47	Ultramarine Dark
14A48	Cobalt Blue
14A49	Terra Cotta
14A50	Ochre Dark

# Customer's Own Material/Customer's Own Leather Order Information — Seating

## Packaging

Packaging varies according to individual product. A surcharge may be added for special packaging requests. Contact Customer Care for specific information.

## Customer's Own Material/Customer's Own Leather

### Program Overview

The Customer's Own Material (COM) and Customer's Own Leather (COL) program gives you the option of using textiles other than those listed. Herman Miller will test textiles for application to Herman Miller products and will process orders for those with approved COM/COL textiles only. COM/COL are assigned lead-time textiles.

Omni lists an overview of fabrics and leathers that have been tested and indicates whether or not they were approved for application to Herman Miller products.

Specific information on the terms and conditions, testing, approval, and ordering process for COM/COL is listed below. Questions about the COM/COL program and requests for assistance may be directed to your COM representative at:

(616) 654 3400

(866) 854 3048 EXT 6543400

### Customer's Own Material/Customer's Own Leather Warranty

Herman Miller does not warrant COM/COL textiles. COM/COL textiles are tested for application only; they are not tested for performance. The Herman Miller warranty does apply to the underlying products.

Suppliers of COM/COL textiles are responsible for color consistency within commercial tolerances, UV stability, and resistance to soiling and perspiration.

### Customer's Own Material/Customer's Own Leather Pricing

COM is a Category 1 fabric. There are no application charges for COM fabrics. COL is a Category 7 textile; refer to prices on specific products to determine the application charge.

Ordering and payment for COM/COL textile yardage are the responsibility of the customer and the textile supplier.

If desired, Herman Miller will purchase COM textiles directly from True Textiles, C.F. Stinson, Luna Textiles, Maharam, and Momentum Textiles to simplify ordering and shipment. For this service, refer to the Supplier Connection program.

## Textile Approval

1. Select a COM/COL textile and a Herman Miller product.
2. If your textile is not listed in Omni, obtain a test number from a COM representative at (616) 654 3400. You can also submit your request within Omni. Please have the following information ready before calling: textile name, number, pattern, roll width, and the product you will apply it to.

Additional yardage may be needed due to the unique characteristics of a textile. All package labels must include the words "COM test" or "COL test" and the assigned COM/COL test number.

3. Herman Miller will notify you of approval or disapproval within 4 days from receipt of the test yardage.

## Ordering Products with COM/COL

1. Refer to the specific products to determine the yardage required for COM/COL textiles.
2. If your textile is not listed in Omni, call a COM representative at (616) 654 3400 or (866) 854 3048 EXT 6543400. The representative will assign an identification number for your textile (ID#) and will verify yardage requirements for your order. Additional yardage may be needed due to the unique characteristics of a textile.
3. Enter your order on Order Manager in Omni.
4. Upon receipt of your purchase order, Herman Miller will send you a PO acknowledgment.
5. Arrangements must be made for the textiles to be shipped from the supplier to Herman Miller for application to the seating products. Textiles must be tagged with the assigned identification number and the roll yardage quantity. See Omni for shipping procedures and current shipping addresses or contact a COM representative at (616) 654 3400 or (866) 854 3048 EXT 6543400.

Products will be scheduled for production when COM/COL textiles are received at Herman Miller. Standard lead times in effect at that time will apply.

*Note: If textiles are to be purchased directly by Herman Miller through the Supplier Connection program, Herman Miller will handle the ordering and shipping process and will schedule your order for production upon receipt of your purchase order (dependent on textile availability). Refer to the Supplier Connection program for more information.*

# Customer's Own Material/Customer's Own Leather Order Information — Seating

continued

## Supplier Connection

### Program Overview

The Supplier Connection program is a service offered by Herman Miller to purchase approved COM textiles directly from True Textiles, C.F. Stinson, Luna Textiles, Maharam, and Momentum Textiles. When you select a textile through this program, Herman Miller will facilitate the ordering, scheduling, and shipment of the textile directly with the supplier.

Suppliers included in the Supplier Connection program keep an active inventory of textiles that are pre-approved for application to Herman Miller products. Pre-approval applies only to the suitability of a textile for manufacturing and application to a Herman Miller product. Omni provides an overview of fabrics that have been tested and indicates whether or not they were approved for application to Herman Miller products.

Specific information on the terms and conditions, testing, approval, and ordering process for the Supplier Connection program is listed below. Questions and requests for assistance may be directed to your COM representative at:

(616) 654 3400

(866) 854 3048 EXT 6543400

### Supplier Connection Warranty

Textiles purchased by Herman Miller through the Supplier Connection program are COM and are not warranted by Herman Miller. COM textiles are tested for application only; they are not tested for performance. The Herman Miller warranty does apply to the underlying products.

Suppliers of COM textiles are responsible for color consistency within commercial tolerances, UV stability, and resistance to soiling and perspiration.

### Supplier Connection Pricing

Textiles purchased by Herman Miller through the Supplier Connection program are COM. COM is a Category 1 fabric. There are no application charges for COM fabrics.

Payment for textiles purchased by Herman Miller through the Supplier Connection program is the responsibility of the customer or dealer. Herman Miller will invoice the order at the supplier's prices published at the time of the order.

### Textile Approval

1. Refer to Omni to identify the approval status of the textile. If your textile is not listed, contact the COM Department to request testing for application to Herman Miller products.
2. Herman Miller will notify you of approval or disapproval in approximately 4 days from receipt of the test yardage. If the textile is approved, it will be assigned a COM identification number.

### Ordering Products with Supplier Connection COM

1. Identify and include the following information on your purchase order:
  - Product number and option
  - Herman Miller's COM identification number
2. Enter your order on Order Manager in Omni.
3. Upon receipt of the purchase order, Herman Miller will process your order and send you a PO acknowledgment. Herman Miller will determine the yardage required to produce your product and will order and schedule for delivery the required textile. Standard lead times in effect at the time the textile is allocated at the supplier will apply to products ordered through this program.



# Proprietary Textiles Application Chart — Seating

• Available

[A] Assigned lead-time textile.

See following page for exception notes.

[N] Non-woven textile.

	Aeron® Chairs	Mirra® 2 Chairs/Stools	Celle® Chairs/Stools	Embody® Chairs	Sayl® Work Chairs/Stools	Sayl Side Chairs	Setu® Chairs/Stools	Setu Lounge Chair/Ottoman	Verus™ Work Chairs/Stools Back	Verus Work Chairs/Stools Seat	Verus Side Chairs Back	Verus Side Chairs Seat	Ergon 3® Chairs	Equa 2 Fully Upholstered Chairs/Stools	Equa 2 Split-Pad Upholstered Chairs/Stools	Aside® Chairs	Caper® Chairs/Stools	Celeste™ Seating	Keyn Chair Group	Locale® Bench Cushion	Public Office Landscape® Back	Public Office Landscape Seat	Plex™ Lounge Furniture	Swoop™ Lounge Seating - Fully Upholstered	Swoop Lounge Seating - Plywood	Eames Tandem Sling Seating	Cushion Tops	Workspaces	
<b>Price Category 1</b>																													
COM Customer's Own Material [A]			14		1	1							1	1	1	1		1	1	1				1	1	1	1	1	1
231_ 8Z Pellicle®	•																												
1A7_ AireWeave™ 2		•																											
3P_ ColorGuard [N]			15		21	22	•	•	•	•	•	•	2		3	8		•	•	•				•	•	6	•	•	
8T_ Crossing			•				•	•					•	•	•	•				•				•	•		•	•	
6V_ Flexnet™																	•												
95_ Gem			14				•	•					•	•	•	•				•			•	•			•	•	
65_ Interweave									•																				
4W_ Lyris 2™								•	•																				
1MN_ Monologue			14		21	22	•	•		•	•	•	•					•	•	•			•	•	•	•	•	•	
3DK_ Stretch Knit [A]					21																								
235_ Tailored [A]			•		•	•	•		•	•	•	•						•	•				•	•			•	•	
1WS_ Whisper			14		21	•	•	•		•	•	•	•	•	•	•		•	•	•			•	•	•	•	•	•	
<b>Price Category 2</b>																													
92_ Crepe			•		•	•	•	•	•	•	•	•	•	•	•	•		•	•	•			•	•	•	•	•	•	•
22Q_ Fish Net			•		•	•	•			•	•	•	•	•	•	•		•	•				•	•	•			•	•
1LM_ Loom			14		•	•			•	•	•	•								•	•				•		•	•	
1MV_ Marvel					21	•			•	•	•	•						•									•	•	
1HA_ Medley			14	•	•	22			•	•	•	•	•	•	•	•		•	•	•			•	•	•		•	•	
3A_ Moiré			14	•	•	•	•		•	•	•	•	•	•	•	•		•	•			•	•	•			•	•	
30_ Rhythm			•	23	•	•			•	•	•	•			•	•		•	•	•			•	•	•		•	•	
1RV_ Rivet			14	•	21	22			•	•	•	•			•	•		•	•	•			•	•	•	•	•	•	
8R_ Twist			•		•	•	•	•	•	•	•	•			•	•		•	•				•	•	•		•	•	
22T_ Well Suited														•	8								•		23		•	•	
<b>Price Category 3</b>																													
70_ Bento					•	•	•	•		•			2	•	•	8		•											•
8M_ Latitude™		23			•	•									3									•	•				
22R_ Pins and Needles			14		•	•	•		•					•				•	•				•	•	•		•	•	
8U_ Stitches			•		•	•	•	•		•			•	•	•	•		•	•	•			•	•	•		•	•	
22V_ String Plaid			14		•	•			•	•	•				•			•	•	•			•	•	•		•	•	
<b>Price Category 4</b>																													
7Y_ Bingo [N]							•	•	•	•	•	•	2		3	8		•	•	•								•	
1DL_ Dialogue																					•								
213_ Mercer			14	•	•	22			•	•	•							•	•			•	•	•			•	•	
1A9_ Network																					•								
6J_ Plateau													•	•	•	•												•	
6S_ Quilty			14		•	•			•	•	•	•						•	•	•				•			•	•	
8Y_ Spools			14		21	•	•	•		•	•	•	•	•	•	•		•	•	•				•			•	•	
22P_ Strata					21	22	•		•	•	•	•				•		•	•	•			•	•	•		•	•	
<b>Price Category 5</b>																													
14A_ Hopsak			14		•	22	•	•	•	•	•	•	•	•	•	•		•	•	•			•	•	•	•	•	•	•
22N_ Noble (22H_) [A]			14		•	25	•		•	•	•	•	•	3	8			•	•	•			•	•	•		•	•	
<b>Price Category 6</b>																													
35_ Balance			•																										
<b>Price Category 7</b>																													
COL Customer's Own Leather [A]	1		14										1	1	1	8												1	
<b>Price Category 8</b>																													
No fabrics available at this time																													
<b>Price Category 9</b>																													
21_ Leather	23		14											•	•	8				4						•		•	

continued on next page

# Proprietary Textiles Application Chart — Seating

continued

• Available

[A] Assigned lead-time textile.

See below for exception notes.

[N] Non-woven textile.

## Fire-Retardant Chairs/Fabrics

	Mirra® 2 Chairs/Stools with Butterfly Back	Celle® Chairs/Stools	Embody® Chairs	Sayl® Work Chairs/Stools	Sayl Side Chairs	Setu® Chairs/Stools	Setu Lounge Chair/Ottoman	Ergon 3® Chairs	Equa 2® Fully Upholstered Chairs/Stools	Equa 2 Split-Pad Upholstered Chairs/Stools	Aside® Chairs	Caper® Chairs/Stools	Celeste™ Seating	Plex™ Lounge Furniture	Swoop™ Lounge Seating - Fully Upholstered	Fames® Tandem Sling Seating
<b>Price Category 1</b>																
COM Customers Own Material [A]							1	1	1	1		1				
1A7__ AireWeave™ 2	•															
3P__ ColorGuard [N]		15	24	22			2		3	8					•	6
8T__ Crossing		14				•	•	•	•	•			•		•	
6V__ Flexnet™												•				
95__ Gem		14				•	•	•	•	•			•	•	•	
4W__ Lyris 2™					18	•										
235__ Tailored [A]	•					•							•	•		
<b>Price Category 2</b>																
92__ Crepe		14	•	•				•	•	•		•	•	•		
22Q__ Fish Net		•	•	•	•									•		
3A__ Moiré		14	•	•	•	•	•	•	•	•			•			
30__ Rhythm		14	16	24						8					•	
8R__ Twist		14	•	•	•	•	•			8			•	•	•	
<b>Price Category 3</b>																
70__ Bento				•	•	•	•	2	•	8					•	
8M__ Latitude™		•	•	•												
22R__ Pins and Needles				•	•	•										
8U__ Stitches		14	•	•	•	•	•	•	•	•			•	•	•	
22V__ String Plaid				•									•			
<b>Price Category 4</b>																
6J__ Plateau										•						
6S__ Quilty		14	•	•											•	
<b>Price Category 5</b>																
14A__ Hopsak		14	•			•		•	•	•				•	•	
<b>Price Category 6</b>																
35__ Balance			17													
<b>Price Category 9</b>																
21__ Leather		14								8						

All foam and Proprietary Textiles on HermanMiller seating comply with California TB 117-2013.

Application Note: Herman Miller cannot guarantee material/pattern alignment in adjacent products. For example, a fabric's pattern may not align from one pedestal cushion top to the next, or from one chair to another.

- 1 Refer to price book appendices and Omni for COM/COL information.
- 2 Available on all Ergon 3 chairs except for fabric back (FB) option.
- 3 Available on A- and B-size Equa 2 split-pad upholstered chairs.
- 4 See specific products for information on specifying leather in combination with fabric.
- 6 Only available in 3P02 Navy, 3P03 Spruce, 3P14 Black, 3P17 Burgundy, 3P19 Slate, and 3PC7 Bucksuede.
- 8 Only available on nonupholstered outer back option (PB).
- 14 Available on Celle UC (upholstered seat) and HC (upholstered seat with protective edge) Chairs.
- 15 Available only on Celle HC (upholstered seat with protective edge) Chairs.
- 16 Only available in 3014 Black.
- 17 Only available in 3512 Carbon and 3513 Black.
- 18 Only available in 4W26 Slate Grey, 4W30 Java, and 4W31 Graphite.
- 21 Not available on Sayl upholstered back work chairs.
- 22 Not available on Sayl side chairs with upholstered backs.
- 23 Available in select colors. Refer to "Proprietary Textile Colors-Seating" for color offering.
- 24 Not available on Sayl upholstered High-Back Work Chairs.
- 25 Not available on Sayl side chairs with upholstered backs. Available in select colors. Refer to "Proprietary Textile Colors-Seating" for color offering.

# Proprietary Textile Colors — Seating

## Price Category 1

**Customer's Own Material**  
See Order Information in  
Appendices.  
Assigned lead-time textile. **A**

**8Z Pellicle®**  
For New Aeron® Chairs  
56% elastomeric  
44% polyester  
23101 Mineral  
23102 Carbon  
23103 Graphite

**AireWeave™ 2**  
For Mirra® 2 Chairs  
67% elastomeric  
33% antimony-free polyester  
1A701 Alpine  
1A702 Slate Grey  
1A703 Graphite  
1A704 Lime Green  
1A705 Cappuccino  
1A706 Urban Orange  
1A707 Dark Turquoise  
1A708 Twilight

**ColorGuard**  
54" wide  
100% vinyl  
3P01 Grey  
3P02 Navy \*  
3P03 Spruce \* **A**  
3P08 Blueberry **A**  
3P12 Black Plum **A**  
3P14 Black \*  
3P19 Slate \*  
3P31 Horizon Blue **A**  
3P33 Pumice  
3P54 Candy Apple **A**  
3P72 Allspice **A**  
3P96 Manzanita **A**  
3P97 Fudge **A**  
3PB2 Sea Grass **A**  
3PB5 Vizcaya Palm **A**  
3PB9 Neptune **A**  
3PC7 Bucksuede \* **A**  
3PD4 Otter **A**

\* Colors available on Eames®  
Tandem Sling Seating.  
**A** Assigned lead-time color.

**Crossing**  
54" wide  
86% antimony-free polyester  
14% polyester  
8T03 Wicker  
8T04 Porcelain  
8T05 Warm Grey  
8T06 Sepia  
8T07 Pumpkin  
8T08 Copper  
8T09 Cranberry  
8T10 Tomato  
8T11 Mulberry  
8T12 Plum  
8T13 Green Apple  
8T14 Loden  
8T15 Spruce  
8T16 Periwinkle  
8T17 Cerulean  
8T18 Indigo  
8T19 Shale  
8T20 Brownstone  
8T21 Bark  
8T22 Tin  
8T23 Graphite  
8T24 Black

**Flexnet™**  
For Caper® Chairs  
69% elastomeric  
31% polyester  
6V01 Black  
6V02 Silver Grey

**Gem**  
54" wide  
100% antimony-free polyester  
9501 Sesame  
9502 Tangerine  
9503 Red  
9504 Red Violet  
9505 Mulberry  
9506 Java  
9507 Twilight  
9508 Bayou  
9509 Iris  
9510 Berry Blue  
9511 Aqua Green  
9512 Green Apple  
9513 Spruce  
9514 Black  
9515 Slate Grey  
9516 Fog

**Interweave**  
For Verus™ Chairs  
71% elastomeric  
29% polyester  
6504 Pewter  
6505 Charcoal  
6506 Black

**Lyris 2™**  
For Setu® Chairs  
74% elastomeric  
26% polyester  
4W21 Alpine  
4W22 Mango  
4W23 Chartreuse  
4W25 Berry Blue  
4W26 Slate Grey  
4W28 Chino  
4W29 Rattan  
4W30 Java  
4W31 Graphite

Price category 1 continued on  
next page

# Proprietary Textile Colors — Seating

continued

## Price Category 1

continued

Monologue	
54" wide	
56% recycled polyester	
44% polyester	
1MN01	Linen
1MN02	Alabaster
1MN03	Truffle
1MN04	Folkstone
1MN05	Silver Pine
1MN06	Slate
1MN07	Seed
1MN08	Yellow Oxide
1MN09	Persimmon
1MN10	Tundra
1MN11	Meadow
1MN12	Blue Sky
1MN13	Blue Spruce
1MN14	Deep Sea

Stretch Knit	
Assigned lead-time textile. <span style="border: 1px solid black; padding: 0 2px;">A</span>	
Available only on Sayl®	
Suspension Back Work Chairs	
97% polyester, 3% spandex	
3DK01	Fog
3DK02	Slate Grey
3DK03	Java
3DK04	Black
3DK05	Red
3DK06	Green Apple
3DK07	Berry Blue

Tailored	
Assigned lead-time textile. <span style="border: 1px solid black; padding: 0 2px;">A</span>	
54" wide	
56% polyester	
44% recycled polyester	
23501	Studio White
23502	Sugar
23503	Tomato
23504	Orchid
23505	Boysenberry
23506	Chive
23507	Bluegrass
23508	Cobalt
23509	Cadet
23510	Fog
23511	Graphite
23512	Black
23513	Coffee

Whisper	
54" wide	
73% recycled polyester	
27% polyester	
1WS01	Sand Dollar
1WS02	Pebble
1WS03	Silver Birch
1WS04	Iceberg
1WS05	Silver Pine
1WS06	Carbon
1WS07	Cumin
1WS08	Adobe
1WS09	Strawberry
1WS10	Blush
1WS11	Eggplant
1WS12	Willow
1WS13	Sea Grass
1WS14	Pool
1WS15	Blueberry

## Price Category 2

Crepe	
54" wide	
100% recycled polyester	
9201	Licorice
9203	Smoke
9207	Cherry
9209	Claret
9212	Raisin
9218	Aquamarine
9223	Cadet
9241	Beachglass
9243	Midnight
9244	Artichoke
9248	Warm White
9249	Stone
9250	Earth
9251	Fog
9252	Slate Grey
9253	Yellow Dark
9254	Coral
9255	Blush Grey
9256	Wild Berry
9257	Clover
9258	Caribbean
9259	Cerulean
9260	Brownstone
9261	Shale
9262	Graphite
9263	Tomato
9264	Green Apple

Fish Net	
55" wide	
100% recycled polyester	
22Q01	Oyster
22Q02	Stone
22Q03	Citrus
22Q04	Curry
22Q05	Chipotle
22Q06	Cherry
22Q07	Fuschia
22Q08	Claret
22Q09	Purple
22Q10	Clover
22Q11	Pesto
22Q12	Peacock
22Q13	Lagoon
22Q14	Twilight
22Q15	Bluestone
22Q16	Storm
22Q17	Black
22Q18	Cocoa

Loom	
54" wide	
100% polyester	
1LM01	Linen
1LM02	Brown Sugar and Spice
1LM03	Brick and Mortar
1LM04	Salt and Pepper
1LM05	Black
1LM06	Lemongrass
1LM07	Poppy
1LM08	Wild Berry
1LM09	Loden
1LM10	Jade
1LM11	Deep Sea

Price category 2 continued on next page

# Proprietary Textile Colors — Seating

continued

## Price Category 2

continued

Marvel	
54" wide	
100% pvc-free polyurethane	
1MV01	Summer White
1MV02	Sand Dollar
1MV03	Espresso
1MV04	Folkstone Grey
1MV05	Graphite
1MV06	Onyx
1MV07	Polar Blue
1MV08	Blush Grey
1MV09	Woodrose
1MV10	Citrus
1MV11	Adobe
1MV12	Red
1MV13	Kiwi Green
1MV14	Pine
1MV15	Teal Green
1MV16	Twilight

Medley	
54" wide	
100% polyester	
1HA01	Stone
1HA02	Trail
1HA03	Charcoal
1HA04	Cinder
1HA05	Citrus
1HA06	Papaya
1HA07	Chutney
1HA08	Tundra
1HA09	Feather Grey
1HA10	Chartreuse
1HA11	Loden
1HA12	Peacock
1HA13	Bayou
1HA14	Blue Grotto
1HA15	Blueberry
1HA22	Khaki
1HA23	Pewter
1HA24	Yellow Oxide
1HA25	Vintage Rose
1HA26	Raspberry
1HA27	Acai Berry

Moiré	
54" wide	
100% recycled polyester	
3A01	Concrete
3A02	Biscotti
3A03	Rattan
3A04	Chambray
3A05	Fern
3A08	Violet
3A09	Zin
3A10	Curry
3A11	Spice
3A12	Cork

Rhythm	
54" wide	
100% polyester	
3001	Kiwi Green *
3002	Green Apple
3003	Peacock
3004	Bayou *
3005	Berry Blue
3006	Iris
3007	Twilight
3008	Pumpkin *
3009	Poppy *
3010	Molasses
3011	Mulberry
3012	Khaki *
3013	Mink
3014	Black
3015	Charcoal

\* Colors not available on Embody® Chair.

Rivet	
54" wide	
100% recycled polyester	
1RV01	Twig
1RV02	Deep Clay
1RV03	Woodrose
1RV04	Otter
1RV05	Hemlock
1RV06	Olive
1RV07	Lagoon
1RV08	Deep Sea
1RV09	Charcoal
1RV10	Grey Brindle

Twist	
54" wide	
80% antimony-free polyester	
13% recycled polyester	
7% polyester	
8R05	Wicker
8R10	Poppy
8R14	Tin
8R15	Shale
8R16	Graphite
8R17	Birch
8R18	Sepia
8R22	Blueberry
8R23	Green Apple
8R26	Gunmetal
8R27	Cinder
8R28	Citrus
8R29	Pekoe
8R30	Tangerine
8R31	Red Plum
8R32	Wisteria
8R33	Forest
8R34	Jade Dark
8R35	Waterfall
8R36	Midnight Blue
8R37	Carbon Dark

Price category 2 continued on next page

# Proprietary Textile Colors — Seating

continued

## Price Category 2

continued

Well Suited	
55" wide	
79% polyester	
21% recycled polyester	
22T01	Oyster *
22T02	Raffia *
22T03	Peppermint *
22T04	Wild Berry *
22T05	Spring Green *
22T06	Mint *
22T07	Periwinkle *
22T08	Cool Grey *
22T09	Citrus *
22T10	Pumpkin
22T11	Red
22T12	Fuschia
22T13	Orchid
22T14	Chartreuse *
22T15	Green Apple
22T16	Jade
22T17	Peacock
22T18	Blueberry
22T19	Bluestone *
22T20	Mink

\* Colors not available on Swoop™ Plywood Lounge Seating.

## Price Category 3

Bento	
54" wide	
100% antimony-free polyester	
7001	Frost
7002	Linen
7003	Khaki
7004	Truffle
7005	Grey Black
7006	Pumpkin
7007	Cranberry
7008	Everglade
7009	Cobalt

Latitude™	
61" wide	
100% polyester	
8M01	Graphite
8M02	Shadow
8M10	Alpine
8M17	Black
8M21	Slate Grey
8M22	Lime Green
8M23	French Press
8M24	Urban Orange
8M25	Dark Turquoise
8M26	Twilight

Latitude	
Colors for Mirra 2 Chairs	
100% polyester	
8M10	Alpine
8M17	Black
8M21	Slate Grey
8M22	Lime Green
8M23	French Press
8M24	Urban Orange
8M25	Dark Turquoise
8M26	Twilight

Pins and Needles	
58" wide	
76% recycled polyester	
24% polyester	
22R01	Day and Night
22R02	Night and Day

Stitches	
54" wide	
54% polyester	
46% recycled polyester	
8U02	Rye
8U03	Khaki
8U04	Honey
8U05	Cattail
8U08	Cool Grey
8U09	Slate Blue
8U11	Evening Blue
8U12	Charcoal
8U13	Kiwi Green
8U16	Cocoa
8U17	Seed

String Plaid	
54" wide	
100% recycled polyester	
22V01	Warm White on Khaki
22V02	Mint on Yellow Green
22V03	Mist on Blue Grey
22V04	Sky Blue on Red
22V05	Lime on Magenta
22V06	Bright Green on Green
22V07	Aqua Blue on Cerulean
22V08	Ivory on Black

## Price Category 4

Bingo	
54" wide	
100% PVC-free polyurethane	
Resilience® finish	
7Y01	Oyster
7Y02	Natural
7Y03	Cashew
7Y05	Rattan
7Y06	Root
7Y07	Woodland
7Y10	Allspice
7Y11	Canyon
7Y17	Seed
7Y18	Mushroom
7Y19	Blue Grey
7Y21	Black
7Y22	Mint
7Y23	Seaport
7Y24	Evening Blue
7Y26	Kiwi Green
7Y27	Celadon
7Y29	Pesto

Price category 4 continued on next page

# Proprietary Textile Colors — Seating

continued

## Price Category 4

continued

### Dialogue

For Public Office Landscape®  
Sectional Back/Social Chair Back  
knit to size

100% polyester

1DL01 Light Brindle

1DL02 Dark Brindle

### Mercer

54" wide

50% solution dyed recycled nylon

50% solution dyed nylon

BLOCKaide

21301 Stone

21303 Cayenne

21305 Pesto

21306 Teal Blue

21307 Ultramarine

21310 Charcoal

### Network

For Public Office Landscape®  
Sectional Back/Social Chair Back  
knit to size

100% polyester

1A901 Warm White

1A902 Fog

1A903 Red

1A904 Wildberry

1A905 Green Apple

1A906 Twilight

1A907 Graphite

### Plateau

#### Perspectives® Collection

knit to size

100% polyester

6J01 Feather Grey

6J02 Trail

6J06 Twig

6J08 Sagebrush

6J09 Winter Berry

6J10 Thunder

6J11 Blueberry

6J12 Rosemary

6J14 Black

### Quilty

56" wide

100% antimony-free polyester

GreenShield

6S03 Khaki

6S04 Straw

6S07 Brick

6S10 Mink

6S11 Green Apple

6S13 Indigo

6S14 Zinc

6S15 Slate

6S16 Beachwood

6S17 Paprika

6S18 Plum

6S19 Juniper

6S20 Grey Black

### Spools

54" wide

51% recycled polyester

49% polyester

Crypton® Green

8Y03 Trail

8Y05 Copper

8Y08 Bluegrass

8Y09 Lagoon

8Y11 Beachglass

8Y12 Marsh

8Y13 Bud

### Strata

54" wide

50% solution dyed recycled nylon

50% solution dyed nylon

BLOCKaide

22P04 Pesto

22P05 Peacock

22P06 Blue Jay

22P07 Blueberry

22P09 Mango

22P10 Paprika

22P12 Wheat

22P13 Brownstone

22P14 Bayou

## Price Category 5

### Hopsak

56" wide

100% recycled polyester

14A20 Black

14A22 Raw Umber Dark

14A26 Grey Blue Dark

14A30 Sepia Dark

14A38 Emerald Dark

14A39 Yellow Dark

14A40 Orange

14A41 Sienna

14A42 Olive Green Dark

14A43 Crimson

14A44 Crimson Dark Dark

14A45 Violet Dark

14A46 Pink Dark Dark

14A47 Ultramarine Dark

14A48 Cobalt Blue

14A49 Terra Cotta

14A50 Ochre Dark

### Noble

Assigned lead-time textile. <sup>A</sup>

54" wide

100% wool

22N02 Chipotle \*

22N04 Cherry \*

22N07 Cadet \*

22N08 Berry Blue \*

22N09 Peacock \*

22N11 Pesto \*

22N12 Blue Grey Mix \*

22H15 Heathered Black \*\*

22H16 Heathered Grey \*\*

22H17 Heathered Twilight \*\*

22H18 Heathered Rye Grass \*\*

22N19 Lemongrass Mix \*

22H20 Heathered Red \*\*

22H21 Heathered Wild Berry \*\*

22N22 Pesto Mix \*

22N23 Lagoon Mix \*

\* Colors not available on Sayl® Side Chairs.

\*\* Colors not available on Sayl Side Chairs Back.

# Proprietary Textile Colors — Seating

continued

Appendix: Proprietary Textile Colors | Seating

## Price Category 6

Balance	
For Embody® chairs	
100% polyester	
3506	Green Apple
3507	Blue Moon
3509	Berry Blue
3510	Iris
3512	Carbon
3513	Black

## Price Category 7

**Customer's Own Leather**  
See Order Information in Appendices. Assigned lead-time textile. [A](#)

## Price Category 8

No fabrics available at this time.

## Price Category 9

Leather	
approx. 50 sq. ft. per hide	
100% leather	
2101	Ivory
2109	Black *
2110	Smoke
2111	Graphite
2112	Khaki
2113	Rattan
2114	Truffle
2115	Alpine
2116	Haze
2117	Sable Grey
2118	Dark Mineral **
2119	Dark Carbon ***
2120	Cranberry
2121	Deep Sea

\* Armpad color available on Aeron® Chair, Graphite.

\*\* Armpad color available on Aeron Chair, Mineral.

\*\*\* Armpad color available on Aeron Chair, Carbon.





For more information about our products and services or to see a list of dealers, please visit us at [HermanMiller.com](http://HermanMiller.com) or call (800) 851 1196.

© 2018 Herman Miller, Inc., Zeeland, Michigan

® **HermanMiller**, 3D Intelligent, AO, Action Office, Aeron, ArcSpan, Aside, Avall, Avive, Bubble Lamps, Canvas Office Landscape, Caper, Celle, Co/Struc, Daisyone, Distil, Eames, Eco-Dematerialized, Embody, Envelop, Equa 2, Ergon 3, Ethospace, Exclave, Fine-Tune, FlexFront, Flo, Formcoat, Formwork, Ground Cloth, Herman Miller for the Home, Herman Miller for Healthcare, Intersect, Kinemat, Lapjack, Layout Studio, Lifework, Limerick, Live Unframed, Living Office, Locale, Maharam, Meridian, Mirra, Passage, Pellicle, Perspectives, PostureFit, Public Office Landscape, Resolve, Rodney, Sayl, Setu, Thrive, Tu, Wishbone, and Y-Tower are among the registered trademarks of Herman Miller, Inc., and its owned subsidiaries.

™ 8Z Pellicle, About Face, AireWeave, Albert, Backfit, Bubbletack, Burdick Group, Butterfly Back, Celeste, Cellular Suspension, Clam, Compass, Connect, Cubert, DOT, Duracare, Durawrap, Eames Soft Pad, EnhancedAccess, Everywhere, Flex-Edge, Flute, Harmonic, Herman Miller Select, Hopsak 2, Intent, Iota, Jaw, Keyless Entry, Keyn Chair Group by Herman Miller, Latitude, Locale, Logic Mini, Logic Power Access Solutions, Live OS, Loop, Lyris, Lyris 2, Made-to-Measure Storage, Metaform Portfolio, Mora, Motia, Multiscrim, Nelson, Pari, Pixelated Support, Plex, PostureFit SL, Prospect, Q, Renew, Sense, Soft Pad, Stackable, Stackable Storage, Striad, Swoop, Tone, TriFlex, Twist, Ubi, Verus and Wireframe are among the trademarks of Herman Miller, Inc., and its owned subsidiaries.

SM Herman Miller Options is among the service marks of Herman Miller, Inc.

Alexander Girard® is a registered trademark of The Alexander Girard Estate.

Chemsur® is a registered trademark of Wilsonart International.

Corian® is a registered trademark of E. I. du Pont de Nemours and Company Corporation.

Crypton® is a registered trademark of Crypton, Inc.

DACRON® is a registered trademark of INVISTA S.a r.l.

Edelman® Leather is a registered trademark of Edelman Leather, Inc.

FENIX NTM® is a registered trademark of Arpa Industriale S.p.A.

FLEXNET™ is a trademark of Milliken & Company.

Floor Saver Glide® is a registered trademark of Carpin Manufacturing, Inc.

Geiger® is a registered trademark, and Bumper™, Saiba™, and Ward Bennett™ are trademarks, of Geiger International.

Goetz™ is a trademark of Mark W. Goetz.

Hang-It-All® is a registered trademark of Lucia Eames Demetrios, d.b.a. Eames Office.

Holophane® is a registered trademark of Holophane.

Ingeo™ is a trademark of Cargill Dow LLC.

iPad® is a registered trademark of Apple, Inc.

LifeSize® is a registered trademark of LifeSize Communications, Inc.

Magis®, Bombo®, and Me Too® are registered trademarks of Magis S.p.A.

Microsoft® and Natural® Keyboard are registered trademarks of Microsoft Corporation.

Noguchi® and the Noguchi table configuration (trade dress) are registered trademarks, and Rudder Table™ is a trademark, of The Isamu Noguchi Foundation and Garden Museum.

Place Textiles® is a registered trademark of Place Textiles.

SuperSeat™ is a trademark of Dahti Seating, a division of ITW.