



GSA prices effective April 2, 2018
(based on February 6, 2017, commercial price list)
Published April 2018

Workspaces

Public Office Landscape®

General Services Administration Federal Supply Service Authorized Federal Supply Schedule Price List

Online access to contract ordering information, terms and conditions, up-to-date pricing, and the option to create an electronic delivery order is available through GSA Advantage!, a menu-driven database system. The Internet address for GSA Advantage! is www.gsaadvantage.gov.

Office Furniture
FSC Group 71, Part 1
Contract Number: GS-03F-036DA
Contract Period: December 21, 2015—December 20, 2020

Herman Miller, Inc.
855 East Main Avenue
Zeeland, Michigan 49464
(616) 654 3000 Phone
(616) 654 8278 Fax
www.HermanMiller.com/government

Business Size: Large

Contract Information

1a. Special Item Numbers (SIN)

SIN 71-1
Packaged Offices

SIN 711-1
Furniture Systems

SIN 711-2
Computer Furniture

SIN 711-3
Filing and Storage Cabinets

SIN 711-11
Tables and Accessories

SIN 711-16
Upholstered Seating

SIN 711-18
Multi-Purpose Seating

SIN 711-91
Project Management

Services under this SIN may be used only in conjunction with the purchase of new furniture. Please contact your local Herman Miller representative to discuss the available labor categories (listed below). The hourly rates listed are "Not To Exceed" or "NTE" values.

Furniture Project Manager: \$64.75 per hour
Furniture Project Coordinator: \$49.00 per hour
Build-Out Project Manager: \$80.00 per hour

SIN 711-93
Reconfiguration and Relocation Services

Reconfiguration and Relocation Services will be provided by Herman Miller, Inc., or its participating dealer based on a fee not to exceed \$55 per hour, which applies to services totaling \$150,000 (per SIN) and below only. Services above \$150,000 shall be negotiated on a case-by-case basis. This SIN may only be used with the purchase of new product under SIN 711-1.

See * Additional Notes for Installation & Reconfiguration and Relocation Services.

SIN 711-94
Design/Layout

Design service will be provided by Herman Miller, Inc., or its participating dealer based on a fee not to exceed \$65 per hour.

SIN 711-95

Installation Services

Installation Services will be provided by Herman Miller, Inc., or its participating dealer based on a fee not to exceed \$55 per hour (\$82.50 per hour for after-hours Installation), which applies to services totaling \$150,000 (per SIN) and below only. Services above \$150,000 shall be negotiated on a case-by-case basis.

See * Additional Notes for Installation & Reconfiguration and Relocation Services.

* Additional Notes for Installation & Reconfiguration and Relocation Services:

FOB Destination (Drop Ship): Price includes product delivery to the site, brought to the tailgate of the truck. The purchaser is responsible for unloading.

Prices effective up to the maximum order by SIN only. Above the MO, pricing shall be negotiated on a case-by-case basis between the client and local dealer.

Standard Services are Subject to the Following Conditions:

Installation will be performed during normal weekday working hours.

Adequate facilities for delivery, unloading, moving and staging/ storing the product during the installation process shall be provided.

Service work will not be hindered by other trades.

Electric, heat, and adequate elevator service will be furnished without charge.

The immediate installation area shall be complete and free of debris including the carpet/flooring before installation commences.

Any work requiring a licensed electrician is the responsibility of the buyer.

Additional Charges May Apply For:

Major Metro Markets and any non-ground floor installation.

Major Metro Markets include large population centers and urban environments.

Installation in a clinical/medical environment.

Special restrictions or limits established by local laws, ordinances or the directions of the buyer, including but not limited to restrictions on transportations of materials, street access to the job site and/or dock facilities.

Installations outside of a 50 mile radius of the servicing dealer.

Local Prevailing Wage and/or Union Labor Rates.

Any additional charges shall be quoted by the dealer and approved by the buyer prior to performance of the work.

SIN 711-96

Leasing

Contact Herman Miller participating government dealer for current leasing information.

SIN 711-99

New Product Introductions

Contract Information

continued

1b. Lowest Priced Model

SIN 711-1:	G9999.B	\$7
SIN 711-2:	6-5-D	\$35
SIN 711-3:	9M10018	\$14
SIN 711-11:	DT9A.	\$36
SIN 711-16:	OA401	\$41
SIN 711-18:	AS90598	\$46
SIN 711-99:	R1366	\$27

1c. Not applicable

2. Maximum Order

SIN 711-1, SIN 711-2
\$500,000 net product value

SIN 711-3, SIN 711-11
\$300,000 net product value

SIN 711-16, SIN 711-18
\$200,000 net product value

SIN 711-93
\$150,000

SIN 711-94
\$150,000

SIN 711-95
\$150,000

SIN 711-96
\$500,000 net product value

SIN 711-99
\$50,000 net product value

3. Minimum Order

\$100 net

4. Geographic Coverage

Continental U.S.

Orders for Alaska, Hawaii, and Puerto Rico will be shipped F.O.B. inland carrier point of exportation.

5. Point of Production

Zeeland, Ottawa County, Michigan
Spring Lake, Ottawa County, Michigan

6. Pricing

Prices shown are list. Discounts include Industrial Funding Fee.

SIN 711-1

Product: Selected Action Office 1, Action Office 2, C-Style Overhead Storage, Ethospace System, Quadrant Pedestals, Supplemental Products, Tu Pedestals and Pedastools, and approved Herman Miller Options Products.

Standard Lead Time	Single Order Net Purchase	Discount From list
	\$100 - 250,000	73.8%
	\$250,001 - 500,000	76.8%

SIN 711-1

Product: Selected Renew™ Tables, Renew Link and approved Herman Miller Options Products

Standard Lead Time	Single Order Net Purchase	Discount From List
	\$100 - 500,000	72.8%

SIN 711-1

Product: Selected Motia™ Tables, and approved Herman Miller Options Products

Standard Lead Time	Single Order Net Purchase	Discount From List
	\$100 - 500,000	73.8%

SIN 711-1

Product: Tu Wood Pedestals and approved Herman Miller Options Products

Standard Lead Time	Single Order Net Purchase	Discount From List
	\$100 - 300,000	74.3%

SIN 711-1

Product: Selected Canvas Office Landscape and approved Herman Miller Options Products

Standard Lead Time	Single Order Net Purchase	Discount From List
	\$100 - 500,000	74.8%

SIN 711-1

Product: Selected Layout Studio® and approved Herman Miller Options Products

Standard Lead Time	Single Order Net Purchase	Discount From List
	\$100 - 500,000	60.7%

SIN 711-1

Product: Selected Meridian Pedestals, Meridian Pedastools, and approved Herman Miller Options Products

Standard Lead Time	Single Order Net Purchase	Discount From List
	\$100 - 500,000	64.2%

Contract Information

continued

SIN 711-1

Product: Selected Thrive Portfolio and approved Herman Miller Options Products

Standard Lead Time	Single Order Net Purchase	Discount From List
	\$100 - 250,000	62%
	\$250,001 - 500,000	66.4%

SIN 711-2

Product: Passage Desking System and approved Herman Miller Options Products

Standard Lead Time	Single Order Net Purchase	Discount From List
	\$100 - 500,000	56.7%

SIN 711-2

Product: 5000 Series Furniture and approved Herman Miller Options Products

Standard Lead Time	Single Order Net Purchase	Discount From List
	\$100 - 500,000	58.7%

SIN 711-3

Product: Meridian Laterals, Verticals, Towers, and Storage products and approved Herman Miller Options Products

Standard Lead Time	Single Order Net Purchase	Discount From List Laterals	Verticals	Towers & Storage
	\$100 - 300,000	67.3%	66.3%	62.7%

SIN 711-3

Product: Tu Lateral Files, Tu Storage, Tu Towers, Tu Wood Cases, Tu Wood Cubbies, Tu Wood Credenzas, Tu Wood Towers, and approved Herman Miller Options Products

Standard Lead Time	Single Order Net Purchase	Discount From List
	\$100 - 300,000	74.3%

SIN 711-11

Product: Selected Tables and Accessories and approved Herman Miller Options Products

Standard Lead Time	Single Order Net Purchase	Discount From List
Avive® Tables	\$100 - 250,000	72.8%
	\$250,001 - 500,000	74.8%
Herman Miller Eames® Tables	\$100 - 250,000	73.6%
	\$250,001 - 300,000	77.6%
Everywhere™ Tables	\$100 - 300,000	72.8%

SIN 711-16

Product: Swoop upholstered seating products and approved Herman Miller Options Products

Standard Lead Time	Single Order Net Purchase	Discount From List
Swoop™	\$100 - 200,000	60.7%

SIN 711-18

Product: Selected Seating and approved Herman Miller Options Products

Standard Lead Time	Single Order Net Purchase	Discount From List
Aeron® (Classic and New)	\$100 - 200,000	64.5%
Aside®	\$100 - 200,000	64.2%
Caper®	\$100 - 200,000	61.5%
Celle®	\$100 - 200,000	59.7%
Embody®	\$100 - 200,000	59.7%
Equa 2®	\$100 - 200,000	65.8%
Ergon 3®	\$100 - 200,000	68.8%
Keyn	\$100 - 200,000	57.7%
Mirra® 2	\$100 - 200,000	61.7%
Setu®	\$100 - 200,000	59.7%
Sayl®	\$100 - 200,000	62.2%
Verus™	\$100 - 200,000	63.7%

SIN 711-99

Product: Selected Exclave™, Locale®, Public Office Landscape®, Resolve® System, and approved Herman Miller Options Products

Standard Lead Time	Single Order Net Purchase	Discount From List
Exclave	\$100 - 50,000	61.7%
Locale	\$100 - 50,000	63.7%
Public Office Landscape	\$100 - 50,000	61.7%
Resolve System	\$100 - 50,000	69.8%
Intent Solution	\$100 - 50,000	58.7%

7. Quantity Discounts

Reference item #6.

8. Payment Term

Net 30 days

9. Government Commercial Credit Card

- Government commercial credit cards are accepted below the micropurchase threshold.
- Government commercial credit cards are accepted above the micropurchase threshold.

10. Foreign Items

None

11. Time of Delivery

- 90 day ARO
- Expedited delivery: Items listed in the 10-Day section of the catalogs are available for expedited delivery.
- Overnight/2-day delivery: Select items may be available for overnight or 2-day delivery. Contact Herman Miller or a participating dealer for availability and rates.
- Urgent requirements: Agencies may contact contractor or participating dealer to request faster delivery.

Contract Information

continued

12. F.O.B.

F.O.B. destination except Alaska, Hawaii, and Puerto Rico, which will be shipped F.O.B. inland carrier point of exportation.

13. Ordering Address

- a. Herman Miller, Inc.,
Government Customer Care 0161
855 East Main Avenue
Zeeland MI 49464.
- b. For supplies and services, the ordering procedures information on Blanket Purchase Agreements (BPA's) and a sample BPA can be found at the GSA/FSS Schedule homepage (www.fss.gsa.gov/schedules).

14. Payment Address.

Herman Miller, Inc.
22764 Network Place
Chicago, IL 60673-1227

15. Warranty

Herman Miller, Inc., commercial warranty applies.

16. Export Packing Charge

Prices supplied on request.

17. Terms and Conditions of Government Purchase Card Acceptance

(any thresholds above the micropurchase level)
None.

18. Rental Maintenance and Repair Terms

Not applicable

19. Terms and Conditions of Installation

Installation Services will be provided by Herman Miller, Inc., or its participating dealer based on a fee not to exceed \$55 per hour (\$82.50 per hour for after-hours Installation), which applies to services totaling \$150,000 (per SIN) and below only. Services above \$150,000 shall be negotiated on a case-by-case basis.

Additional Notes for Installation & Reconfiguration and Relocation Services:

FOB Destination (Drop Ship): Price includes product delivery to the site, brought to the tailgate of the truck. The purchaser is responsible for unloading.

Prices effective up to the maximum order by SIN only. Above the MO, pricing shall be negotiated on a case-by-case basis between the client and local dealer.

Standard Services are Subject to the Following Conditions:

Installation will be performed during normal weekday working hours.

Adequate facilities for delivery, unloading, moving and staging/storing the product during the installation process shall be provided.

Service work will not be hindered by other trades.

Electric, heat, and adequate elevator service will be furnished without charge.

The immediate installation area shall be complete and free of debris including the carpet/flooring before installation commences.

Any work requiring a licensed electrician is the responsibility of the buyer.

Additional Charges May Apply For:

Major Metro Markets and any non-ground floor installation.

Major Metro Markets include large population centers and urban environments.

Installation in a clinical/medical environment.

Special restrictions or limits established by local laws, ordinances or the directions of the buyer, including but not limited to restrictions on transportations of materials, street access to the job site and/or dock facilities.

Installations outside of a 50 mile radius of the servicing dealer.

Local Prevailing Wage and/or Union Labor Rates.

Any additional charges shall be quoted by the dealer and approved by the buyer prior to performance of the work.

20. Terms and Conditions of Repair Parts

Not applicable

21. Service and Distribution Points

For service and distribution points nearest you, call (800) 851 1196.

22. Participating Dealers

Access Herman Miller web site for current list of participating dealers: www.HermanMiller.com/government.

23. Preventive Maintenance

Not applicable

24a. Special Attributes.

2018

For the 11th consecutive year, Herman Miller received a perfect score on the Corporate Equality Index and we were designated as Best Place to Work for LGBT equality. This report evaluates U.S. companies in terms of diversity, particularly their LGBT-related policies and practices.

Contract Information

continued

2017

Herman Miller was named the 2017 “Corporation of the Year” in the consumer products sector by the Michigan Minority Supplier Development Council (MMSDC).

Herman Miller has received a 2017 SEAL (Sustainability, Environmental Achievement and Leadership) Business Sustainability Award.

Herman Miller has earned the 4 Star Diversity Visionary Award. This award celebrates the diversity, equality, and inclusion work of Herman Miller. The award is presented at the annual Diversity Equity Inclusion Summit, held by the Grand Rapids Area Chamber of Commerce.

Herman Miller named one of the Best and Brightest in Wellness for the fifth year in a row.

Working Mother magazine has recognized Herman Miller as one of the 2017 Working Mother 100 Best Companies.

Herman Miller earned our tenth consecutive perfect score in Human Rights Campaign (HRC) Foundation’s 2017 Corporate Equality Index.

As one of the top-scoring companies in our industry for the thirteenth consecutive year, Herman Miller has qualified for inclusion in RobecoSAM’s 2017 Sustainability Yearbook and received the Bronze Class distinction for our excellent economic, environmental, and social sustainability performance.

Herman Miller has once again earned the WorldatWork Seal of Distinction, a unique standard of excellence in work-life effectiveness that shows we provide a distinct, mutually beneficial workplace experience.

2016

Herman Miller was recognized as the Business of the Year at the Annual Meeting of the West Michigan Environmental Action Council (WMEAC). This award goes to the business with the greatest depth and breadth of support, unwavering dedication to environmental action in West Michigan, and a strong corporate commitment to environmental advocacy.

The 101 Best and Brightest Sustainable Companies once again (fifth consecutive year) recognized Herman Miller as an organization in Michigan (and for the first time, in the nation) that exhibits leadership and innovation in its approach to sustainability.

Herman Miller has been recognized by the Michigan Minority Supplier Development Council (MMSDC), as a “Corporation of the Year”, and we also received a “2016 Excellence in Supplier Diversity Award” from the Great Lakes Women’s Business Council. Additionally, we are the only West Michigan company this year to receive an “Ambassadors Championing Excellence” Award from the MMSDC.

Plex Lounge Furniture from Herman Miller receives #MetropolisLikes award at NeoCon 2016.

Plex Lounge Furniture from Herman Miller receives Interior Design HiP Award for Workplace Seating/Lounge at NeoCon 2016.

Spot Stools from Herman Miller Collection receive Interior Design HiP Award for Hospitality Seating at NeoCon 2016.

Herman Miller has been named a 2020 Women on Boards Winning Company. Companies selected for this recognition are considered champions of board diversity as 20 percent or more of their board seats are occupied by women.

Herman Miller selected for inclusion in the 2016 RobecoSAM Sustainability Yearbook for twelfth consecutive year.

Herman Miller again earns the WorldatWork Work-Life 2016 Seal of Distinction. This award identifies organizations that focus on programs that promote work-life balance and overall well-being.

2015

Herman Miller earns ninth consecutive perfect score in Human Rights Campaign (HRC) Foundation’s 2016 Corporate Equality Index and we were designated as Best Place to Work for LGBT equality.

This is the fourth consecutive year that Herman Miller was named one of Michigan’s Best and Brightest Sustainable Companies.

Herman Miller has received the Best and Brightest in Wellness Award for the third year in a row. This program is an innovative initiative that recognizes and celebrates quality and excellence in health awareness.

Herman Miller received the Forest Stewardship Council (FSC) Leadership Award for longstanding commitment to manufacturing with wood sourced from responsibly managed forests, which reduces environmental impacts by protecting against deforestation and forest degradation.

Herman Miller accepted its second Excellence in Reusable Packaging Award from the Reusable Packaging Association.

Herman Miller has once again been recognized for its commitment to best-in-class economic, environmental, and societal sustainability, earning a spot on the prestigious Dow Jones Sustainability Index (DJSI) for the twelfth consecutive year. We are the only contract furniture company recognized globally for its corporate sustainability leadership.

Herman Miller selected for inclusion in the 2015 RobecoSAM Sustainability Yearbook; awarded Bronze Class distinction for excellent sustainability performance for the second consecutive year.

Contract Information

continued

Herman Miller received a Michigan Business Pollution Prevention (MBP₃) Certificate – a recognition given by the Michigan Department of Environmental Quality (MDEQ) to organizations committed to environmental stewardship, conservation, and sustainable operations. This basic partnership with the MDEQ, which we've maintained since 1998, makes us eligible for our Clean Corporate Citizen (CCC) status that began in 2004 and our Environmental Leader status, which we received for the first time this past year.

MedAssets named Herman Miller Healthcare as Platinum Suppliers. MedAssets, a large group purchasing organization, helps providers enhance operational and financial performance so they can sustainably serve the needs of their community.

Herman Miller honored with five of 20 spots for the Michigan Environmental Leaders Award by the Michigan Department of Environmental Quality for our outstanding, voluntary environmental stewardship.

Renew Sit-to-Stand tables recognized on Record Products 2014 list by Architectural Record.

Herman Miller was again awarded a perfect score in the 2015 Corporate Equality Index. This is the eighth consecutive year we received a perfect score.

2014

Herman Miller has received the Best and Brightest in Wellness Award for the second year in a row. This program is an innovative initiative that recognizes and celebrates quality and excellence in health awareness.

Herman Miller's Locale wins International Design Excellence Awards (IDEA) Gold in the Office & Productivity category.

Herman Miller achieves eleventh consecutive listing on Dow Jones Sustainability World Index, an international stock portfolio that evaluates the annual performance of the world's largest 2500 companies using economic, environmental, and social criteria, known as the "triple bottom line" of sustainability.

2013

Herman Miller achieves tenth consecutive listing on Dow Jones Sustainability World Index.

Herman Miller has received the Best and Brightest in Wellness Award. This program is an innovative initiative that recognizes and celebrates quality and excellence in health awareness.

Herman Miller Earns Perfect Score on the Corporate Equality Index. We are one of only 303 major U.S. businesses to receive a perfect score in 2013, an achievement we have now obtained seven years in a row.

Herman Miller is listed in Forbes Magazine inaugural "Platinum List" of America's 400 best managed, large companies.

For the second consecutive year, Herman Miller is honored as one of West Michigan's "101 Best and Brightest Sustainable Companies".

2012

Herman Miller accepted its first Excellence in Reusable Packaging Award from the Reusable Packaging Association.

Herman Miller is named "Corporation of the Year" in the commercial products sector by the Michigan Minority Supplier Development Council.

In July 2012 Herman Miller was inducted into the Made in the USA Hall of Fame. Herman Miller is one of only 20 companies across the nation to receive this distinction.

Herman Miller achieves ninth consecutive listing on Dow Jones Sustainability World Index.

Herman Miller is honored as one of West Michigan's 101 Best and Brightest Sustainable Companies.

The Sustainable Asset Management (SAM) group selected Herman Miller for inclusion in "The Sustainability Yearbook 2012" and has awarded Herman Miller both the "SAM Sector Leader" and "SAM Sector Mover" distinctions.

Herman Miller was named one of 16 Section Leaders on Climate Counts 2011-2012 Scorecard Report, making us the industry leader for Home and office Furnishings.

SGS International Certification Services, Inc., recognizes Herman Miller's manufacturing sites, Midwest Distribution Center, and Design Yard for initial certification to the OHSAS 18001 standard as well as re-certification to ISO 14001.

2011

Trust Across America, a company dedicated to unraveling the complexities of trustworthy business behavior, listed Herman Miller as one of their "Top Ten Most Trustworthy Companies in America 2011."

The U.S. Environmental Protection Agency (EPA) selected Herman Miller, as a WasteWise Gold Achievement—Climate Change winner.

Herman Miller achieves eighth consecutive listing on Dow Jones Sustainability World Index, an international stock portfolio that evaluates the annual performance of the world's largest 2500 companies using economic, environmental, and social criteria, known as the "triple bottom line" of sustainability.

The Michigan Minority Supplier Development Council (MMSDC) named Herman Miller as its "Corporation of the Year" in the commercial products sector. This was the fifth time Herman Miller has received this award since 2005.

Contract Information

continued

Herman Miller accepted its third Neighborhood Environmental Partners (NEP) award from the Michigan Department of Natural Resources and Environment.

Herman Miller receives the Reader's Choice award from TreeHugger's Best of Green: Design and Architecture category for the SAYL chair.

Herman Miller earns Citibank's Global Environmental Vendor of the Year award.

The SAYL chair from Herman Miller was dubbed the "Product Design of the Year" from the 2010 International Design Awards (IDA) jury.

Herman Miller Healthcare's Compass system was awarded a 2011 Medical Design Excellence Award (MDEA) for its research-based design and ability to be used in a variety of healing spaces, while simultaneously improving the overall delivery of healthcare.

The Sustainable Asset Management (SAM) Group selected Herman Miller for inclusion in the "Sustainability Yearbook 2011" and awarded us both the "SAM Sector Leader" and "SAM Sector Mover" distinctions.

Herman Miller has received the top rating for a fourth consecutive year in the Human Rights Campaign (HRC) Foundation's eighth annual Corporate Equality Index. The "Best Places to Work for LGBT Equality" distinction is awarded to businesses that scored 100% on the HRC Foundation's 2011 Corporate Equality Index.

Herman Miller again tops contract furniture industry in FORTUNE's "Most Admired" Companies survey. For the 23rd time in 25 years.

2010

The NASDAQ OMX CRD Global Sustainability Index (QCRD) has included Herman Miller among their top 100 companies in the world.

Herman Miller achieves seventh consecutive listing on Dow Jones Sustainability World Index, an international stock portfolio that evaluates the annual performance of the world's largest 2500 companies using economic, environmental, and social criteria, known as the "triple bottom line" of sustainability. Herman Miller is one of approximately 300 companies worldwide and the only contract office furniture manufacturer, selected for this index.

Herman Miller has been recognized by Fast Company magazine as one of its 2010 Most Innovative Companies and among the more select Innovation All-Stars.

The U.S. Environmental Protection Agency's Office of Resource Conservation and Recovery has selected Herman Miller to receive the 2010 WasteWise Gold Achievement Award for Green Purchasing.

The Michigan Department of Natural Resources and Environment (MDNRE) has recognized Herman Miller's West Michigan manufacturing sites and Midwest Distribution Center as continuing Clean Corporate Citizens.

Herman Miller makes the U.S. Environmental Protection Agency's (EPA) list of the top fifty users of renewable electricity, of more than 1,200 organizations participating in the Green Power Partnership. This is the second consecutive time Herman Miller was recognized. Herman Miller was the only furniture manufacturer on the list.

Herman Miller accepted its second Neighborhood Environmental Partners (NEP) award from the Michigan Department of Natural Resources and Environment.

For the 22nd time in 24 years, Herman Miller was awarded the No. 1 industry ranking in a survey among the executives and board members of peer companies and independent industry analysts, as published in FORTUNE magazine's annual "Most Admired" companies feature.

The Michigan Department of Environmental Quality (MDEQ) recognizes Herman Miller's GreenHouse as one of Michigan's top environmental performers with a Clean Corporate Citizen (C3) longevity award. This recognizes that the GreenHouse has maintained its C3 designation for the past five years.

For the third year in a row, Herman Miller makes FORTUNE magazine's "100 Best Companies to Work For" list. Herman Miller is one of only three Michigan-based companies to make the list.

24b. Section 508 Compliance

Not applicable

25. Data Universal Numbering System (DUNS): 00-601-2801

26. Registered in System for Award Management (www.SAM.gov) Database

27. Cancellation

Prior to production, no cancellation charge will apply. After production, only actual cost incurred that the contractor can demonstrate if items are sold after 3 months.

28. Restocking Charges

Agencies must notify the contractor for authorization prior to returning any items. The customer agency will be required to pay all packaging and return freight charges. A restocking fee of 50% for Systems Furniture and 35% for all other product lines will be charged for any returned items.

Herman Miller Miscellaneous Information:

Federal ID Number: 38-0837640

Commercial and Government Entity Code (CAGE): 40636

Data Universal Numbering System (DUNS) 00-601-2801

Commercial Entity Code (CEC): 00702290J

Introduction	page 2
Public Office Landscape®	3
Seating	5
Desking and Storage	12
Power	30
Tables	47
Space Delineation	58
Indices	63
By Name	63
By Number	65
Appendices	
20-Day or Less/Assigned Lead-Time Order Information	
Proprietary Textiles Application Chart-Workspaces	
Proprietary Textile Colors-Workspaces	
Proprietary Textiles Application Chart-Seating	
Proprietary Textile Colors-Seating	
For the latest materials information, refer to the Materials pages on HermanMiller.com.	

Introduction

A Note on the Organization of This Book

There are a few signals that will help you understand the organization of this book. Once you know them, you should be able to find your way around easily.

Like a newspaper, this book is formatted with columns of text and illustrations that run vertically.

Information wraps from one column to the next and continues for as many pages as it needs to.

Black bars are clues.

A black bar at the top of a page signals the start of information about a product.

This information is divided into two sections, each signaled by a black bar. Product Information includes a description, additional notes, and dimensional drawings. Specification Information, which always begins at the top of a column, includes a series of steps. Each step represents a decision you need to make in order to complete your product number. Steps must be followed sequentially. The number of pages needed to complete information on a product varies; some will be complete in one page; others may fill three or four pages. Just continue going through the steps until you run into the next product, signaled by the black bar at the top of the page.

Black tabs running along the outside edge of the page help you locate what section you are in or what section you want to go to. You can thumb forwards or backwards to find a section; tabs and text appear on both sides of the page.

The additional pages in the back of the book include the appendices and indices. They are signaled by a long black bar running along the outside edge of the page.

The index is presented two ways.

The first index is in alphabetical order by product name. It can be helpful if you are new to the products and numbering scheme or if you are looking for a type of product, such as work chair or round table.

The second index is by product number. It lists, in alphanumeric order, the base product number, typically a five-digit number.

This book is effective April 2, 2018, subject to change without notice. Products may be purchased from authorized Herman Miller dealers who will quote prices upon request. For more information about our products and services or to see a list of dealers, visit www.HermanMiller.com.

All prices are list prices in US Dollars. Additional services, such as planning services, design, storage, and installation, are not included and must be added to these prices when the additional services are requested.

Illustrations, specifications, and prices are based on the latest information at the time of publication. The right is reserved to make changes at any time without notice in prices, fabrics, finishes, materials, specifications, and models, and also to discontinue models and finishes.

Dimensions shown in the drawings are engineering drawing dimensions rounded up to the nearest $\frac{1}{8}$ ". Product is shipped set up or knocked down. Products that include "Shipped knocked down" in the description require some assembly. If this statement does not appear in the description, the product is shipped assembled.

Service problems are normally handled by a Herman Miller authorized dealer. Where this cannot be accomplished on a local level, service problems should be referred to the Customer Care Representative for your region, Herman Miller, Inc., Zeeland, Michigan 49464.

20-Day or Less/Assigned Lead-Time Shipments

All products and options in this price book not designated by an Assigned Program icon  will ship in **20 business days or less** after being acknowledged by Herman Miller.

Products and options designated by an  are on the assigned lead-time program and may ship in 20 days, less than 20 days, or more than 20 days from order acknowledgement.

Seating

Desking and Storage

Power

Tables

Space Delineation



Social Chair

BVS1N.

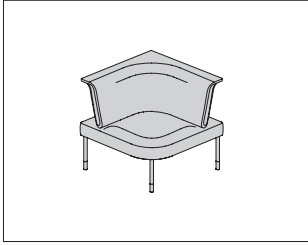

Product Information

Description

This chair has an upholstered foam seat on an expanded polypropylene base, with a Network-wrapped suspension back. The chair can be freestanding next to a desk or connected to other social chairs or café tables. It accepts the attachment of screens. It comes with legs for freestanding applications or without legs when attached to other chairs. Legs have glides that provide up to 2" of adjustment.

Notes

- Chair supports attachment of 2 screens.
- When specified without legs, order seating legs (BVS3.) separately.
- Network color and back loop frame color will match.
- Seat fabric is railroaded.
- Customers Own Material can only be specified for seat fabric. See Customers Own Material Order Information in appendices.
- Seat accepts Customer's Own Material (COM). Yardage is estimated for nondirectional 54"-wide fabrics. Order 2.16 yards of fabric per cushion. For information on multiple quantities or directional fabrics, contact COM Department. See Order Information in Appendices.

Dimensions

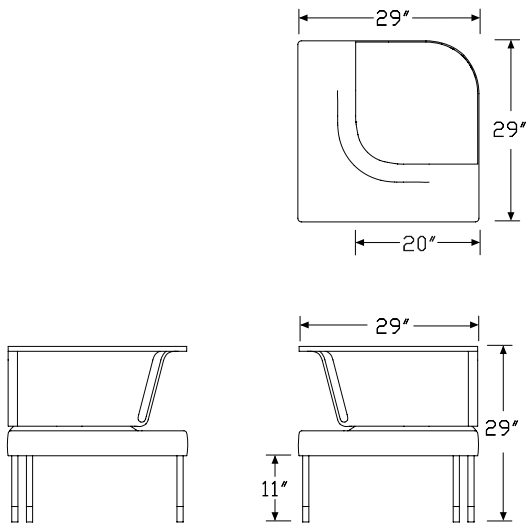

Specification Information

Step 1.

BVS1N.

Step 2. Seat Style

- L** left
- R** right

Step 3. Leg Option

- L** legs
- N** no legs

Step 4. Fire Retardancy

- For not fire retardant (*), skip this step.*
- not fire retardant

Prices for Steps 1-4.

		*
BVS1N.L	L	\$1857
	N	\$1857
	R L	\$1857
	N	\$1857

Step 5. Glide Option

- For legs (L)*
- C** nylon glide, carpet floors + \$0

Step 6. Leg Finish

- For legs (L)*
- G1** graphite + \$0
- 91** white + \$0
- MS** metallic silver + \$10

Step 7. Glide Finish

- For graphite (G1)*
- BK** black + \$0
- For white (91)*
- 8Q** folkstone grey + \$0
- For metallic silver (MS)*
- 63** fog + \$0

Social Chair *continued*

Step 8. Back Frame Finish		
91	white	+\$0
G1	graphite	+\$0
RO	red	+\$0
97	twilight	+\$0
63	fog	+\$0
79	green apple	+\$0
WBY	wild berry	+\$0

Step 9. Back Knit Color		
-------------------------	--	--

<i>For white (91)</i>		
1A901	warm white	+\$0

<i>For graphite (G1)</i>		
1A907	graphite	+\$0

<i>For red (RO)</i>		
1A903	red	+\$0

<i>For twilight (97)</i>		
1A906	twilight blue	+\$0

<i>For fog (63)</i>		
1A902	fog	+\$0

<i>For green apple (79)</i>		
1A905	green apple	+\$0

<i>For wild berry (WBY)</i>		
1A904	wild berry	+\$0

Step 10. Seat Fabric		
	Price Category 1	+\$0
	Price Category 2	+\$25
	Price Category 3	+\$46
	Price Category 4	+\$90
	Price Category 5	+\$134

Sectional Seating

BVS2N.

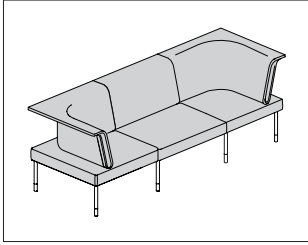

Product Information

Description

The sectional seat comes in straight, right-corner, and left-corner styles. It has an upholstered foam seat on an expanded polypropylene base, with a Network-wrapped suspension back. Sectional seats connect to other sectional seats and social chairs and accept the attachment of screens.

Notes

- Order seating legs (BVS3.) separately.
- Corner-style seats support 2 screens. Straight-style seats support 1 screen.
- Network color and back loop frame color will match.
- Seat fabric is railroaded.
- Customers Own Material can only be specified for seat fabric. See Customers Own Material Order Information in appendices.
- Seat accepts Customer's Own Material (COM). Yardage is estimated for nondirectional 54"-wide fabrics.
- Seat style—Yardage
- CR—2.16
- CL—2.16
- 29—2.21
- For information on multiple quantities or directional fabrics, contact COM Department. See Order Information in Appendices.

Dimensions

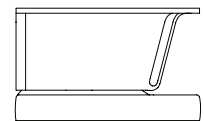
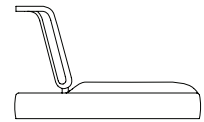
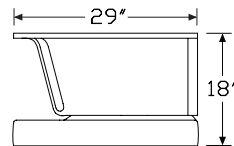
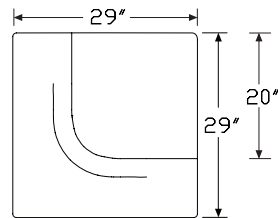
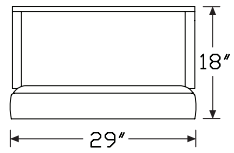
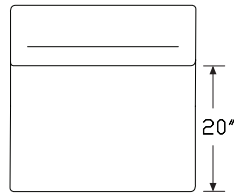

Sectional Seating *continued*

Specification Information	
Step 1.	
BVS2N.	
Step 2. Seat Style	
CR	corner right
CL	corner left
29	straight, 29"
Step 3. Fire Retardancy	
<i>For not fire retardant (*), skip this step.</i>	
not fire retardant	
Prices for Steps 1-3.	
*	
BVS2N.CR	\$1857
CL	\$1857
29	\$1857
Step 4. Back Frame Finish	
91	white +\$0
G1	graphite +\$0
RO	red +\$0
97	twilight +\$0
63	fog +\$0
79	green apple +\$0
WBY	wild berry +\$0
Step 5. Back Knit Color	
<i>For white (91)</i>	
1A901	warm white +\$0
<i>For graphite (G1)</i>	
1A907	graphite +\$0
<i>For red (RO)</i>	
1A903	red +\$0
<i>For twilight (97)</i>	
1A906	twilight blue +\$0
<i>For fog (63)</i>	
1A902	fog +\$0
<i>For green apple (79)</i>	
1A905	green apple +\$0

<i>For wild berry (WBY)</i>	
1A904	wild berry +\$0
Step 6. Seat Fabric	
Price Category 1	+\$0
Price Category 2	+\$25
Price Category 3	+\$46
Price Category 4	+\$90
Price Category 5	+\$134

Legs

BVS3.

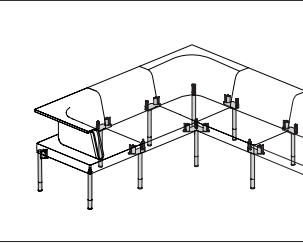

Product Information

Description

Seating legs provide 4 attachment options to accommodate the various configurations of social chairs and sectional seats. Legs have glides that provide up to 2" of adjustment.

Notes

When specifying trivalent chrome (47) finish option, glide color must be specified separately.

Dimensions

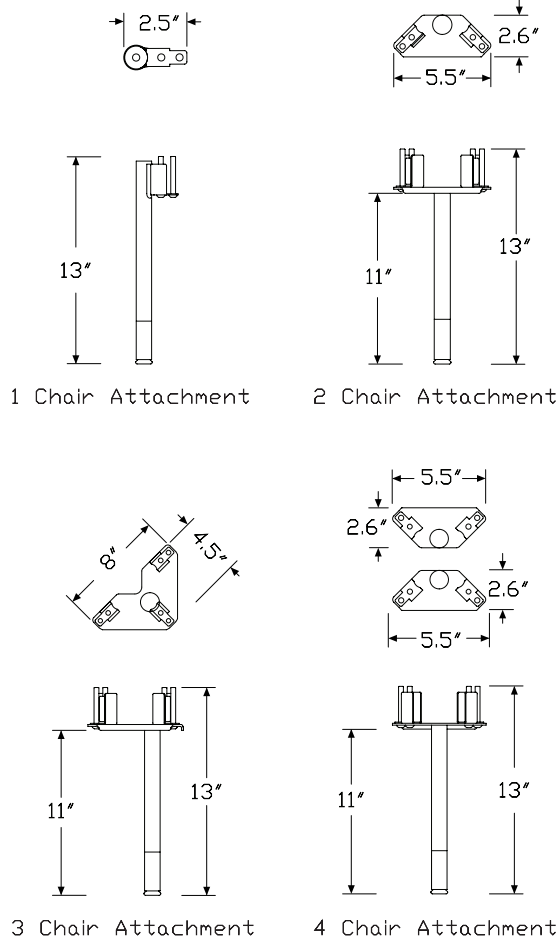

Specification Information

Step 1.

BVS3.

Step 2. Leg Option

- 1 attaches to one chair
- 2 attaches to two chairs
- 3 attaches to three chairs
- 4 attaches to four chairs

Prices for Steps 1-2.

BVS3. 1	\$54
2	\$79
3	\$111
4	\$159

Step 3. Glide Option

C	nylon glide, carpet floors	+\$0
----------	----------------------------	------

Step 4. Leg Finish

91	white	+\$0
G1	graphite	+\$0
MS	metallic silver	+\$5
47	trivalent chrome	+\$10

Step 5. Glide Finish

For graphite (G1)

BK	black	+\$0
-----------	-------	------

For white (g1)

8Q	folkstone grey	+\$0
-----------	----------------	------

For metallic silver (MS)

63	fog	+\$0
-----------	-----	------

For trivalent chrome (47)

BK	black <input type="checkbox"/>	+\$0
8Q	folkstone grey <input type="checkbox"/>	+\$0
63	light grey <input type="checkbox"/>	+\$0

Seat Back Ganging Kit

BVS4.

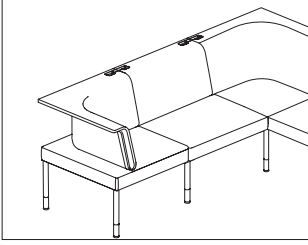

Public Office Landscape® Seating

Product Information

Description
This seat back ganging kit aligns 2 sectional seats that are side-by-side.

Dimensions

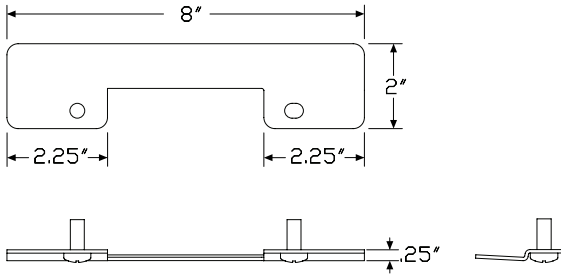

Specification Information

Step 1.	
BVS4.	\$30
Step 2. Leg Option	
2 ganging kit for 2 seats	+\$0

Seat Back Alignment Clip

BVS5.

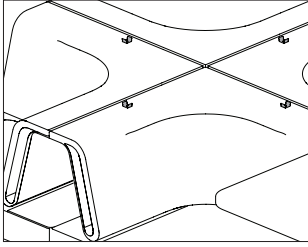

Product Information

Description

This seat back alignment clip aligns 2 chairs that are back-to-back.

Dimensions

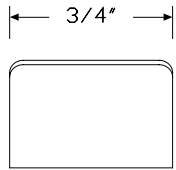
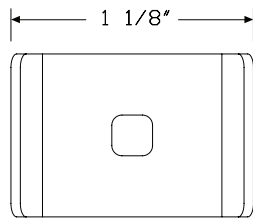

Specification Information

Step 1.

BVS5.1

\$15

Desk

BVD1.

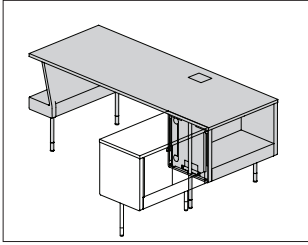

Public Office Landscape® Desking and Storage

Product Information

Description

Desks have 4 legs and are intended to connect with other desks and connecting bins. Desks have a laminate, veneer, or Formcoat® squared-edge work surface with a painted steel understructure bin on 1 side and a steel shelf with a bag hook on the other side. Desks will support a screen on the shelf side, and on the bin side when the bin does not have doors, and will accommodate desktop dividers. Understructure bins come in left or right orientation, with or without doors. Bin divider included. Legs have glides that provide up to 2" of adjustment.

Power bridge desk allows power to be run from desk-bin side to L-shelf side of the desk to accommodate powering other desks or café surfaces from a single power entry point. The desk bin and L-shelf have the same appearance as on the power access desk, but have different internal structures and components to support power across the desk.

Notes

To connect desk to a connecting bin (BVD2.) or another desk (BVD1.), order desk and bin ganging plate (BVD5.C) separately.

All connecting bins (BVD2.) require the use of both bin-to-bin and desktop-to-desktop ganging plates. Order desk and bin ganging plate (BVD5.C) separately.

The exposed end of the understructure bin requires a desk and bin finishing kit (BVD4.), ordered separately.

Desk accepts modular power (BVEo1., BVEo2.) through the bottom of the understructure bin.

To bring power to the surface of a desk, order Logic Mini, Grommet Mount (Y1414.) separately.

Bin divider is field installed and can be specified in a complementary color.

Grommet color is either graphite or white, matched to the work surface color.

Bag hook color is matched to shelf color.

When specifying trivalent chrome (47) leg finish, glide color is predetermined to coordinate with specified desk finish:

- Graphite (G1) desk will have black (BK) glides
- Metallic silver (MS) desk will have fog (63) glides
- White (G1) desk will have folkstone grey (8Q) glides

Power bridge desk includes cable management channel and L-shelf cover for beam connection.

Power access desk can be ordered with or without doors. The power bridge desk can only be ordered without doors, to accommodate the power bridge components.

See Planning Guide for more information about settings.

Dimensions

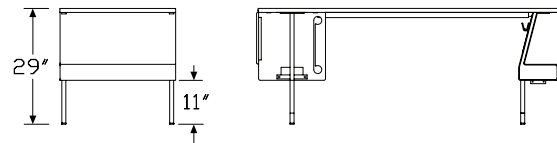
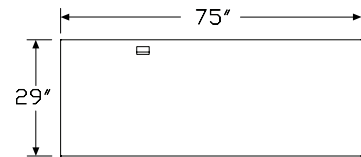

Specification Information

Step 1.

BVD1.

Step 2. Depth

29 29" deep

Step 3. Width

75 75" wide

Step 4. Power Access

P power access

B power bridge desk **A**

Step 5. Bin Orientation

R bin right

L bin left

Step 6. Bin Doors

For power access (P)

D doors

N no doors

For power bridge desk (B)

N no doors

Step 7. Top Material

L laminate top/thermoplastic edge

T formcoat®

W veneer

Prices for Steps 1-7.

	PRDL	PRDT	PRDW	PRNL	PRNT	PRNW
BVD1. 29 75	\$2057	2160	2469	1914	2010	2297

	PLDL	PLDT	PLDW	PLNL	PLNT	PLNW
BVD1. 29 75	\$2057	2160	2469	1914	2010	2297

	BRNL	BRNT	BRNW	BLNL	BLNT	BLNW
BVD1. 29 75	\$2075	2171	2458	2075	2171	2458

Step 8. Top Finish

For laminate top/thermoplastic edge (L)

76	light brown walnut	+\$0
8Q	folkstone grey	+\$0
91	white	+\$0
98	studio white	+\$0
CL	cool grey neutral	+\$0
HF	inner tone light	+\$0
HM	natural maple	+\$0
HP	light anigre	+\$0
HT	inner tone	+\$0
HX	aged cherry	+\$0
HY	walnut on cherry	+\$0
LA	light ash	+\$0
LBA	clear on ash	+\$0
LBU	medium matte walnut	+\$0
LBB	oak on ash	+\$0
LBC	walnut on ash	+\$0
LBD	dark brown walnut	+\$0
LBE	medium red walnut	+\$0
LBF	neutral twill	+\$0
LBG	sarum twill	+\$0
LBH	earthen twill	+\$0
LBJ	graphite twill	+\$0
LBK	pewter mesh	+\$0
LBL	steel mesh	+\$0
LBM	crisp linen	+\$0
LBN	classic linen	+\$0
LBP	casual linen	+\$0
LBQ	white twill	+\$0
LM	mahogany	+\$0
LT	light tone	+\$0
LU	soft white	+\$0
MT	medium tone	+\$0
WL	sandstone	+\$0
WN	warm grey neutral	+\$0

For formcoat® (T)

8Q	folkstone grey	+\$0
91	white	+\$0
WL	sandstone	+\$0

<i>For veneer (W)</i>		
ET	clear on ash	+\$0
EU	oak on ash	+\$0
EV	walnut on ash	+\$0
2U	light brown walnut	+\$0
40	dark brown walnut	+\$0

Step 9. Edge Finish		
<i>For laminate top/thermoplastic edge (L)</i>		
76	light brown walnut	+\$0
8Q	folkstone grey	+\$0
8Z	neutral grey	+\$0
91	white	+\$0
98	studio white	+\$0
BU	black umber	+\$0
CL	cool grey neutral	+\$0
HF	inner tone light	+\$0
HM	natural maple	+\$0
HP	light anigre	+\$0
HT	inner tone	+\$0
HX	aged cherry	+\$0
HY	walnut on cherry	+\$0
JB	millwork cherry	+\$0
LA	light ash	+\$0
LBA	clear on ash	+\$0
LBU	medium matte walnut	+\$0
LBB	oak on ash	+\$0
LBC	walnut on ash	+\$0
LBD	dark brown walnut	+\$0
LBE	medium red walnut	+\$0
LBF	neutral twill	+\$0
LBG	sarum twill	+\$0
LBH	earthen twill	+\$0
LBJ	graphite twill	+\$0
LBK	pewter mesh	+\$0
LBL	steel mesh	+\$0
LBM	crisp linen	+\$0
LBN	classic linen	+\$0
LBP	casual linen	+\$0
LBQ	white twill	+\$0
LU	soft white	+\$0
MT	medium tone	+\$0
WL	sandstone	+\$0
WN	warm grey neutral	+\$0

Step 10. Leg Finish		
91	white	+\$0
G1	graphite	+\$0
MS	metallic silver	+\$10
47	trivalent chrome	+\$150

Step 11. Bin/Bin Doors/Shelf Finish		
<i>For metallic silver (MS)</i>		
MS	metallic silver	+\$5

<i>For graphite (G1)</i>		
G1	graphite	+\$0

<i>For white (91)</i>		
91	white	+\$0

<i>For trivalent chrome (47)</i>		
91	white	+\$0
G1	graphite	+\$0
MS	metallic silver	+\$5

Step 12. Bin Divider Color		
MS	metallic silver	+\$0
G1	graphite	+\$0
91	white	+\$0
RO	red	+\$30
79	green apple	+\$30
TRQ	turquoise	+\$30
MY3	yellow oxide	+\$30
SG	slate grey	+\$0

Step 13. Lock		
<i>For doors (D)</i>		
KA	keyed alike, black	+\$0
KC	keyed differently, chrome	+\$0
KD	keyed differently, black	+\$0
KQ	keyed alike, chrome	+\$0
NL	no lock	+\$0

Step 14. Grommet Selection		
91	white	+\$0
G1	graphite	+\$0

Connecting Bin

BVD2.

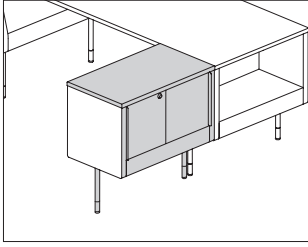

Product Information

Description

Connecting bins have 2 legs and are intended to connect with desks and other connecting bins. Connecting bins have a laminate, veneer, or Formcoat® top surface with a painted steel understructure bin. They come with or without doors, and allow power pass-through. Connecting bin will support a screen when the bin does not have doors. Bin divider included. Legs have glides that provide up to 2" of adjustment.

Notes

Connecting bins are not freestanding and will not support screens.

All connecting bins require the use of both bin-to-bin and desktop-to-desktop ganging plates. Order desk and bin ganging plate (BVD5.C) separately.

For stability when connecting to a desk (BVD1.) or another connecting bin (BVD2.), use both desktop-to-desktop and bin-to-bin ganging plates (BVD5.C), ordered separately.

The exposed end of the connecting bin requires a desk and bin finishing kit (BVD4.), ordered separately.

Bin divider is field installed and can be specified in a complementary color.

When specifying trivalent chrome (47) leg finish, glide color is predetermined to coordinate with specified bin finish:

- Graphite (G1) bin will have black (BK) glides
- Metallic silver (MS) bin will have fog (63) glides
- White (91) bin will have folkstone grey (8Q) glides

See planning guide for more information about settings.

Dimensions

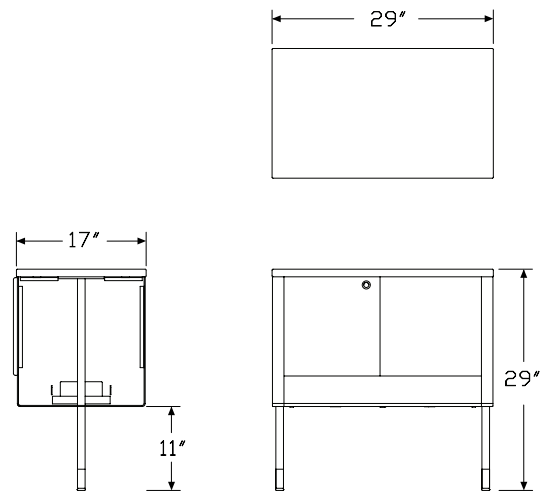

Specification Information

Step 1.

BVD2.

Step 2. Width

29 29" wide

Step 3. Bin Doors

D doors

N no doors

Step 4. Top Material

L laminate top/thermoplastic edge

T formcoat®

W veneer

Prices for Steps 1-4.

		L	T	W
BVD2.	29 D	\$1000	1050	1200
	N	\$857	900	1029

Step 5. Top Finish

For laminate top/thermoplastic edge (L)

76	light brown walnut	+\$0
8Q	folkstone grey	+\$0
91	white	+\$0
98	studio white	+\$0
CL	cool grey neutral	+\$0
HF	inner tone light	+\$0
HM	natural maple	+\$0
HP	light anigre	+\$0
HT	inner tone	+\$0
HX	aged cherry	+\$0
HY	walnut on cherry	+\$0
LA	light ash	+\$0
LBA	clear on ash	+\$0
LBU	medium matte walnut	+\$0
LBB	oak on ash	+\$0
LBC	walnut on ash	+\$0
LBD	dark brown walnut	+\$0
LBE	medium red walnut	+\$0
LBF	neutral twill	+\$0
LBG	sarum twill	+\$0
LBH	earthen twill	+\$0
LBJ	graphite twill	+\$0
LBK	pewter mesh	+\$0
LBL	steel mesh	+\$0
LBM	crisp linen	+\$0
LBN	classic linen	+\$0
LBP	casual linen	+\$0
LBQ	white twill	+\$0
LM	mahogany	+\$0
LT	light tone	+\$0
LU	soft white	+\$0
MT	medium tone	+\$0
WL	sandstone	+\$0
WN	warm grey neutral	+\$0

For formcoat® (T)

8Q	folkstone grey	+\$0
91	white	+\$0
WL	sandstone	+\$0

For veneer (W)

ET	clear on ash	+\$0
EU	oak on ash	+\$0
EV	walnut on ash	+\$0
2U	light brown walnut	+\$0
40	dark brown walnut	+\$0

Step 6. Edge Finish

For laminate top/thermoplastic edge (L)

76	light brown walnut	+\$0
8Q	folkstone grey	+\$0
8Z	neutral grey	+\$0
91	white	+\$0
98	studio white	+\$0
BU	black umber	+\$0
CL	cool grey neutral	+\$0
HF	inner tone light	+\$0
HM	natural maple	+\$0
HP	light anigre	+\$0
HT	inner tone	+\$0
HX	aged cherry	+\$0
HY	walnut on cherry	+\$0
JB	millwork cherry	+\$0
LA	light ash	+\$0
LBA	clear on ash	+\$0
LBU	medium matte walnut	+\$0
LBB	oak on ash	+\$0
LBC	walnut on ash	+\$0
LBD	dark brown walnut	+\$0
LBE	medium red walnut	+\$0
LBF	neutral twill	+\$0
LBG	sarum twill	+\$0
LBH	earthen twill	+\$0
LBJ	graphite twill	+\$0
LBK	pewter mesh	+\$0
LBL	steel mesh	+\$0
LBM	crisp linen	+\$0
LBN	classic linen	+\$0
LBP	casual linen	+\$0
LBQ	white twill	+\$0
LU	soft white	+\$0
MT	medium tone	+\$0
WL	sandstone	+\$0
WN	warm grey neutral	+\$0

Step 7. Leg Finish

91	white	+\$0
G1	graphite	+\$0
MS	metallic silver	+\$10
47	trivalent chrome	+\$75

Step 8. Bin/Bin Doors Finish

For metallic silver (MS)

MS	metallic silver	+\$5
-----------	-----------------	------

For graphite (G1)

G1	graphite	+\$0
-----------	----------	------

For white (91)

91	white	+\$0
-----------	-------	------

For trivalent chrome (47)

91	white	+\$0
G1	graphite	+\$0
MS	metallic silver	+\$5

Step 9. Bin Divider Color

MS	metallic silver	+\$0
G1	graphite	+\$0
91	white	+\$0
RO	red	+\$30
79	green apple	+\$30
TRQ	turquoise	+\$30
MY3	yellow oxide	+\$30
SG	slate grey	+\$0

Step 10. Lock

For doors (D)

KA	keyed alike, black	+\$0
KC	keyed differently, chrome	+\$0
KD	keyed differently, black	+\$0
KQ	keyed alike, chrome	+\$0
NL	no lock	+\$0

Upper Bin

BVD3.

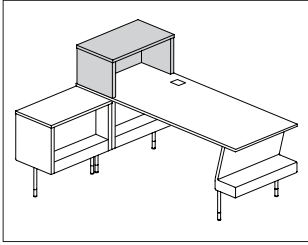

Public Office Landscape® Desking and Storage

Product Information

Description
 The upper bin sits on top of a desk, connecting bin, or freestanding bin. Upper bins have a laminate, veneer, or Formcoat® top surface with a painted steel frame.

Notes
 Upper bin does not require a desk and bin finishing kit. Bin divider is field installed and can be specified in a complementary color.

Dimensions

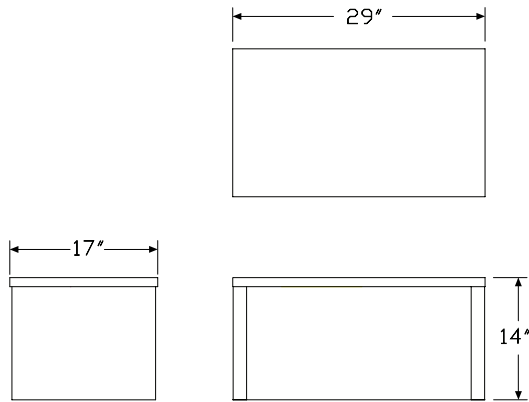

Specification Information

Step 1.

BVD3.

Step 2. Width

29 29" wide

Step 3. Top Material

L laminate top/thermoplastic edge

T formcoat®

W veneer

Prices for Steps 1-3.

	L	T	W
BVD3. 29	\$661	694	794

Step 4. Top Finish

For laminate top/thermoplastic edge (L)

76	light brown walnut	+\$0
8Q	folkstone grey	+\$0
91	white	+\$0
98	studio white	+\$0
CL	cool grey neutral	+\$0
HF	inner tone light	+\$0
HM	natural maple	+\$0
HP	light anigre	+\$0
HT	inner tone	+\$0
HX	aged cherry	+\$0
HY	walnut on cherry	+\$0
LA	light ash	+\$0
LBA	clear on ash	+\$0
LBU	medium matte walnut	+\$0
LBB	oak on ash	+\$0
LBC	walnut on ash	+\$0
LBD	dark brown walnut	+\$0
LBE	medium red walnut	+\$0
LBF	neutral twill	+\$0
LBG	sarum twill	+\$0
LBH	earthen twill	+\$0
LBJ	graphite twill	+\$0
LBK	pewter mesh	+\$0
LBL	steel mesh	+\$0
LBM	crisp linen	+\$0
LBN	classic linen	+\$0
LBP	casual linen	+\$0
LBQ	white twill	+\$0
LM	mahogany	+\$0
LT	light tone	+\$0
LU	soft white	+\$0
MT	medium tone	+\$0
WL	sandstone	+\$0
WN	warm grey neutral	+\$0

For formcoat® (T)

91	white	+\$0
8Q	folkstone grey	+\$0
WL	sandstone	+\$0

For veneer (W)

ET	clear on ash	+\$0
EU	oak on ash	+\$0
EV	walnut on ash	+\$0
2U	light brown walnut	+\$0
40	dark brown walnut	+\$0

Step 5. Edge Finish

For laminate top/thermoplastic edge (L)

76	light brown walnut	+\$0
8Q	folkstone grey	+\$0
8Z	neutral grey	+\$0
91	white	+\$0
98	studio white	+\$0
BU	black umber	+\$0
CL	cool grey neutral	+\$0
HF	inner tone light	+\$0
HM	natural maple	+\$0
HP	light anigre	+\$0
HT	inner tone	+\$0
HX	aged cherry	+\$0
HY	walnut on cherry	+\$0
JB	millwork cherry	+\$0
LA	light ash	+\$0
LBA	clear on ash	+\$0
LBU	medium matte walnut	+\$0
LBB	oak on ash	+\$0
LBC	walnut on ash	+\$0
LBD	dark brown walnut	+\$0
LBE	medium red walnut	+\$0
LBF	neutral twill	+\$0
LBG	sarum twill	+\$0
LBH	earthen twill	+\$0
LBJ	graphite twill	+\$0
LBK	pewter mesh	+\$0
LBL	steel mesh	+\$0
LBM	crisp linen	+\$0
LBN	classic linen	+\$0
LBP	casual linen	+\$0
LBQ	white twill	+\$0
LU	soft white	+\$0
MT	medium tone	+\$0
WL	sandstone	+\$0
WN	warm grey neutral	+\$0

Upper Bin *continued*

Step 6. Bin Finish		
MS	metallic silver	+\$5
G1	graphite	+\$0
91	white	+\$0

Step 7. Bin Divider Color		
MS	metallic silver	+\$0
G1	graphite	+\$0
91	white	+\$0
RO	red	+\$30
79	green apple	+\$30
TRQ	turquoise	+\$30
MY3	yellow oxide	+\$30
SG	slate grey	+\$0

Freestanding Bin

BVB1.

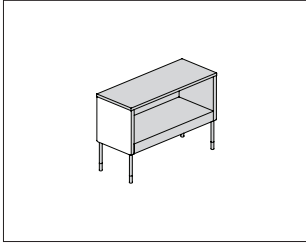

Product Information

Description

This freestanding bin has 4 legs and provides shared storage. It has a laminate, veneer, or Formcoat® work surface with a painted steel understructure bin. It is available with or without power access, with or without doors, and accepts screen attachment. Legs have glides that provide up to 2" of adjustment. Bin divider included.

Notes

The exposed end of the understructure bin requires a desk and bin finishing kit (BVD4.), ordered separately.

To connect to other freestanding bins, order desk and bin ganging plate (BVD5.) separately.

Freestanding bins do not allow power pass-through, but can be ordered with grommets to accommodate power at the top surface.

To bring power to the surface of a freestanding bin with power access, order Logic Mini, Grommet Mount (Y1414.) separately.

Bin divider can be specified in a complementary color.

Grommet color is either graphite or white, matched to the work surface color.

When specifying trivalent chrome (47) leg finish, glide color is predetermined to coordinate with specified bin finish:

- Graphite (G1) bin will have black (BK) glides
- Metallic silver (MS) bin will have fog (63) glides
- White (G1) bin will have folkstone grey (8Q) glides

Dimensions

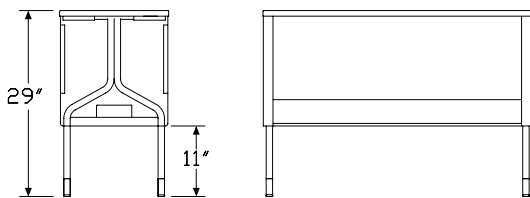
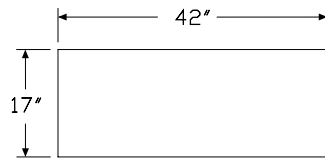

Specification Information

Step 1.

BVB1.

Step 2. Width

29 29" wide
42 42" wide

Step 3. Power Access

P power access
N no power access

Step 4. Bin Doors

D doors
N no doors

Step 5. Top Material

L laminate top/thermoplastic edge
T formcoat®
W veneer

Prices for Steps 1-5.

	DL	DT	DW	NL	NT	NW
BVB1. 29 P	\$1086	1140	1303	943	990	1131
N	\$1000	1050	1200	857	900	1029
42 P	\$1229	1290	1474	1086	1140	1303
N	\$1143	1200	1371	1000	1050	1200

Freestanding Bin *continued*

Step 6. Top Finish

For laminate top/thermoplastic edge (L)

76	light brown walnut	+\$0
8Q	folkstone grey	+\$0
91	white	+\$0
98	studio white	+\$0
CL	cool grey neutral	+\$0
HF	inner tone light	+\$0
HM	natural maple	+\$0
HP	light anigre	+\$0
HT	inner tone	+\$0
HX	aged cherry	+\$0
HY	walnut on cherry	+\$0
LA	light ash	+\$0
LBA	clear on ash	+\$0
LBU	medium matte walnut	+\$0
LBB	oak on ash	+\$0
LBC	walnut on ash	+\$0
LBD	dark brown walnut	+\$0
LBE	medium red walnut	+\$0
LBF	neutral twill	+\$0
LBG	sarum twill	+\$0
LBH	earthen twill	+\$0
LBJ	graphite twill	+\$0
LBK	pewter mesh	+\$0
LBL	steel mesh	+\$0
LBM	crisp linen	+\$0
LBN	classic linen	+\$0
LBP	casual linen	+\$0
LBQ	white twill	+\$0
LM	mahogany	+\$0
LT	light tone	+\$0
LU	soft white	+\$0
MT	medium tone	+\$0
WL	sandstone	+\$0
WN	warm grey neutral	+\$0

For formcoat® (T)

91	white	+\$0
8Q	folkstone grey	+\$0
WL	sandstone	+\$0

For veneer (W)

ET	clear on ash	+\$0
EU	oak on ash	+\$0
EV	walnut on ash	+\$0
2U	light brown walnut	+\$0
40	dark brown walnut	+\$0

Step 7. Edge Finish

For laminate top/thermoplastic edge (L)

76	light brown walnut	+\$0
8Q	folkstone grey	+\$0
8Z	neutral grey	+\$0
91	white	+\$0
98	studio white	+\$0
BU	black umber	+\$0
CL	cool grey neutral	+\$0
HF	inner tone light	+\$0
HM	natural maple	+\$0
HP	light anigre	+\$0
HT	inner tone	+\$0
HX	aged cherry	+\$0
HY	walnut on cherry	+\$0
JB	millwork cherry	+\$0
LA	light ash	+\$0
LBA	clear on ash	+\$0
LBU	medium matte walnut	+\$0
LBB	oak on ash	+\$0
LBC	walnut on ash	+\$0
LBD	dark brown walnut	+\$0
LBE	medium red walnut	+\$0
LBF	neutral twill	+\$0
LBG	sarum twill	+\$0
LBH	earthen twill	+\$0
LBJ	graphite twill	+\$0
LBK	pewter mesh	+\$0
LBL	steel mesh	+\$0
LBM	crisp linen	+\$0
LBN	classic linen	+\$0
LBP	casual linen	+\$0
LBQ	white twill	+\$0
LU	soft white	+\$0
MT	medium tone	+\$0
WL	sandstone	+\$0
WN	warm grey neutral	+\$0

Freestanding Bin *continued*

Step 8. Leg Finish		
91	white	+\$0
G1	graphite	+\$0
MS	metallic silver	+\$10
47	trivalent chrome	+\$150

Step 9. Bin/Bin Doors Finish

For metallic silver (MS)

MS	metallic silver	+\$5
-----------	-----------------	------

For graphite (G1)

G1	graphite	+\$0
-----------	----------	------

For white (91)

91	white	+\$0
-----------	-------	------

For trivalent chrome (47)

91	white	+\$0
G1	graphite	+\$0
MS	metallic silver	+\$5

Step 10. Bin Divider Color

MS	metallic silver	+\$0
G1	graphite	+\$0
91	white	+\$0
RO	red	+\$30
79	green apple	+\$30
TRQ	turquoise	+\$30
MY3	yellow oxide	+\$30
SG	slate grey	+\$0

Step 11. Lock

For doors (D)

KA	keyed alike, black	+\$0
KC	keyed differently, chrome	+\$0
KD	keyed differently, black	+\$0
KQ	keyed alike, chrome	+\$0
NL	no lock	+\$0

Half Bin

BVB2.

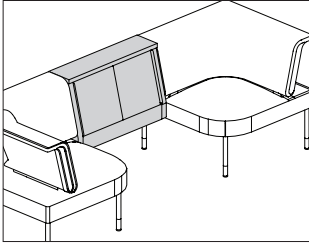

Public Office Landscape® Desking and Storage

Product Information

Description

This bin creates a bridge in group settings that include sectional seating and screens. It has a laminate, veneer, or Formcoat® top surface with a painted steel bin. It comes with doors, and accepts screen attachment. Legs have glides that provide up to 2" of adjustment. Ganging hardware included.

Notes

Half bin must be attached to 2 chairs.

When specifying trivalent chrome (47) leg finish, glide color is predetermined to coordinate with specified bin finish:

- Graphite (G1) bin will have black (BK) glides
- Metallic silver (MS) bin will have fog (63) glides
- White (91) bin will have folkstone grey (8Q) glides

Dimensions

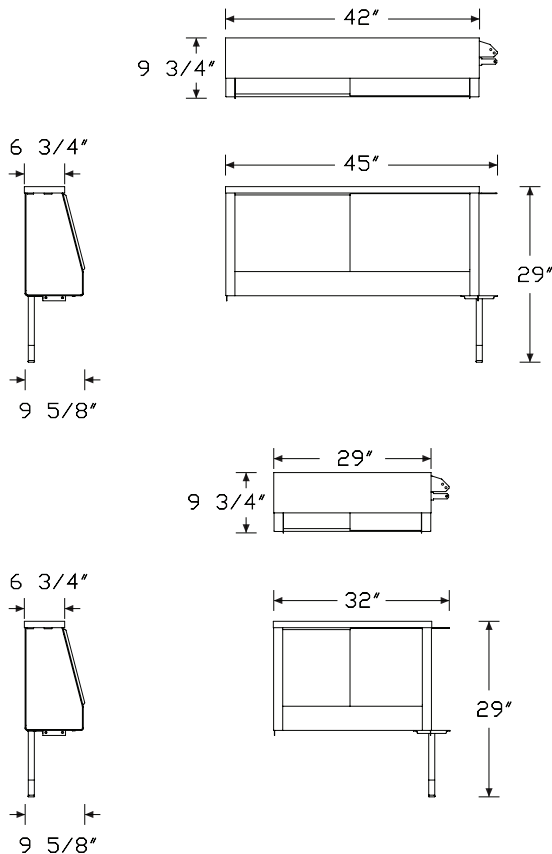

Specification Information

Step 1.

BVB2.

Step 2. Width

- 29** 29" wide
- 42** 42" wide

Step 3. Bin Doors

D doors

Step 4. Leg Option

- N** bin without legs
- L** bin with one shared leg

Step 5. Top Material

- L** laminate top/thermoplastic edge
- T** formcoat®
- W** veneer

Prices for Steps 1-5.

		NL	NT	NW	LL	LT	LW
BVB2.	29 D	\$857	900	1029	914	960	1097
	42 D	\$971	1020	1166	1028	1080	1234

Step 6. Top Finish

For laminate top/thermoplastic edge (L)

76	light brown walnut	+\$0
8Q	folkstone grey	+\$0
91	white	+\$0
98	studio white	+\$0
CL	cool grey neutral	+\$0
HF	inner tone light	+\$0
HM	natural maple	+\$0
HP	light anigre	+\$0
HT	inner tone	+\$0
HX	aged cherry	+\$0
HY	walnut on cherry	+\$0
LA	light ash	+\$0
LBA	clear on ash	+\$0
LBU	medium matte walnut	+\$0
LBB	oak on ash	+\$0
LBC	walnut on ash	+\$0
LBD	dark brown walnut	+\$0
LBE	medium red walnut	+\$0
LBF	neutral twill	+\$0
LBG	sarum twill	+\$0
LBH	earthen twill	+\$0
LBJ	graphite twill	+\$0
LBK	pewter mesh	+\$0
LBL	steel mesh	+\$0
LBM	crisp linen	+\$0
LBN	classic linen	+\$0
LBP	casual linen	+\$0
LBQ	white twill	+\$0
LM	mahogany	+\$0
LT	light tone	+\$0
LU	soft white	+\$0
MT	medium tone	+\$0
WL	sandstone	+\$0
WN	warm grey neutral	+\$0

For formcoat® (T)

91	white	+\$0
8Q	folkstone grey	+\$0
WL	sandstone	+\$0

For veneer (W)

ET	clear on ash	+\$0
EU	oak on ash	+\$0
EV	walnut on ash	+\$0
2U	light brown walnut	+\$0
40	dark brown walnut	+\$0

Step 7. Edge Finish

For laminate top/thermoplastic edge (L)

76	light brown walnut	+\$0
8Q	folkstone grey	+\$0
8Z	neutral grey	+\$0
91	white	+\$0
98	studio white	+\$0
BU	black umber	+\$0
CL	cool grey neutral	+\$0
HF	inner tone light	+\$0
HM	natural maple	+\$0
HP	light anigre	+\$0
HT	inner tone	+\$0
HX	aged cherry	+\$0
HY	walnut on cherry	+\$0
JB	millwork cherry	+\$0
LA	light ash	+\$0
LBA	clear on ash	+\$0
LBU	medium matte walnut	+\$0
LBB	oak on ash	+\$0
LBC	walnut on ash	+\$0
LBD	dark brown walnut	+\$0
LBE	medium red walnut	+\$0
LBF	neutral twill	+\$0
LBG	sarum twill	+\$0
LBH	earthen twill	+\$0
LBJ	graphite twill	+\$0
LBK	pewter mesh	+\$0
LBL	steel mesh	+\$0
LBM	crisp linen	+\$0
LBN	classic linen	+\$0
LBP	casual linen	+\$0
LBQ	white twill	+\$0
LU	soft white	+\$0
MT	medium tone	+\$0
WL	sandstone	+\$0
WN	warm grey neutral	+\$0

Half Bin *continued*

Step 8. Leg Finish

For bin with one shared leg (L)

91	white	+\$0
G1	graphite	+\$0
MS	metallic silver	+\$5
47	trivalent chrome	+\$15

For bin without legs (N)

N	none	+\$0
----------	------	------

Step 9. Bin/Bin Doors Finish

For metallic silver (MS)

MS	metallic silver	+\$5
-----------	-----------------	------

For graphite (G1)

G1	graphite	+\$0
-----------	----------	------

For white (91)

91	white	+\$0
-----------	-------	------

For none (N) or trivalent chrome (47)

91	white	+\$0
G1	graphite	+\$0
MS	metallic silver	+\$5

Step 10. Bin Divider Color

		29	42
MS	metallic silver	+\$0	0
G1	graphite	+\$0	0
91	white	+\$0	0
RO	red	+\$30	45
79	green apple	+\$30	45
TRQ	turquoise	+\$30	45
MY3	yellow oxide	+\$30	45
SG	slate grey	+\$0	0

Desk and Bin Finishing Kit

BVD4.

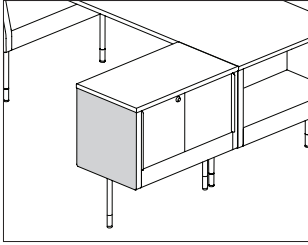

Product Information

Description

This finishing kit is painted steel and covers the exposed end of a desk, peninsula table, connecting bin, or freestanding bin.

Notes

Specify kit color to match color of corresponding desk, peninsula table, connecting bin, or freestanding bin.

Dimensions

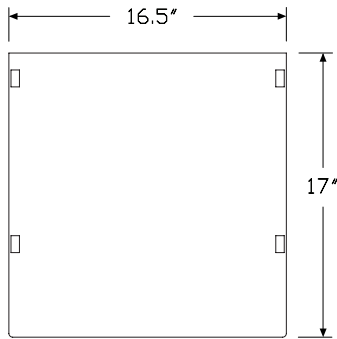

Specification Information

Step 1.

BVD4.

Step 2. Kit Application

- 1 bin finishing kit, single
- 2 bin finishing kit, double

Prices for Steps 1-2.

BVD4. 1	\$49
2	\$85

Step 3. End Cap Material Finish

G1	graphite	+\$0
91	white	+\$0
MS	metallic silver	+\$5

Desk and Bin Ganging Plate

BVD5.

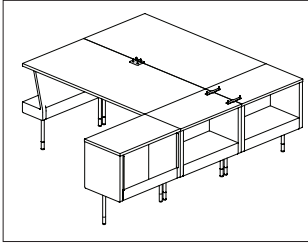

Product Information

Description

These ganging plates provide attachment between bins, desks, and peninsula tables. Attachment hardware included.

Notes

Desk (BVD1.) requires ganging plates (BVD5.C) to attach to other desks or connecting bins.

Connecting bin (BVD2.) requires ganging plates (BVD5.C) to attach to other connecting bins or desks.

Peninsula table (BVT4.) requires ganging plates (BVD5.B) to attach to freestanding bins.

Freestanding bin (BVB1.) requires ganging plates (BVD5.B) to attach to peninsula table or other freestanding bins.

See Planning Guide for more information about settings.

Public Office Landscape® Desking and Storage

Dimensions

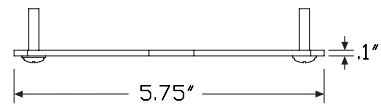

Peninsula table & freestanding bin ganging plates (B)

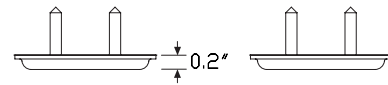
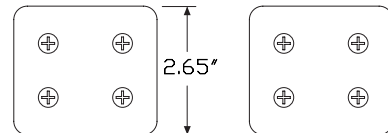
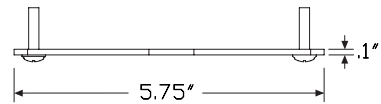

Desk & connecting bin ganging plates (C)

Desk and Bin Ganging Plate

continued

Specification Information

Step 1.

BVD5.

Step 2. Application

B bin-to-bin

C connecting bin ganging kit

Prices for Steps 1-2.

BVD5. B	\$63
C	\$126

Modular Power Entry

BVE01.

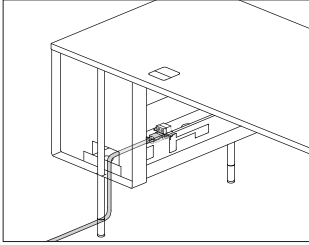

Public Office Landscape® Power

Product Information

Description

This power entry connects a buildings electrical supply from a wall, floor, or column to a desk or connecting bin. It enters through the bottom of the desk or bin. The power entry plugs into any of the ports on the power block and includes a cable that can be field cut to the appropriate length. Cord comes in 6', 10', and 20' lengths. UL listed and Canadian UL listed.

Notes

A licensed electrician must wire power entry.

Dimensions

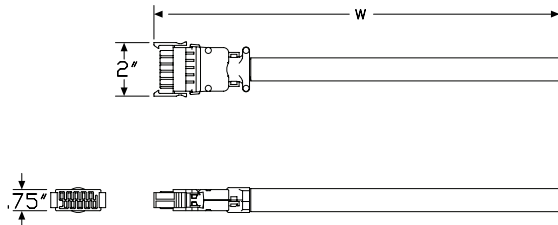

Specification Information

Step 1.

BVE01.

Step 2. Wire Configuration

08 8 wire

Step 3. Cord Length

06 6' long

10 10' long

20 20' long

Prices for Steps 1-3.

	06	10	20
BVE01. 08	\$186	259	360

Modular Power Entry, New York BVE02.

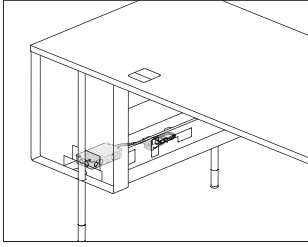

Product Information

Description

This power entry connects a buildings electrical supply from a wall, floor, or column to a desk or connecting bin. It includes a junction box with 8" of wire and a harness. The junction box can be located in the desk or connecting bin. The power entry plugs into any of the ports on the power block. UL listed and Canadian UL listed.

Notes

A licensed electrician must wire power entry.

Dimensions

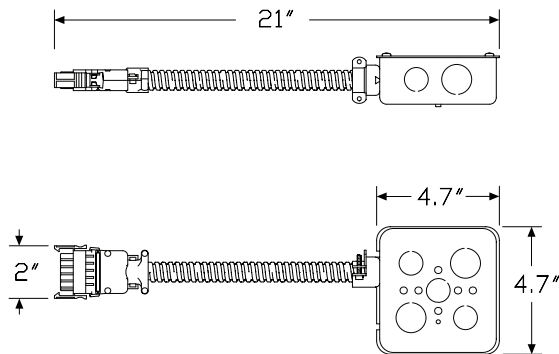

Specification Information

Step 1.

BVE02.

Step 2. Wire Configuration

08 8 wire

Prices for Steps 1-2.

BVE02. 08

\$243

Power Block

BVE03.

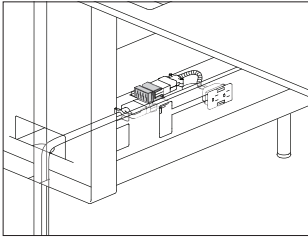

Product Information

Description

This power block has electrical ports for connecting modular power to receptacles and jumpers. It can be located in a desk, preinstalled into the connecting bin, and for power bridge access desk applications can be located in the L-shelf bin. UL listed and Canadian UL listed.

Notes

When using the power bridge desk (BVD1.xxxxB) to power a café table, order the 4 port with receptacle harness (4R) configuration to be installed underneath the L-shelf.

When connecting modular power within connecting bins and desk bins, order the 4 port (04) configuration.

When using the power bridge desk (BVD1.xxxxB) to bring power across desks without a café table configuration between the desks, order the 4 port (04) configuration.

See Planning Guide for more information about power.

Dimensions

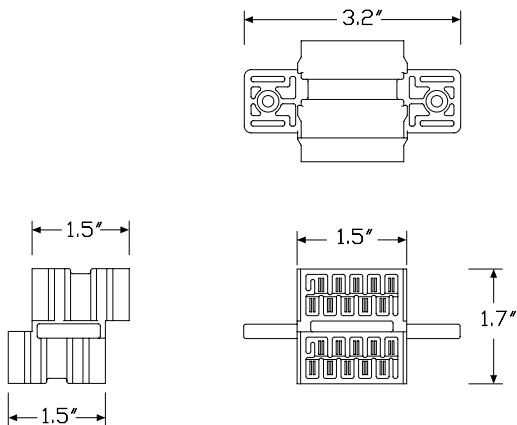

Specification Information

Step 1.

BVE03.

Step 2. Wire Configuration

08 8 wire

Step 3. Block Configuration

04 4 port

4R 4 port with receptacle harness A

Prices for Steps 1-3.

	04	4R
BVE03. 08	\$43	80

Modular Power Duplex

BVE04.

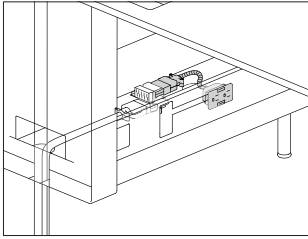

Product Information

Description

This receptacle connects to a power block and provides power to a desk. Package contains 1 duplex receptacle. UL listed and Canadian UL listed.

Notes

When using the power bridge desk (BVD1.xxxxB) to power a café table, order the 8 wire duplex receptacle (FW152) separately.

Dimensions

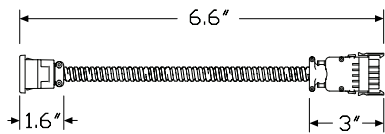

Specification Information

Step 1.

BVE04.

Step 2. Wire Configuration

08 8 wire

Step 3. Duplex Type

- AN** circuit a - shared neutral, 8 wire
- BN** circuit b - shared neutral, 8 wire
- CN** circuit c - shared neutral, 8 wire
- DN** circuit d - shared neutral, 8 wire
- AG** circuit a - shared neutral isolated ground, 8 wire
- BG** circuit b - shared neutral isolated ground, 8 wire
- CG** circuit c - shared neutral isolated ground, 8 wire
- DG** circuit d - shared neutral isolated ground, 8 wire

Prices for Steps 1-3.

	AN	BN	CN	DN	AG	BG	CG	DG
BVE04. 08	\$100	100	100	100	100	100		
BVE04. 08							\$100	100

Step 4. Duplex Color

- 91** white +\$0
- BK** black +\$0

Modular Power Controlled Duplex BVE04M

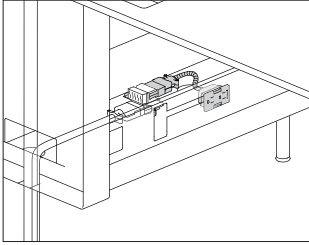

Product Information

Description

This receptacle is to be used for ASHRAE90.1 and Title 24 compliance. A controlled receptacle should be used for any receptacles that are under automated control by the energy management system. The receptacle connects to a power block and provides power to a desk. Package contains 1 duplex receptacle. It is UL listed and Canadian UL listed.

Dimensions

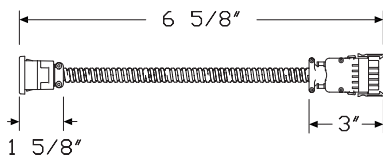

Specification Information

Step 1.

BVE04M.

Step 2. Wire Configuration

08 8 wire

Step 3. Duplex Type

- AN** circuit a - shared neutral, 8 wire
- BN** circuit b - shared neutral, 8 wire
- CN** circuit c - shared neutral, 8 wire
- DN** circuit d - shared neutral, 8 wire
- AG** circuit a - shared neutral isolated ground, 8 wire
- BG** circuit b - shared neutral isolated ground, 8 wire
- CG** circuit c - shared neutral isolated ground, 8 wire
- DG** circuit d - shared neutral isolated ground, 8 wire

Prices for Steps 1-3.

	AN	BN	CN	DN	AG	BG
BVE04M. 08	\$100	100	100	100	100	100
					CG	DG
BVE04M. 08					\$100	100

Step 4. Duplex Color

- 91** white +\$0
- BK** black +\$0

Power Block-to-Power Block Jumper

BVE05.

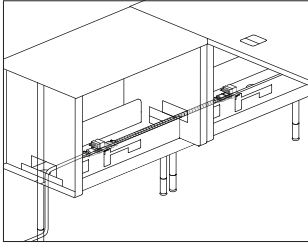

Product Information

Description

This power jumper connects power block to power block in desks and connecting bins. UL listed and Canadian UL listed.

Notes

The 29" jumper distributes power through adjacent desk bin and connecting bin raceways. It connects power blocks in desk back-to-back and offset back-to-back configurations with side-to-side desk bins.

The 52" jumper distributes power through back-to-back desk bin or connecting bin raceways. This jumper includes cover to house jumper outside of the bin.

The 116" jumper distributes power between the power bridge desk (BVD1.xxxxB) in applications where the social chair and/or café table configuration is used in conjunction with the desk.

The 134" jumper distributes power underneath the desk surface of the power bridge desk (BVD1.xxxxB).

See Planning Guide for more information about settings.

Dimensions

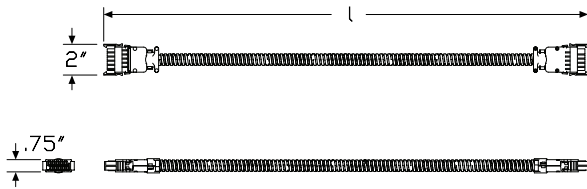

Specification Information

Step 1.

BVE05.

Step 2. Wire Configuration

08 8 wire

Step 3. Jumper Length

29 29" wide

30 52" wide

116 116" wide

134 134" wide

Prices for Steps 1-3.

	29	30	116	134
BVE05. 08	\$100	150	160	180

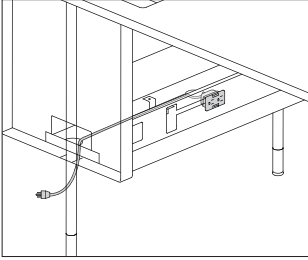

Product Information

Description
 This corded power receptacle provides a plug-in solution in lieu of the modular power system. It plugs directly into a wall or floor outlet. Cord comes in 6', 10', and 20' lengths. Package contains 1 duplex receptacle. UL listed and Canadian UL listed.

Dimensions

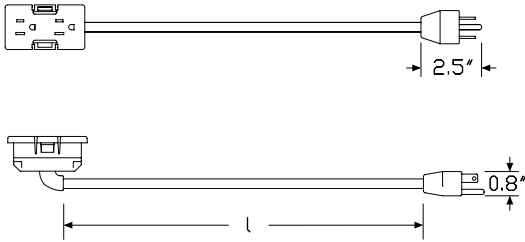

Public Office Landscape® Power

Specification Information

Step 1.

BVE06.

Step 2. Duplex Configuration

1 single duplex

Step 3. Cord Length

06 6' long
10 10' long
20 20' long

Prices for Steps 1-3.

	06	10	20
BVE06. 1	\$91	109	166

Step 4. Duplex Color

91 white +\$0
BK black +\$0

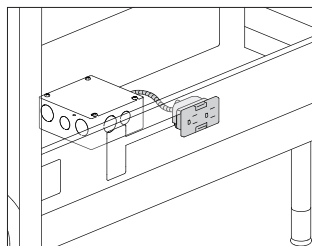

Product Information

Description

This hardwired receptacle connects to the Chicago Power Junction Box and provides power to the desk. Package contains 1 duplex receptacle. UL listed and Canadian UL listed.

Notes

A licensed electrician must wire the receptacle to the junction box (BVEo8.), ordered separately.

Dimensions

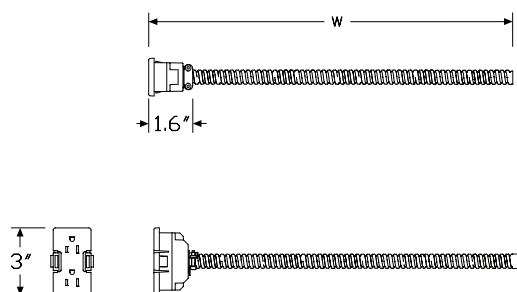

Specification Information

Step 1.

BVE07.

Step 2. Configuration

A circuit a

B circuit b

Prices for Steps 1-2.

BVE07. A	\$100
B	\$100

Step 3. Duplex Color

91 white	+\$0
BK black	+\$0

Chicago Power - Controlled Duplex

BVE07M

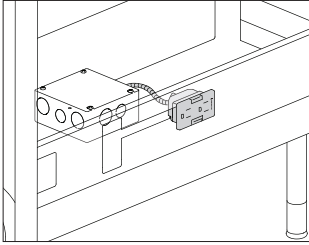

Public Office Landscape® Power

Product Information

Description

This receptacle is to be used for ASHRAE90.1 and Title 24 compliance. A controlled receptacle should be used for any receptacles that are under automated control by the energy management system. This hard-wired receptacle connects to the Chicago power junction box and provides power to a desk. Package contains 1 duplex receptacle. It is UL listed and Canadian UL listed.

Notes

A licensed electrician must wire the receptacle to the junction box (BVEo8.), ordered separately.

Dimensions

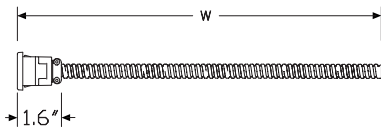

Specification Information

Step 1.

BVE07M. A

Step 2. Configuration

A circuit a A

B circuit b A

Prices for Steps 1-2.

BVE07M. A	\$100
B	\$100

Step 3. Duplex Color

91 white <input type="checkbox"/> A	+ \$0
BK black <input type="checkbox"/> A	+ \$0

Controlled Receptacle Decal
(12 per sheet)

G9999.

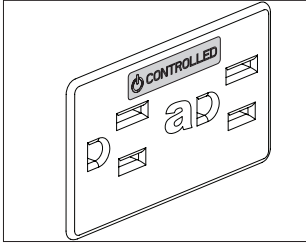

Product Information

Description

This decal is to be used for ASHRAE90.1 and Title 24 compliance. The decal is used to mark standard receptacles (new or existing) that are under automated control by the energy management system. 1 sheet includes 12 clear decals with white or black print.

Dimensions

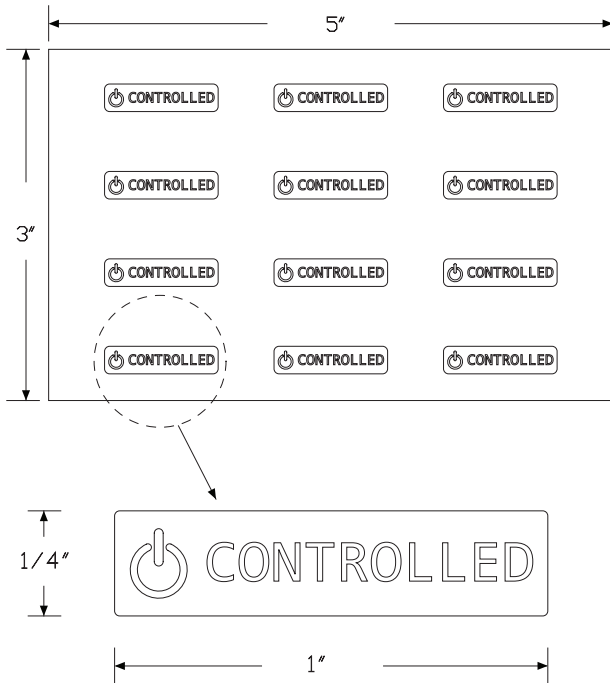

Specification Information

Step 1.

G9999. A

Step 2. Color

B black print A

W white print A

Prices for Steps 1-2.

G9999. B \$7
W \$7

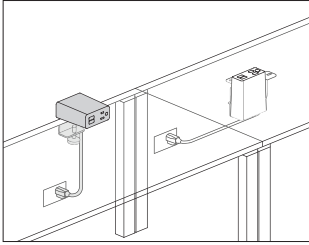

Product Information

Description

This electrical distributor plugs directly into floor, wall, or ceiling drop outlets. Each module configuration presents the same visual appearance. Cable clips and attachment hardware included. Product is UL listed.

Notes

Cable clips for cord management are intended for a 1-time installation. Clamp versions can be reoriented in the field by a technician. A small LED light illuminates through the USB ports when the USB version is plugged in and powered. USB ports provide 10-watt power to charge most devices and tablets at full speed. Cord color is predetermined. For white (G1) finish cords will be white. For graphite (G1) finish cords will be black. Grommet mount attachment (Y1414.xxxG) does not come with the mini grommet. Order Logic mini grommet (Y1412.) separately, as needed.

Public Office Landscape® Power

Dimensions

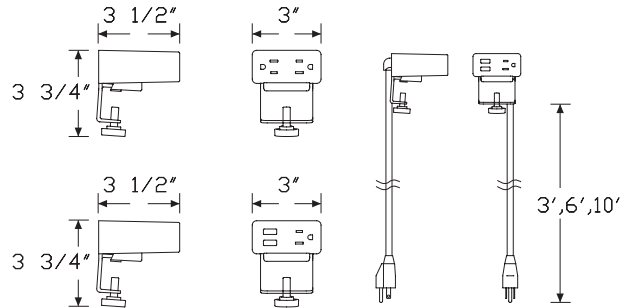

Surface Clamp

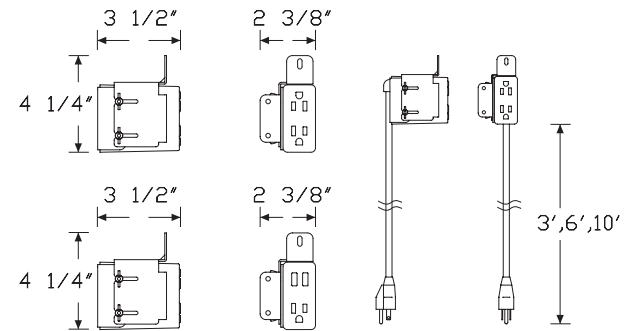

Grommet Mount

Specification Information

Step 1.

Y1414.

Step 2. Configuration

J 1 simplex receptacles, 2 powered USB

K 2 simplex receptacles

Step 3. Cord/Conduit Length

03 3' cord/conduit

06 6' cord/conduit

10 10' cord/conduit

Step 4. Attachment

G grommet mount

S surface clamp

Prices for Steps 1-4.

		G	S
Y1414. J	03	\$332	332
	06	\$332	332
	10	\$342	342
	K 03	\$185	185
	06	\$185	185
	10	\$195	195

Step 5. Finish

91 white +\$0

98 studio white +\$0

G1 graphite +\$0

Logic G1200 Grommet Pass Thru Y1420.

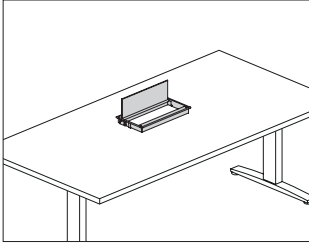

Product Information

Description

This Logic Power Access Solutions™ grommet mounted metal enclosure provides access to cords kept beneath the surface. The unit has an integrated cord keeper.

Notes

Unit size is based on the grommet mounted electrical distributor (Y1425.) with simplex receptacles.

Dimensions

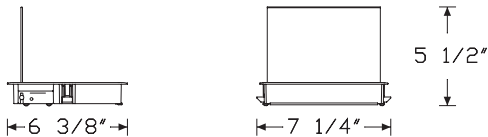

3 outlet opening (T)

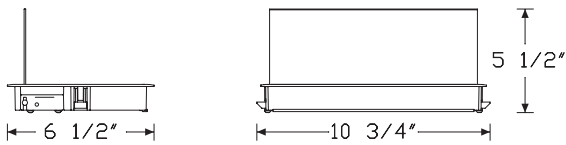

5 outlet opening (V)

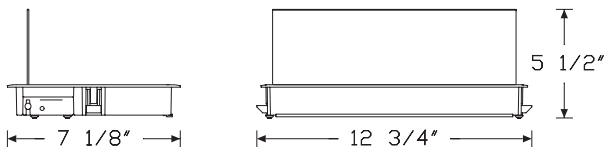

6 outlet opening (X)

Specification Information

Step 1.

Y1420. A

Step 2. Configuration

- T** three outlet opening A
- V** five outlet opening A
- X** six outlet opening A

Prices for Steps 1-2.

Y1420. T	\$214
V	\$235
X	\$255

Step 3. Finish

91 white <input type="checkbox"/> A	+\$0
98 studio white <input type="checkbox"/> A	+\$0
G1 graphite <input type="checkbox"/> A	+\$0
MS metallic silver <input type="checkbox"/> A	+\$0

Chicago Power - Junction Box

BVE08.

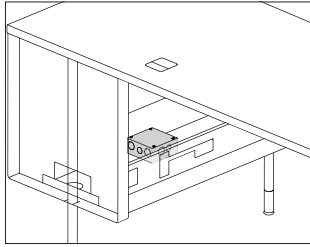

Product Information

Description

This hardwired junction box provides power for up to 2 hardwired Chicago Power Receptacles. UL listed and Canadian UL listed.

Notes

A licensed electrician must wire the junction box to the Chicago power receptacle (BVE07.), ordered separately.

Dimensions

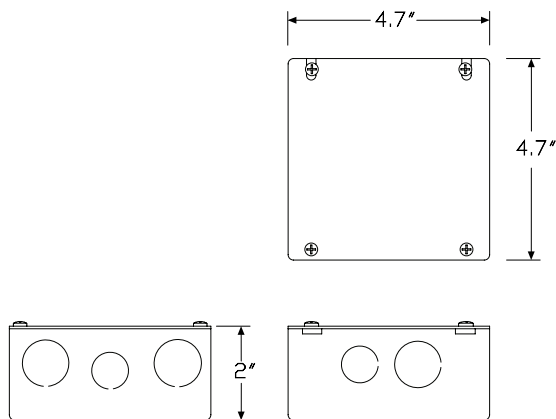

Specification Information

Step 1.

BVE08.

\$71

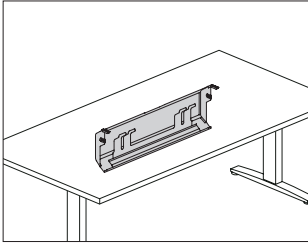

Product Information

Description
 This Logic Power Access Solutions™ stand-alone cable management tray mounts to the underside of most surfaces. It can be used with a Logic unit for cord storage, or used alone with cords routed through the back side of the unit. Tray drops down and holds cords in place while working and can be easily stowed back in place.

Dimensions

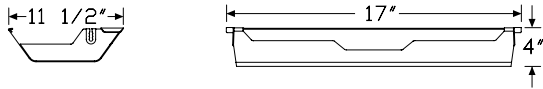

Public Office Landscape® Power

Specification Information

Step 1.

Y1424. A

Step 2. Size

17 17" wide tray A

Prices for Steps 1-2.

Y1424. 17 \$235

Step 3. Finish

- 91** white A +\$0
- 98** studio white A +\$0
- G1** graphite A +\$0
- MS** metallic silver A +\$0

Power Bridge

BVE09.

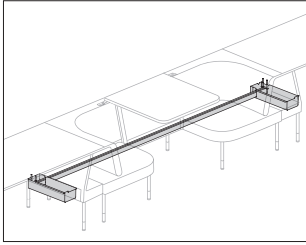

Product Information

Description

This kit includes beam to route power jumper and data between power bridge access desks positioned L-shelf-to-L-shelf with or without social chairs and café table between desk configurations. Attachment hardware included. Power components must be ordered separately.

Notes

Receptacle over only option (NB) supports desk back-to-back configurations with a single or double café and power bridge desk located on left or right side.

Jumper tray only option (00) covers the power block and desk jumper in back-to-back L-shelf configurations with the power bridge desk.

Short bridge option (29) connects L-shelf-to-desk bin configurations with a single social chair between desks. At least 1 desk must be the power bridge desk.

Long bridge option (87) connects L-shelf-to-L-shelf in desk side-to-side configurations with a café table between the power bridge desks.

See Planning Guide for more information about settings.

Dimensions

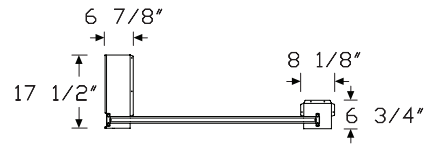

Short Bridge (29)

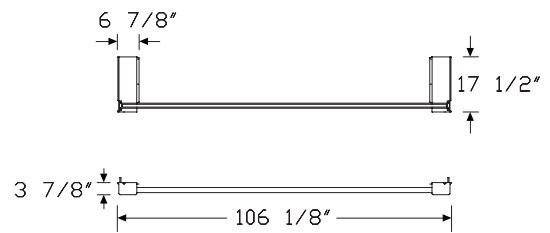

Long Bridge (87)

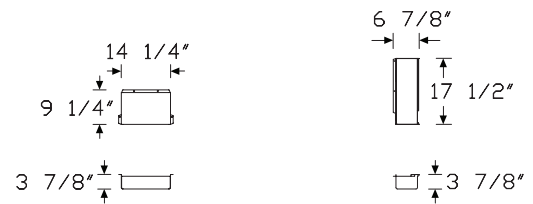

Jumper Tray (00)

Receptacle Cover (NB)

Specification Information

Step 1.

BVE09.

Step 2. Length

- NB** receptacle cover only
- 00** jumper tray only
- 29** short bridge
- 87** long bridge

Step 3. Desk Bin Orientation

For receptacle cover only (NB)

- L** left bin
- R** right bin

For jumper tray only (00), short bridge (29), or long bridge (87)

- B** left bin and right bin

Prices for Steps 1-3.

	B	L	R
BVE09. NB	—	\$120	120
00	\$100	—	—
29	\$450	—	—
87	\$650	—	—

Step 4. Finish

- 91** white +\$0
- G1** graphite +\$0
- MS** metallic silver +\$5

Single Café Table

BVT1.

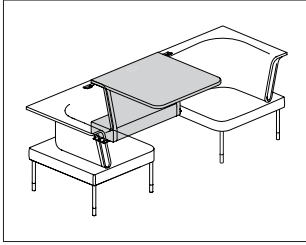

Product Information

Description

This single café table comes with a laminate, veneer, or Formcoat® squared-edge work surface. It has a painted steel shelf, accepts a single 29"-wide screen, and is available with or without power access. Café table includes bag hook. Attachment hardware included.

Notes

Single café table cannot stand alone and must attach between 2 social chairs (BVS1N.).

Power access comes with single grommet to accommodate power at the surface. Grommet color is either graphite or white, matched to the work surface color.

To bring power to the surface of a single café table with power access, order Logic Mini, Grommet Mount (Y1414.) separately.

Bag hook color is matched to shelf color.

Dimensions

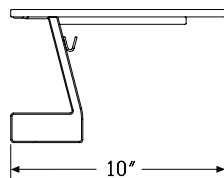
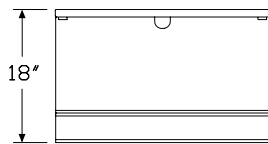
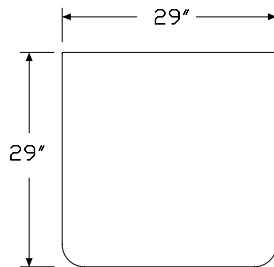

Specification Information

Step 1.

BVT1.

Step 2. Depth

29 29" deep

Step 3. Power Access

P power access

N no power access

Step 4. Top Material

L laminate top/thermoplastic edge

T formcoat®

W veneer

Prices for Steps 1-4.

		L	T	W
BVT1.	29 P	\$857	900	1028
	N	\$807	848	969

Single Café Table *continued*

Step 5. Top Finish

For laminate top/thermoplastic edge (L)

76	light brown walnut	+\$0
8Q	folkstone grey	+\$0
91	white	+\$0
98	studio white	+\$0
CL	cool grey neutral	+\$0
HF	inner tone light	+\$0
HM	natural maple	+\$0
HP	light anigre	+\$0
HT	inner tone	+\$0
HX	aged cherry	+\$0
HY	walnut on cherry	+\$0
LA	light ash	+\$0
LBA	clear on ash	+\$0
LBU	medium matte walnut	+\$0
LBB	oak on ash	+\$0
LBC	walnut on ash	+\$0
LBD	dark brown walnut	+\$0
LBE	medium red walnut	+\$0
LBF	neutral twill	+\$0
LBG	sarum twill	+\$0
LBH	earthen twill	+\$0
LBJ	graphite twill	+\$0
LBK	pewter mesh	+\$0
LBL	steel mesh	+\$0
LBM	crisp linen	+\$0
LBN	classic linen	+\$0
LBP	casual linen	+\$0
LBQ	white twill	+\$0
LM	mahogany	+\$0
LT	light tone	+\$0
LU	soft white	+\$0
MT	medium tone	+\$0
WL	sandstone	+\$0
WN	warm grey neutral	+\$0

For formcoat® (T)

8Q	folkstone grey	+\$0
91	white	+\$0
WL	sandstone	+\$0

For veneer (W)

ET	clear on ash	+\$0
EU	oak on ash	+\$0
EV	walnut on ash	+\$0
2U	light brown walnut	+\$0
40	dark brown walnut	+\$0

Step 6. Edge Finish

For laminate top/thermoplastic edge (L)

76	light brown walnut	+\$0
8Q	folkstone grey	+\$0
8Z	neutral grey	+\$0
91	white	+\$0
98	studio white	+\$0
BU	black umber	+\$0
CL	cool grey neutral	+\$0
HF	inner tone light	+\$0
HM	natural maple	+\$0
HP	light anigre	+\$0
HT	inner tone	+\$0
HX	aged cherry	+\$0
HY	walnut on cherry	+\$0
JB	millwork cherry	+\$0
LA	light ash	+\$0
LBA	clear on ash	+\$0
LBU	medium matte walnut	+\$0
LBB	oak on ash	+\$0
LBC	walnut on ash	+\$0
LBD	dark brown walnut	+\$0
LBE	medium red walnut	+\$0
LBF	neutral twill	+\$0
LBG	sarum twill	+\$0
LBH	earthen twill	+\$0
LBJ	graphite twill	+\$0
LBK	pewter mesh	+\$0
LBL	steel mesh	+\$0
LBM	crisp linen	+\$0
LBN	classic linen	+\$0
LBP	casual linen	+\$0
LBQ	white twill	+\$0
LU	soft white	+\$0
MT	medium tone	+\$0
WL	sandstone	+\$0
WN	warm grey neutral	+\$0

Single Café Table *continued*

Step 7. Shelf Finish		
MS	metallic silver	+\$10
G1	graphite	+\$0
91	white	+\$0

Step 8. Grommet Selection		
<i>For power access (P)</i>		
91	white	+\$0
G1	graphite	+\$0

Focus Café Table

BVT2.

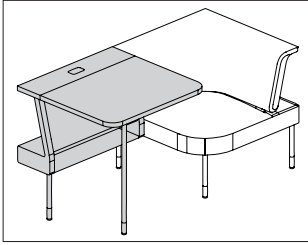

Product Information

Description

The focus café table comes with a laminate, veneer, or Formcoat® squared-edge work surface. It has a painted steel shelf, accepts a single 29"-wide screen, accepts power accessories, and is available with or without power access. Stiffeners, and attachment hardware included.

Notes

Focus café table cannot stand alone and must attach to 1 social chair (BVS1N.).

Power accessories in this application will comply with UL 962A.

Power access comes with single grommet to accommodate power at the surface. Grommet color is either graphite or white, matched to the work surface color.

To bring power to the surface of a focus café table with power access, order Logic Mini, Grommet Mount (Y1414.) separately.

Dimensions

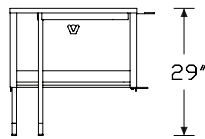
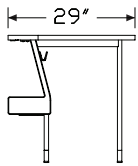
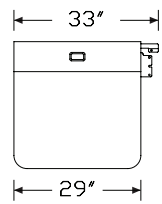

Specification Information

Step 1.

BVT2.

Step 2. Depth

29 29" deep

Step 3. Power Access

P power access

N no power access

Step 4. Surface Application

L table left

R table right

Step 5. Top Material

L laminate top/thermoplastic edge

T formcoat®

W veneer

Prices for Steps 1-5.

		LL	LT	LW	RL	RT	RW
BVT2.	29 P	\$1191	1251	1430	1191	1251	1430
	N	\$1120	1176	1344	1120	1176	1344

Focus Café Table *continued*

Step 6. Top Finish

For laminate top/thermoplastic edge (L)

76	light brown walnut	+\$0
8Q	folkstone grey	+\$0
91	white	+\$0
98	studio white	+\$0
CL	cool grey neutral	+\$0
HF	inner tone light	+\$0
HM	natural maple	+\$0
HP	light anigre	+\$0
HT	inner tone	+\$0
HX	aged cherry	+\$0
HY	walnut on cherry	+\$0
LA	light ash	+\$0
LBA	clear on ash	+\$0
LBU	medium matte walnut	+\$0
LBB	oak on ash	+\$0
LBC	walnut on ash	+\$0
LBD	dark brown walnut	+\$0
LBE	medium red walnut	+\$0
LBF	neutral twill	+\$0
LBG	sarum twill	+\$0
LBH	earthen twill	+\$0
LBJ	graphite twill	+\$0
LBK	pewter mesh	+\$0
LBL	steel mesh	+\$0
LBM	crisp linen	+\$0
LBN	classic linen	+\$0
LBP	casual linen	+\$0
LBQ	white twill	+\$0
LM	mahogany	+\$0
LT	light tone	+\$0
LU	soft white	+\$0
MT	medium tone	+\$0
WL	sandstone	+\$0
WN	warm grey neutral	+\$0

For formcoat® (T)

91	white	+\$0
8Q	folkstone grey	+\$0
WL	sandstone	+\$0

For veneer (W)

ET	clear on ash	+\$0
EU	oak on ash	+\$0
EV	walnut on ash	+\$0
2U	light brown walnut	+\$0
40	dark brown walnut	+\$0

Step 7. Edge Finish

For laminate top/thermoplastic edge (L)

76	light brown walnut	+\$0
8Q	folkstone grey	+\$0
8Z	neutral grey	+\$0
91	white	+\$0
98	studio white	+\$0
BU	black umber	+\$0
CL	cool grey neutral	+\$0
HF	inner tone light	+\$0
HM	natural maple	+\$0
HP	light anigre	+\$0
HT	inner tone	+\$0
HX	aged cherry	+\$0
HY	walnut on cherry	+\$0
JB	millwork cherry	+\$0
LA	light ash	+\$0
LBA	clear on ash	+\$0
LBU	medium matte walnut	+\$0
LBB	oak on ash	+\$0
LBC	walnut on ash	+\$0
LBD	dark brown walnut	+\$0
LBE	medium red walnut	+\$0
LBF	neutral twill	+\$0
LBG	sarum twill	+\$0
LBH	earthen twill	+\$0
LBJ	graphite twill	+\$0
LBK	pewter mesh	+\$0
LBL	steel mesh	+\$0
LBM	crisp linen	+\$0
LBN	classic linen	+\$0
LBP	casual linen	+\$0
LBQ	white twill	+\$0
LU	soft white	+\$0
MT	medium tone	+\$0
WL	sandstone	+\$0
WN	warm grey neutral	+\$0

Focus Café Table *continued*

Step 8. Leg Finish

MS	metallic silver	+\$5
G1	graphite	+\$0
91	white	+\$0

Step 9. Shelf Finish

For metallic silver (MS)

MS	metallic silver	+\$5
-----------	-----------------	------

For graphite (G1)

G1	graphite	+\$0
-----------	----------	------

For white (91)

91	white	+\$0
-----------	-------	------

Step 10. Grommet Selection

For power access (P)

91	white	+\$0
G1	graphite	+\$0

Double Café Table

BVT3.

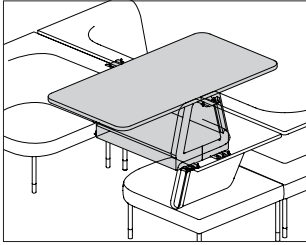

Product Information

Description

This double café table comes with a laminate, veneer, or Formcoat® squared-edge work surface. It has a painted steel shelf and is available with or without power access. Attachment hardware included.

Notes

Double café table cannot stand alone and must attach between 4 social chairs (BVS1N.).

Power access comes with 2 grommets to accommodate power at the surface. Grommet color is either graphite or white, matched to the work surface color.

To bring power to the surface of a double café table with power access, order Logic Mini, Grommet Mount (Y1414.) separately.

Dimensions

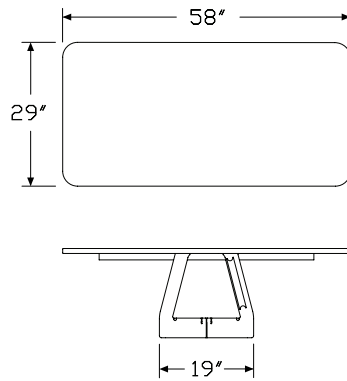

Specification Information

Step 1.

BVT3.

Step 2. Depth

29 29" deep

Step 3. Power Access

P power access

N no power access

Step 4. Top Material

L laminate top/thermoplastic edge

T formcoat®

W veneer

Prices for Steps 1-4.

		L	T	W
BVT3.	29 P	\$1086	1140	1303
	N	\$1000	1050	1200

Double Café Table *continued*

Step 5. Top Finish

For laminate top/thermoplastic edge (L)

76	light brown walnut	+\$0
8Q	folkstone grey	+\$0
91	white	+\$0
98	studio white	+\$0
CL	cool grey neutral	+\$0
HF	inner tone light	+\$0
HM	natural maple	+\$0
HP	light anigre	+\$0
HT	inner tone	+\$0
HX	aged cherry	+\$0
HY	walnut on cherry	+\$0
LA	light ash	+\$0
LBA	clear on ash	+\$0
LBU	medium matte walnut	+\$0
LBB	oak on ash	+\$0
LBC	walnut on ash	+\$0
LBD	dark brown walnut	+\$0
LBE	medium red walnut	+\$0
LBF	neutral twill	+\$0
LBG	sarum twill	+\$0
LBH	earthen twill	+\$0
LBJ	graphite twill	+\$0
LBK	pewter mesh	+\$0
LBL	steel mesh	+\$0
LBM	crisp linen	+\$0
LBN	classic linen	+\$0
LBP	casual linen	+\$0
LBQ	white twill	+\$0
LM	mahogany	+\$0
LT	light tone	+\$0
LU	soft white	+\$0
MT	medium tone	+\$0
WL	sandstone	+\$0
WN	warm grey neutral	+\$0

For formcoat® (T)

8Q	folkstone grey	+\$0
91	white	+\$0
WL	sandstone	+\$0

For veneer (W)

ET	clear on ash	+\$0
EU	oak on ash	+\$0
EV	walnut on ash	+\$0
2U	light brown walnut	+\$0
40	dark brown walnut	+\$0

Step 6. Shelf Finish

MS	metallic silver	+\$10
G1	graphite	+\$0
91	white	+\$0

Step 7. Grommet Selection

For power access (P)

91	white	+\$0
G1	graphite	+\$0

Peninsula Table

BVT4.

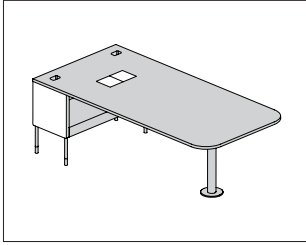

Product Information

Description

This peninsula table comes with a laminate, veneer, or Formcoat® squared-edge work surface. It has a painted steel understructure bin, a column leg, and 2 grommets in the back of the surface. It is available with or without an additional cutout for power access and accepts a single 42"-wide screen. Legs have glides that provide up to 2" of adjustment. Bin divider included.

Notes

To connect peninsula table to other freestanding bins, order desk and bin ganging plate (BVD5.) separately.

Bin divider color is specified separately.

The exposed end of the understructure bin requires a desk and bin finishing kit (BVD4.), ordered separately.

Grommet color is either graphite or white, matched to the work surface color.

To bring power to the surface of a peninsula table with power access, order Logic Mini, Grommet Mount (Y1414.) separately.

Doors are not available for the peninsula table understructure bin.

Dimensions

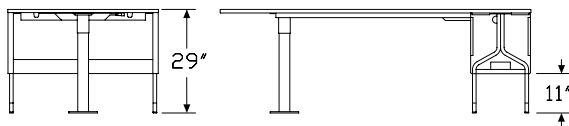
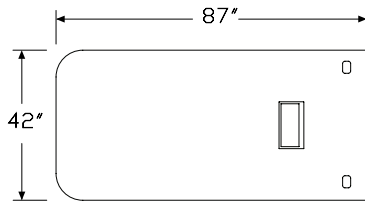

Specification Information

Step 1.

BVT4.

Step 2. Depth

42 42" deep

Step 3. Width

87 87" wide

Step 4. Power Access

N no power access

P power access

Step 5. Doors

N no doors

Step 6. Top Material

L laminate top/thermoplastic edge

T formcoat®

W veneer

Prices for Steps 1-6.

		NNL	NNT	NNW	PNL	PNT	PNW
BVT4.	42 87	\$2429	2550	2914	2429	2550	2914

Step 7. Top Finish

For laminate top/thermoplastic edge (L)

76	light brown walnut	+\$0
8Q	folkstone grey	+\$0
91	white	+\$0
98	studio white	+\$0
CL	cool grey neutral	+\$0
HF	inner tone light	+\$0
HM	natural maple	+\$0
HP	light anigre	+\$0
HT	inner tone	+\$0
HX	aged cherry	+\$0
HY	walnut on cherry	+\$0
LA	light ash	+\$0
LBA	clear on ash	+\$0
LBU	medium matte walnut	+\$0
LBB	oak on ash	+\$0
LBC	walnut on ash	+\$0
LBD	dark brown walnut	+\$0
LBE	medium red walnut	+\$0
LBF	neutral twill	+\$0
LBG	sarum twill	+\$0
LBH	earthen twill	+\$0
LBJ	graphite twill	+\$0
LBK	pewter mesh	+\$0
LBL	steel mesh	+\$0
LBM	crisp linen	+\$0
LBN	classic linen	+\$0
LBP	casual linen	+\$0
LBQ	white twill	+\$0
LM	mahogany	+\$0
LT	light tone	+\$0
LU	soft white	+\$0
MT	medium tone	+\$0
WL	sandstone	+\$0
WN	warm grey neutral	+\$0

For formcoat® (T)

8Q	folkstone grey	+\$0
91	white	+\$0
WL	sandstone	+\$0

For veneer (W)

ET	clear on ash	+\$0
EU	oak on ash	+\$0
EV	walnut on ash	+\$0
2U	light brown walnut	+\$0
40	dark brown walnut	+\$0

Step 8. Edge Finish

For laminate top/thermoplastic edge (L)

76	light brown walnut	+\$0
8Q	folkstone grey	+\$0
8Z	neutral grey	+\$0
91	white	+\$0
98	studio white	+\$0
BU	black umber	+\$0
CL	cool grey neutral	+\$0
HF	inner tone light	+\$0
HM	natural maple	+\$0
HP	light anigre	+\$0
HT	inner tone	+\$0
HX	aged cherry	+\$0
HY	walnut on cherry	+\$0
JB	millwork cherry	+\$0
LA	light ash	+\$0
LBA	clear on ash	+\$0
LBU	medium matte walnut	+\$0
LBB	oak on ash	+\$0
LBC	walnut on ash	+\$0
LBD	dark brown walnut	+\$0
LBE	medium red walnut	+\$0
LBF	neutral twill	+\$0
LBG	sarum twill	+\$0
LBH	earthen twill	+\$0
LBJ	graphite twill	+\$0
LBK	pewter mesh	+\$0
LBL	steel mesh	+\$0
LBM	crisp linen	+\$0
LBN	classic linen	+\$0
LBP	casual linen	+\$0
LBQ	white twill	+\$0
LU	soft white	+\$0
MT	medium tone	+\$0
WL	sandstone	+\$0
WN	warm grey neutral	+\$0

Peninsula Table *continued*

Step 9. Leg Finish		
MS	metallic silver	+\$10
G1	graphite	+\$0
91	white	+\$0

Step 10. Bin/Bin Doors Finish		
-------------------------------	--	--

<i>For metallic silver (MS)</i>		
MS	metallic silver	+\$5

<i>For graphite (G1)</i>		
G1	graphite	+\$0

<i>For white (91)</i>		
91	white	+\$0

Step 11. Bin Divider Color		
MS	metallic silver	+\$0
G1	graphite	+\$0
91	white	+\$0
RO	red	+\$30
79	green apple	+\$30
TRQ	turquoise	+\$30
MY3	yellow oxide	+\$30
SG	slate grey	+\$0

Step 12. Grommet Selection		
91	white	+\$0
G1	graphite	+\$0

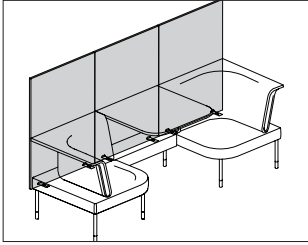

Product Information

Description

Screens attach to social chairs, sectional seats, desks, single café tables, peninsula tables, and freestanding bins. They are tackable, have a single fabric covering the entire screen, and come in 2 widths and 3 heights. Attachment is by a push-button mechanism.

Notes

For attachment to a social chair (BVS1N.), sectional seat (BVS2N.), single café table (BVT1.) and 29" freestanding bin (BVB1.29), specify 29"-wide screen. For attachment to peninsula table (BVT4.) and 42" freestanding bin (BVB1.42), specify 42"-wide screen.

Applications with adjacent screens in a line or at a corner require alignment clip (BVP3.), ordered separately.

Screens accept whiteboard overhang (BVP4.), ordered separately.

Screen accepts Customer's Own Material (COM). Yardage is estimated for nondirectional 54"-wide fabrics.

Height—Yardage

- 42—2.33
- 54—3.09
- 68—3.97

For information on multiple quantities or directional fabrics, contact COM Department. See Order Information in Appendices.

Dimensions

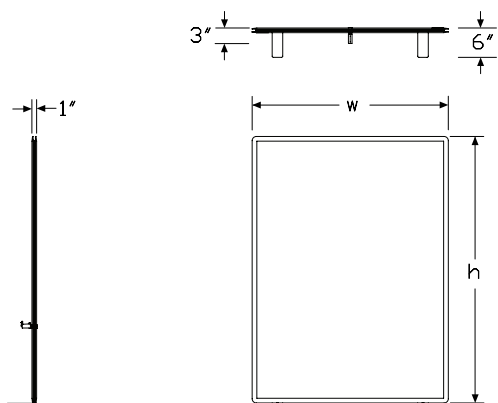

Specification Information

Step 1.

BVP1.

Step 2. Width

- 29 29" wide
- 42 42" wide

Step 3. Height

- 42 42" high
- 54 54" high
- 68 68" high

Step 4. Screen Material

- F fabric

Prices for Steps 1-4.

			F
BVP1.	29	42	\$643
		54	\$829
		68	\$986
	42	42	\$843
		54	\$1029
		68	\$1114

Step 5. Fabric

	42F	54F	68F
Price Category 1	+\$0	0	0
Price Category 2	+\$22	28	36
Price Category 3	+\$50	66	86
Price Category 4	+\$88	110	141

Screen and Desktop Divider Alignment Kit

BVP3.

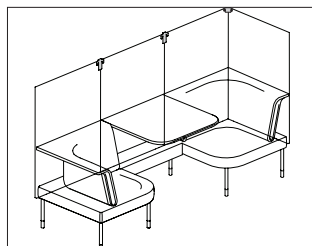

Product Information

Description

This clip comes in 2 types to align screens and desktop dividers either in a line or at a corner. Clip finish is metallic silver (MS).

Notes

For use with the desktop divider (BVP5), only the straight alignment clip is recommended.

Dimensions

Specification Information

Step 1.

BVP3.

Step 2. Application

S straight

C corner

Prices for Steps 1-2.

BVP3. S	\$11
C	\$22

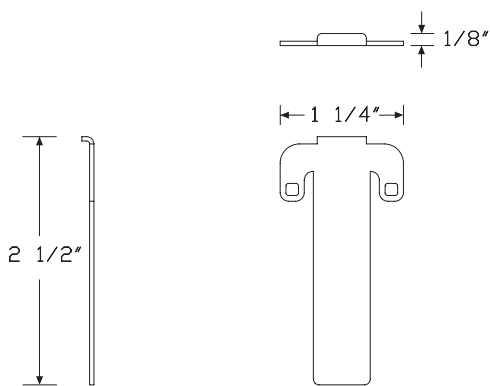

Straight

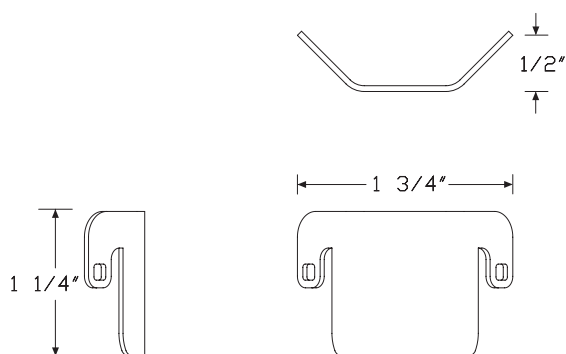

Corner

Whiteboard Overhang

BVP4.

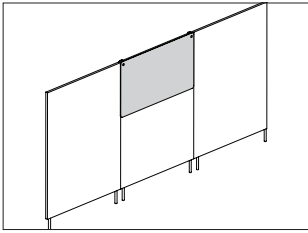

Product Information

Description
 This whiteboard hangs over a screen. It is 25" high when used on 54"-high screens, and 39" high when used on 68"-high screens. Available in 29" and 42" widths to match screen width. Bracket finish is metallic silver (MS).

Notes
 Available for 54"-high and 68"-high screens only.
 A screen can support only a single whiteboard overhang.

Dimensions

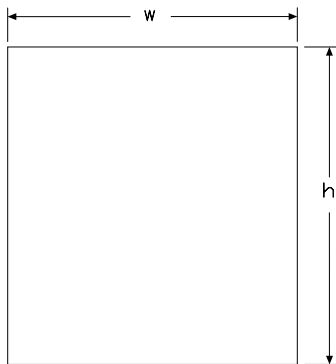

Specification Information

Step 1.

BVP4.

Step 2. Width

- 29 29" wide
- 42 42" wide

Step 3. Height

- 54 54" high
- 68 68" high

Prices for Steps 1-3.

		54	68
BVP4.	29	\$429	571
	42	\$571	714

Desktop Divider

BVP5.

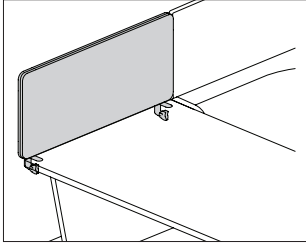

Product Information

Description

This 13"-high fabric-covered divider is mounted to, or freestanding on, desks, tables, and connecting bins. Attachment hardware is included and comes standard in metallic silver (MS) finish.

Notes

Applications with adjacent dividers in a line require alignment clip (BVP3.S), ordered separately.

Divider accepts Customer's Own Material (COM). Yardage is estimated for nondirectional 54"-wide fabrics.

Width—Yardage

29—1.10

58—1.92

For information on multiple quantities or directional fabrics, contact COM Department. See Order Information in Appendices.

Dimensions

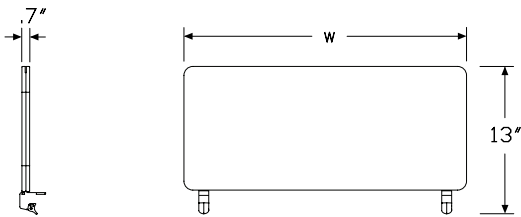

Specification Information

Step 1.

BVP5.

Step 2. Height

13 13" high

Step 3. Width

29 29" wide

58 58" wide

Step 4. Material

F fabric

Step 5. Attachment Location

F freestanding base

S side clamp

Prices for Steps 1-5.

		FF	FS
BVP5.	13 29	\$367	367
	58	\$506	506

Step 6. Fabric

Price Category 1	+\$0
Price Category 2	+\$11
Price Category 3	+\$28
Price Category 4	+\$44

Index by Product Name

Public Office Landscape®	
Chicago Power - Controlled Duplex	page(s) 38
Chicago Power - Duplex	37
Chicago Power - Junction Box	43
Connecting Bin	15
Controlled Receptacle Decal (12 per sheet)	39
Corded Power Solution	36
Desk	12
Desk and Bin Finishing Kit	27
Desk and Bin Ganging Plate	28
Desktop Divider	61
Double Café Table	53
Focus Café Table	50
Freestanding Bin	21
Half Bin	24
Legs	9
Logic G1200 Grommet Pass Thru	42
Logic HD Cable Manager	44
Logic Mini	40
Modular Power Controlled Duplex	34
Modular Power Duplex	33
Modular Power Entry	30
Modular Power Entry, New York	31
Peninsula Table	55
Power Block	32
Power Block-to-Power Block Jumper	35
Power Bridge	45
Screen and Desktop Divider Alignment Kit	59
Screens - Single Material	58
Seat Back Alignment Clip	11
Seat Back Ganging Kit	10
Sectional Seating	7
Single Café Table	47
Social Chair	5
Upper Bin	18
Whiteboard Overhang	60



Index by Product Number

BVB1. Freestanding Bin	page(s) 21
BVB2. Half Bin	24
BVD1. Desk	12
BVD2. Connecting Bin	15
BVD3. Upper Bin	18
BVD4. Desk and Bin Finishing Kit	27
BVD5. Desk and Bin Ganging Plate	28
BVE01. Modular Power Entry	30
BVE02. Modular Power Entry, New York	31
BVE03. Power Block	32
BVE04M Modular Power Controlled Duplex	34
BVE04. Modular Power Duplex	33
BVE05. Power Block-to-Power Block Jumper	35
BVE06. Corded Power Solution	36
BVE07. Chicago Power - Duplex	37
BVE07M Chicago Power - Controlled Duplex	38
BVE08. Chicago Power - Junction Box	43
BVE09. Power Bridge	45
BVP1. Screens - Single Material	58
BVP3. Screen and Desktop Divider Alignment Kit	59
BVP4. Whiteboard Overhang	60
BVP5. Desktop Divider	61
BVS1N. Social Chair	5
BVS2N. Sectional Seating	7
BVS3. Legs	9
BVS4. Seat Back Ganging Kit	10
BVS5. Seat Back Alignment Clip	11
BVT1. Single Café Table	47
BVT2. Focus Café Table	50
BVT3. Double Café Table	53
BVT4. Peninsula Table	55
G9999. Controlled Receptacle Decal (12 per sheet)	39
Y1414. Logic Mini	40
Y1420. Logic G1200 Grommet Pass Thru	42
Y1424. Logic HD Cable Manager	44



20-Day or Less/Assigned Lead-Time Order Information

20-Day or Less and Assigned Lead-Time Programs

20-day or less and assigned lead-time products are designed for established Herman Miller dealers with pre-approved credit.

Products are distributed from multiple manufacturing facilities across the United States. All products and options not designated by an Assigned Lead-Time icon **A** will ship in 20 business days or less after being acknowledged by Herman Miller. Products and options designated by an **A** are on the assigned lead-time program and will ship in 20 days, less than 20 days, or more than 20 days from order acknowledgement.

Ordering Procedure

Please place orders through Order Manager. If this is not available to you, place orders through mail or fax. Verbal purchase orders will not be accepted.

Order Entry fax number for Passage®, 5000 Series, and Meridian® Filing and Storage: (616) 846 9236.

Order Entry fax number for all other products:
(616) 654 3085.

For more information, contact your Customer Care representative at:
(866) 854 3048 EXT 3400.

Shipments and Delivery

Per Herman Miller Terms and Conditions.

Changes and Cancellation

Per Herman Miller Terms and Conditions.



Customer's Own Material Order Information — Workspaces

Customer's Own Material

Program Overview

The Customer's Own Material (COM) program gives you the option of using textiles other than those listed. Herman Miller will test textiles for application to Herman Miller products and will process orders for those with approved COM textiles only. COM textiles are on assigned lead times.

Omni lists an overview of fabrics that have been tested and indicates whether or not they were approved for application to Herman Miller products.

Specific information on the terms and conditions, testing, approval, and ordering process for COM is listed below. Questions about the COM program and requests for assistance may be directed to your COM representative at:

(616) 654 3400

(866) 854 3048 EXT 6543400

Customer's Own Material Warranty

Herman Miller does not warrant COM textiles. COM textiles are tested for application only; they are not tested for performance. The Herman Miller warranty does apply to the underlying products.

Suppliers of COM textiles are responsible for color consistency within commercial tolerances, UV stability, and resistance to soiling and perspiration.

Customer's Own Material Pricing

COM is a Category 1 fabric. There are no application charges for COM fabrics.

Ordering and payment for COM textile yardage are the responsibility of the customer and the textile supplier.

If desired, Herman Miller will purchase COM textiles directly from True Textiles, C.F. Stinson, Luna Textiles, Maharam, and Momentum Textiles to simplify ordering and shipment. For this service, refer to the Supplier Connection program.

Application Note

Herman Miller does not guarantee that Customer's Own Material (COM) fabric patterns will align across panels/tiles or from one screen to the next. We also do not guarantee that COM fabric designs will be positioned consistently in the same location across several panels, tiles, or screens.

COM is not available on panels.

Textile Approval

1. Select a COM textile and a Herman Miller product.
2. If your textile is not listed in Omni, obtain a test number from a COM representative at (616) 654 3400. You can also submit your request within Omni. Please have the following information ready before calling: textile name, number, pattern, and the product you will apply it to.
3. Herman Miller will notify you of approval or disapproval within 4 days from receipt of the test yardage.

Customer's Own Material Order Information — Workspaces

continued

Ordering Products with COM

1. Refer to the specific products to determine the yardage required for COM textiles.
2. If your textile is not listed in Omni, call a COM representative at (616) 654 3400 or (866) 854 3048 EXT 6543400. The representative will assign an identification number for your textile (ID#) and will verify yardage requirements for your order.

Note: Yardage requirements are based on nondirectional, 54"-wide textiles. 66"-wide textiles are needed for application on 60"-wide products. Additional yardage may be needed due to the unique characteristics of a textile.

3. Enter your order on Order Manager in Omni.
4. Upon receipt of your purchase order, Herman Miller will send you a PO acknowledgment.
5. Arrangements must be made for the textiles to be shipped from the supplier to Herman Miller for application to the Herman Miller products. Textiles must be tagged with the assigned identification number and the roll yardage quantity. See Omni for shipping procedures and current shipping addresses or contact a COM representative at (616) 654 3400 or (866) 854 3048 EXT 6543400.

Products will be scheduled for production when COM textiles are received at Herman Miller. Standard lead times in effect at that time will apply.

Note: If textiles are to be purchased directly by Herman Miller through the Supplier Connection program, Herman Miller will handle the ordering and shipping process and will schedule your order for production upon receipt of your purchase order (dependent on textile availability). Refer to the Supplier Connection program for more information.

Supplier Connection

Program Overview

The Supplier Connection program is a service offered by Herman Miller to purchase approved COM textiles directly from True Textiles, C.F. Stinson, Luna Textiles, Maharam, and Momentum Textiles. When you select a textile through this program, Herman Miller will facilitate the ordering, scheduling, and shipment of the textile directly with the supplier.

Suppliers included in the Supplier Connection program keep an active inventory of textiles that are pre-approved for application to Herman Miller products. Pre-approval applies only to the suitability of a textile for manufacturing and application to a Herman Miller product. Omni provides an overview of fabrics that have been tested and indicates whether or not they were approved for application to Herman Miller products.

Specific information on the terms and conditions, testing, approval, and ordering process for the Supplier Connection program is listed below. Questions and requests for assistance may be directed to your COM representative at:

(616) 654 3400
(866) 854 3048 EXT 6543400

Supplier Connection Warranty

Textiles purchased by Herman Miller through the Supplier Connection program are COM and are not warranted by Herman Miller. COM textiles are tested for application only; they are not tested for performance. The Herman Miller warranty does apply to the underlying products.

Suppliers of COM textiles are responsible for color consistency within commercial tolerances, UV stability, and resistance to soiling and perspiration.

Supplier Connection Pricing

Textiles purchased by Herman Miller through the Supplier Connection program are COM. COM is a Category 1 fabric. There are no application charges for COM fabrics.

Payment for textiles purchased by Herman Miller through the Supplier Connection program is the responsibility of the customer or dealer. Herman Miller will invoice the order at the supplier's prices published at the time of the order.

Customer's Own Material Order Information — Workspaces

continued

Textile Approval

1. Refer to Omni to identify the approval status of the textile. If your textile is not listed, contact the COM Department to request testing for application to Herman Miller products.
2. Herman Miller will notify you of approval or disapproval in approximately 4 days from receipt of the test yardage. If the textile is approved, it will be assigned a COM identification number.

Ordering Products with Supplier Connection COM

1. Identify and include the following information on your purchase order:
 - Product number and option
 - Herman Miller's COM identification number
2. Enter your order on Order Manager in Omni.
3. Upon receipt of the purchase order, Herman Miller will process your order and send you a PO acknowledgment. Herman Miller will determine the yardage required to produce your product and will order and schedule for delivery the required textile. Standard lead times in effect at the time the textile is allocated at the supplier will apply to products ordered through this program.



Customer's Own Material/Customer's Own Leather Order Information — Seating

Packaging

Packaging varies according to individual product. A surcharge may be added for special packaging requests. Contact Customer Care for specific information.

Customer's Own Material/Customer's Own Leather

Program Overview

The Customer's Own Material (COM) and Customer's Own Leather (COL) program gives you the option of using textiles other than those listed. Herman Miller will test textiles for application to Herman Miller products and will process orders for those with approved COM/COL textiles only. COM/COL are assigned lead-time textiles.

Omni lists an overview of fabrics and leathers that have been tested and indicates whether or not they were approved for application to Herman Miller products.

Specific information on the terms and conditions, testing, approval, and ordering process for COM/COL is listed below. Questions about the COM/COL program and requests for assistance may be directed to your COM representative at:

(616) 654 3400

(866) 854 3048 EXT 6543400

Customer's Own Material/Customer's Own Leather Warranty

Herman Miller does not warrant COM/COL textiles. COM/COL textiles are tested for application only; they are not tested for performance. The Herman Miller warranty does apply to the underlying products.

Suppliers of COM/COL textiles are responsible for color consistency within commercial tolerances, UV stability, and resistance to soiling and perspiration.

Customer's Own Material/Customer's Own Leather Pricing

COM is a Category 1 fabric. There are no application charges for COM fabrics. COL is a Category 7 textile; refer to prices on specific products to determine the application charge.

Ordering and payment for COM/COL textile yardage are the responsibility of the customer and the textile supplier.

If desired, Herman Miller will purchase COM textiles directly from True Textiles, C.F. Stinson, Luna Textiles, Maharam, and Momentum Textiles to simplify ordering and shipment. For this service, refer to the Supplier Connection program.

Customer's Own Material/Customer's Own Leather Order Information — Seating

continued

Textile Approval

1. Select a COM/COL textile and a Herman Miller product.
2. If your textile is not listed in Omni, obtain a test number from a COM representative at (616) 654 3400. You can also submit your request within Omni. Please have the following information ready before calling: textile name, number, pattern, roll width, and the product you will apply it to.

Additional yardage may be needed due to the unique characteristics of a textile. All package labels must include the words "COM test" or "COL test" and the assigned COM/COL test number.

3. Herman Miller will notify you of approval or disapproval within 4 days from receipt of the test yardage.

Ordering Products with COM/COL

1. Refer to the specific products to determine the yardage required for COM/COL textiles.
2. If your textile is not listed in Omni, call a COM representative at (616) 654 3400 or (866) 854 3048 EXT 6543400. The representative will assign an identification number for your textile (ID#) and will verify yardage requirements for your order. Additional yardage may be needed due to the unique characteristics of a textile.
3. Enter your order on Order Manager in Omni.
4. Upon receipt of your purchase order, Herman Miller will send you a PO acknowledgment.
5. Arrangements must be made for the textiles to be shipped from the supplier to Herman Miller for application to the seating products. Textiles must be tagged with the assigned identification number and the roll yardage quantity. See Omni for shipping procedures and current shipping addresses or contact a COM representative at (616) 654 3400 or (866) 854 3048 EXT 6543400.

Products will be scheduled for production when COM/COL textiles are received at Herman Miller. Standard lead times in effect at that time will apply.

Note: If textiles are to be purchased directly by Herman Miller through the Supplier Connection program, Herman Miller will handle the ordering and shipping process and will schedule your order for production upon receipt of your purchase order (dependent on textile availability). Refer to the Supplier Connection program for more information.

Supplier Connection

Program Overview

The Supplier Connection program is a service offered by Herman Miller to purchase approved COM textiles directly from True Textiles, C.F. Stinson, Luna Textiles, Maharam, and Momentum Textiles. When you select a textile through this program, Herman Miller will facilitate the ordering, scheduling, and shipment of the textile directly with the supplier.

Suppliers included in the Supplier Connection program keep an active inventory of textiles that are pre-approved for application to Herman Miller products. Pre-approval applies only to the suitability of a textile for manufacturing and application to a Herman Miller product. Omni provides an overview of fabrics that have been tested and indicates whether or not they were approved for application to Herman Miller products.

Specific information on the terms and conditions, testing, approval, and ordering process for the Supplier Connection program is listed below. Questions and requests for assistance may be directed to your COM representative at:

(616) 654 3400
(866) 854 3048 EXT 6543400

Supplier Connection Warranty

Textiles purchased by Herman Miller through the Supplier Connection program are COM and are not warranted by Herman Miller. COM textiles are tested for application only; they are not tested for performance. The Herman Miller warranty does apply to the underlying products.

Suppliers of COM textiles are responsible for color consistency within commercial tolerances, UV stability, and resistance to soiling and perspiration.

Customer's Own Material/Customer's Own Leather Order Information — Seating

continued

Supplier Connection Pricing

Textiles purchased by Herman Miller through the Supplier Connection program are COM. COM is a Category 1 fabric. There are no application charges for COM fabrics.

Payment for textiles purchased by Herman Miller through the Supplier Connection program is the responsibility of the customer or dealer. Herman Miller will invoice the order at the supplier's prices published at the time of the order.

Textile Approval

1. Refer to Omni to identify the approval status of the textile. If your textile is not listed, contact the COM Department to request testing for application to Herman Miller products.
2. Herman Miller will notify you of approval or disapproval in approximately 4 days from receipt of the test yardage. If the textile is approved, it will be assigned a COM identification number.

Ordering Products with Supplier Connection COM

1. Identify and include the following information on your purchase order:
 - Product number and option
 - Herman Miller's COM identification number
2. Enter your order on Order Manager in Omni.
3. Upon receipt of the purchase order, Herman Miller will process your order and send you a PO acknowledgment. Herman Miller will determine the yardage required to produce your product and will order and schedule for delivery the required textile. Standard lead times in effect at the time the textile is allocated at the supplier will apply to products ordered through this program.



Proprietary Textiles Application Chart — Workspaces

• Available

A Assigned lead-time textile.

See following page for exception notes.

	Action Office® Panels/Connectors	Action Office/Ethospace® B-Style Storage	Action Office B-Style Tackboards	Action Office/Ethospace E-Style Storage	Ethospace Tiles/Connectors	Ethospace Work Surface-Attached Screens	Ethospace/Canvas Office Landscape® Privacy Doors	Exclave® Tackable Boards and Stowage Tackable Backdrop	Exclave Video-Friendly Tackable Boards and Stowage Tackable Backdrop	Canvas Tiles/Extended Width Tiles	Canvas B-/E-Style Storage	Canvas Standing Screen and Team Wall Infill	Canvas Tackboards	Layout Studio® Framed Screen	Locale® Display Tackboard	Locale Freestanding Screen and Workbase Screen	Locale L-Desk/D-Desk Screens	Parit™ Screens/Flat Edge Screens	Public Office Landscape® Screen/Desk Top Divider	Renew™ Link Screens	Resolve® Boundary Screens/Flags	Resolve Display Screens	Resolve Rolling Screens/Canopies	Thrive® Personal Side Screen	5000 Series Storage and Tackboards	Tu® Wood Storage Cubby Tackboard	Seating
Price Category 1																											
COM Customers Own Material A	1	1	1	1	1	1	1	1	1	1	1	1	1	1	1	1	1	1	1	1	1	1	1	1	1	1	1
8A__ Bubbletack™																											
2V__ Chain	•	•	•	•	•	•	•	•	•	•	•	•	•	•	•	•	•	•	•	•	•	•	•	•	•	•	•
8T__ Crossing (85__)	2	2	2	•	•	•	•	•	•	•	•	•	•	•	•	•	•	•	•	•	•	•	•	•	•	•	•
95__ Gem	2	2	2	•	•	•	•	•	•	•	•	•	•	•	•	•	•	•	•	•	•	•	•	•	•	•	•
2I__ Grasscloth	•	•	•	•	•	•	•	•	•	•	•	•	•	•	•	•	•	•	•	•	•	•	•	•	•	•	•
1MN__ Monologue	2	2	2	•	•	•	•	•	•	•	•	•	•	•	•	•	•	•	•	•	•	•	•	•	•	•	•
8B__ Multiscrim™						•																					
5T__ Resonance	•	•	•	•	•	•	•	•	•	•	•	•	•	•	•	•	•	•	•	•	•	•	•	•	•	•	•
8C__ Scrim Trim																											
2M__ Silkworm	•	•	•	•	•	•	•	•	•	•	•	•	•	•	•	•	•	•	•	•	•	•	•	•	•	•	•
22F__ Slant	6	•	•	•	•	•	•	•	•	•	•	•	•	•	•	•	•	•	•	•	•	•	•	•	•	•	•
Price Category 2																											
3P__ ColorGuard		2	•																								•
51__ Cord	•	•	•	•	•	•	•	•	•	•	•	•	•	•	•	•	•	•	•	•	•	•	•	•	•	•	•
92__ Crepe	2	•	•	•	•	•	•	•	•	•	•	•	•	•	•	•	•	•	•	•	•	•	•	•	•	•	•
57__ Frost	•	•	•	•	•	•	•	•	•	•	•	•	•	•	•	•	•	•	•	•	•	•	•	•	•	•	•
84__ Grosgrain	4			•	•	•	•	•	•	•	•	•	•	•	•	•	•	•	•	•	•	•	•	•	•	•	•
4N__ Horizon	2	2	2	•	•	•	•	•	•	•	•	•	•	•	•	•	•	•	•	•	•	•	•	•	•	•	•
1LM__ Loom	2	2	2	•	•	•	•	•	•	•	•	•	•	•	•	•	•	•	•	•	•	•	•	•	•	•	•
1HA__ Medley	2	2	2	•	•	•	•	•	•	•	•	•	•	•	•	•	•	•	•	•	•	•	•	•	•	•	•
3A__ Moiré		2	2	•	•	•	•	•	•	•	•	•	•	•	•	•	•	•	•	•	•	•	•	•	•	•	•
43__ Tape																											
8R__ Twist (5S__)	5	2	2	•	•	•	•	•	•	•	•	•	•	•	•	•	•	•	•	•	•	•	•	•	•	•	•
Price Category 3																											
70__ Bento	2	2	2	•		•				•	2	•	•	•	•	•	•	•	•	•	•	•	•	•	•	•	•
1FB__ Connection	•	•	•	•	•	•	•	•	•	•	•	•	•	•	•	•	•	•	•	•	•	•	•	•	•	•	•
1FC__ Current	•	•	•	•	•	•	•	•	•	•	•	•	•	•	•	•	•	•	•	•	•	•	•	•	•	•	•
8Z__ Glaze	•	•	•	•	•	•	•	•	•	•	•	•	•	•	•	•	•	•	•	•	•	•	•	•	•	•	•
47__ Ground Cloth®	•	•	•	•	•	•	•	•	•	•	•	•	•	•	•	•	•	•	•	•	•	•	•	•	•	•	•
5D__ Kira 2	2	2	2	•	•	•	•	•	•	•	2	•	•	•	•	•	•	•	•	•	•	•	•	•	•	•	•
8L__ Savannah	•	20	•	•	•	•	•	•	•	•	•	•	•	•	•	•	•	•	•	•	•	•	•	•	•	•	•
8U__ Stitches (5Z__)		2	2	•																							
8W__ Strands	•	•	•	•	•	•	•	•	•	•	•	•	•	•	•	•	•	•	•	•	•	•	•	•	•	•	•

continued on next page

Proprietary Textiles Application Chart — Workspaces

continued

	Action Office® Panels/Connectors	Action Office/Ethospace® B-Style Storage	Action Office B-Style Tackboards	Action Office/Ethospace E-Style Storage	Ethospace Tiles/Connectors	Ethospace Work Surface-Attached Screens	Ethospace/Canvas Office Landscape® Privacy Doors	Exclave® Tackable Boards and Stowage Tackable Backdrop	Exclave Video-Friendly Tackable Boards and Stowage Tackable Backdrop	Canvas Tiles/Extended Width Tiles	Canvas B-/E-Style Storage	Canvas Standing Screen and Team Wall Infill	Canvas Tackboards	Layout Studio® Framed Screen	Locale® Display Tackboard	Locale Freestanding Screen and Workbase Screen	Locale L-Desk/D-Desk Screens	Pari™ Screens/Flat Edge Screens	Public Office Landscape® Screen/Desk Top Divider	Renew™ Link Screens	Resolve® Boundary Screens/Flags	Resolve Display Screens	Resolve Rolling Screens/Canopies	Thrive® Personal Side Screen	5000 Series Storage and Tackboards	Tu® Wood Storage Cubby Tackboard	Seating
Price Category 4																											
2X__ Glisten	•	•	•	•	•		•			•	•	•	•	•	•					•					•	•	
6S__ Quilty	2	2	2	•	•		•			•	2	•	•	•	•										3	•	•
63__ Sironetta	•	•	•	•	•		•			•	•	•	•	•	•	•		•	•					•	3	•	•
Price Category 5																											
No fabrics available at this time.																											
Price Category 6																											
No fabrics available at this time.																											

- 1 Refer to price book appendices and Kiosk for COM information. COM not available on panels.
- 2 Available on all products except 54" and 60" wide.
- 3 Fabric is railroaded for all widths.
- 4 Not available on Action Office (AO) acoustical panels.
- 5 (8R__), (8T__), (85__), and (5S__) not available on AO acoustical panels and not available on 54"- or 60"-wide products.
- 6 Not available on Action Office (AO) connectors, cable management, and spacers.
- 8 Available in select colors. See the "Proprietary Textile Colors — Seating" appendix.
- 14 Not available on Resolve flags.
- 15 Fabric is railroaded for all widths, except on Passage full-height screens.
- 16 Not available on Passage full-height screens. Fabric is railroaded for all widths.
- 18 Available on seating products in select colors. See the "Proprietary Textile Colors — Seating" appendix.
- 19 Not available in Grosgrain (84__) fabric colors 8401, 8405, and 8413.
- 20 Available only on Ethospace B-Style.
- 22 Not available as railroaded application option for Chain and Moire on Canvas extended width tiles.
- 24 Not available on Ethospace cable access tile, cable channel tile, or beltline face tile.

Application Note: Herman Miller cannot guarantee material/pattern alignment in adjacent products. For example, a fabric's pattern may not align from one screen to the next, or from one panel to the next.

Proprietary Textile Colors – Workspaces

Price Category 1

Customer's Own Material
See Order Information in
Appendices.
Assigned lead-time textile. A

Bubbletack™
100% polyester

8A01	Seashell White
8A02	Pearl Grey
8A05	Dune Beige
8A07	Pebble Beige
8A09	Olive Green
8A13	Slate Purple
8A19	Spa Blue
8A24	Sable Grey
8A27	Summer White
8A28	Moth Grey
8A29	Tea Leaf Grey
8A30	Blue Grey
8A31	Dusty Bronze
8A32	Slate Blue
8A33	Caramel Beige
8A34	Kiwi Green
8A35	Studio White
8A36	Blush Grey
8A37	Shale
8A38	Slate
8A39	Eggnog
8A40	Persimmon
8A41	Bud

Chain
66" wide
100% recycled polyester

2V01	Pearl
2V02	Oyster
2V03	Wheat
2V04	Linen
2V05	Wicker
2V06	Bamboo
2V07	Sage
2V08	Spring Wood
2V09	Iceberg

Crossing
54" wide
86% antimony-free polyester
14% polyester

8T03	Wicker *
8T04	Porcelain *
8T05	Warm Grey *
8T06	Sepia
8T07	Pumpkin
8T08	Copper
8T09	Cranberry
8T10	Tomato
8T11	Mulberry
8T12	Plum
8T13	Green Apple
8T14	Loden
8T15	Spruce
8T16	Periwinkle
8T17	Cerulean
8T18	Indigo
8T19	Shale *
8T20	Brownstone
8T21	Bark
8T22	Tin *
8T23	Graphite
8T24	Black

Crossing
For systems products only.
54" wide
86% antimony-free polyester
14% polyester

8501	Ivory *
8502	Oyster *

* Crossing colors available on
Exclave® Video-friendly Tackable
Boards and Stowage Tackable
Backdrop

Gem
54" wide
100% antimony-free polyester

9501	Sesame
9502	Tangerine
9503	Red
9504	Red Violet
9505	Mulberry
9506	Java
9507	Twilight
9508	Bayou
9509	Iris
9510	Berry Blue
9511	Aqua Green
9512	Green Apple
9513	Spruce
9514	Black
9515	Slate Grey
9516	Fog

Grasscloth
66" wide
100% recycled polyester

2I01	Silver Birch
2I02	Pampas
2I03	Sedge
2I07	Lea
2I08	Taro
2I09	Steam Grey
2I10	Cayenne
2I11	Bottle Green
2I12	Surf
2I13	Gravel

Monologue
54" wide
56% recycled polyester
44% polyester

1MN01	Linen
1MN02	Alabaster
1MN03	Truffle
1MN04	Folkstone
1MN05	Silver Pine
1MN06	Slate
1MN07	Seed
1MN08	Yellow Oxide
1MN09	Persimmon
1MN10	Tundra
1MN11	Meadow
1MN12	Blue Sky
1MN13	Blue Spruce
1MN14	Deep Sea

Multiscrim™
60" wide
100% polyester

8B01	Seashell White
8B02	Pearl Grey
8B05	Dune Beige
8B07	Pebble Beige
8B09	Olive Green
8B15	Slate Purple
8B19	Spa Blue
8B24	Sable Grey
8B27	Summer White
8B28	Moth Grey
8B29	Tea Leaf Grey
8B30	Blue Grey
8B31	Dusty Bronze
8B32	Slate Blue
8B33	Caramel Beige
8B34	Kiwi Green
8B35	Studio White
8B36	Blush Grey
8B37	Shale
8B38	Slate
8B39	Eggnog
8B40	Persimmon
8B41	Bud

Price category 1 continued on
next page

Proprietary Textile Colors — Workspaces

continued

Price Category 1

continued

Resonance

66" wide	
100% polyester	
5T04	Greige
5T05	Porcelain
5T06	Alabaster
5T15	Iris
5T28	Sugar
5T47	Tobacco
5T54	Saltbush
5T57	Seed
5T58	Sepia
5T59	Tundra
5T60	Iceberg
5T61	Black
5T62	Chamois
5T63	Citrus
5T64	Tangerine
5T65	Red
5T66	Wild Berry
5T67	Boysenberry
5T68	Pistachio
5T69	Green Apple
5T70	Forest
5T71	Jade
5T72	Blue Green
5T73	Bright Turquoise
5T74	Twilight

Scrim Trim

61" wide	
82% polyester	
18% spandex	
8C01	Seashell White
8C02	Pearl Grey
8C22	Winter Grey
8C24	Sable Grey

Silkworm

66" wide	
58% recycled polyester	
42% polyester	
2M01	Cocoon
2M02	Pongee
2M03	Saffron
2M04	Tussah
2M05	Ceylon
2M06	Jasmine
2M07	Shale
2M08	Monsoon

Slant

66" wide	
51% polyester	
49% recycled polyester	
22F01	Beech Nut
22F02	Chamois
22F03	Chartreuse
22F04	Pesto
22F05	Peacock
22F06	Neptune
22F07	Blueberry
22F08	Boysenberry
22F09	Magenta
22F10	Pumpkin
22F11	Cranberry
22F12	Silver Birch
22F13	Bluestone
22F14	Truffle
22F15	Shale

Price Category 2

ColorGuard

54" wide	
100% vinyl	
3P01	Grey
3P02	Navy
3P03	Spruce ^A
3P08	Blueberry ^A
3P12	Black Plum ^A
3P14	Black
3P19	Slate
3P31	Horizon Blue ^A
3P33	Pumice
3P54	Candy Apple ^A
3P72	Allspice ^A
3P96	Manzanita ^A
3P97	Fudge ^A
3PB2	Sea Grass ^A
3PB5	Vizcaya Palm ^A
3PB9	Neptune ^A
3PC7	Bucksuede ^A
3PD4	Otter ^A

^A Assigned lead-time color.

Cord

66" wide	
51% antimony-free polyester	
49% polyester	
5101	Ivory
5102	White Ash
5103	Linen
5104	Bamboo
5105	Sepia
5106	Wicker
5107	Sesame
5108	Kiwi Green
5109	Bayou
5110	Shade
5111	Spring Wood
5112	Summer White

Crepe

54" wide	
100% recycled polyester	
9201	Licorice
9203	Smoke
9207	Cherry
9209	Claret
9212	Raisin
9218	Aquamarine
9223	Cadet
9241	Beachglass
9243	Midnight
9244	Artichoke
9248	Warm White *
9249	Stone *
9250	Earth
9251	Fog *
9252	Slate Grey
9253	Yellow Dark
9254	Coral
9255	Blush Grey *
9256	Wild Berry
9257	Clover
9258	Caribbean
9259	Cerulean
9260	Brownstone
9261	Shale
9262	Graphite
9263	Tomato
9264	Green Apple

* Crepe colors available on Exclave® Video-friendly Tackable Boards and Stowage Tackable Backdrop

Price category 2 continued on next page

Proprietary Textile Colors — Workspaces

continued

Price Category 2

continued

Frost	
66" wide	
100% recycled polyester	
5701	Bisque
5702	Abalone
5703	Porcelain
5704	Honey
5705	Iceberg
5706	Sage
5707	Reed
5708	Steam Grey
5709	Gunmetal
5710	Sable Grey

Grosgrain	
66" wide	
100% recycled polyester	
8401	Pearl * **
8402	White Ash
8403	Warm Grey
8404	Khaki
8405	Oyster *
8406	Celadon
8407	Chamois
8408	Spa Blue
8409	Bud
8410	Kiwi Green
8411	Bayou
8412	Tin
8413	Iceberg *

* Grosgrain colors not available on Canvas Dock Mounted Screens, Locale® Workbase Screen, Public Office Landscape® Screen/Desk Top Divider, and Thrive® Personal Side Screen.
 ** Color not available on Canvas tiles.

Horizon	
54" wide	
65% antimony-free polyester	
35% polyester	
4N01	Rye Grass
4N02	Sugar Pine
4N03	Silver Pine
4N04	White Ash
4N05	Spring Wood
4N06	Tamarack
4N07	Mushroom
4N08	Haystack
4N09	Oat Grass
4N10	Forest Moss
4N11	Hickory
4N12	Beech Nut
4N13	Pine Cone
4N14	Poplar
4N15	Elderberry

Loom	
54" wide	
100% polyester	
1LM01	Linen
1LM02	Brown Sugar and Spice
1LM03	Brick and Mortar
1LM04	Salt and Pepper
1LM05	Black
1LM06	Lemongrass
1LM07	Poppy
1LM08	Wild Berry
1LM09	Loden
1LM10	Jade
1LM11	Deep Sea

Medley	
54" wide	
100% polyester	
1HA01	Stone *
1HA02	Trail
1HA03	Charcoal
1HA04	Cinder
1HA05	Citrus
1HA06	Papaya
1HA07	Chutney
1HA08	Tundra
1HA09	Feather Grey *
1HA10	Chartreuse
1HA11	Loden
1HA12	Peacock
1HA13	Bayou *
1HA14	Blue Grotto
1HA15	Blueberry
1HA22	Khaki
1HA23	Pewter
1HA24	Yellow Oxide
1HA25	Vintage Rose
1HA26	Raspberry
1HA27	Acai Berry

* Colors available on Exclave®
 Stowage Video-friendly
 Tackable Backdrop

Moiré	
54" wide	
100% recycled polyester	
3A01	Concrete
3A02	Biscotti
3A03	Rattan
3A04	Chambray
3A05	Fern
3A08	Violet
3A09	Zin
3A10	Curry
3A11	Spice
3A12	Cork

Tape	
66" wide	
52% polypropylene	
48% recycled polyester	
4301	Pearl
4302	Oyster
4303	Wicker
4304	Reed
4306	Celadon
4307	Alabaster
4308	Bamboo
4309	Feather Grey
4310	Iceberg

Twist	
54" wide	
80% antimony-free polyester	
13% recycled polyester	
7% polyester	
8R05	Wicker
8R10	Poppy
8R14	Tin
8R15	Shale
8R16	Graphite
8R17	Birch
8R18	Sepia
8R22	Blueberry
8R23	Green Apple
8R26	Gunmetal
8R27	Cinder
8R28	Citrus
8R29	Pekoe
8R30	Tangerine
8R31	Red Plum
8R32	Wisteria
8R33	Forest
8R34	Jade Dark
8R35	Waterfall
8R36	Midnight Blue
8R37	Carbon Dark

Price category 2 continued on next page

Proprietary Textile Colors — Workspaces

continued

Price Category 2

continued

Twist	
For systems products only.	
54" wide	
80% antimony-free polyester	
13% recycled polyester	
7% polyester	
5S01	Pearl
5S02	Ivory
5S03	Oyster

Price Category 3

Bento	
54" wide	
100% antimony-free polyester	
7001	Frost
7002	Linen
7003	Khaki
7004	Truffle
7005	Grey Black
7006	Pumpkin
7007	Cranberry
7008	Everglade
7009	Cobalt

Connection	
66" wide	
100% antimony-free polyester	
1FB1	Oyster
1FB2	Linen
1FB3	Iceberg
1FB4	Silver Pine
1FB5	Apricot
1FB6	Cumin
1FB7	Green Apple
1FB8	Slate Blue
1FB9	Metal

Current	
66" wide	
100% antimony-free polyester	
1FC1	Oyster
1FC2	Linen
1FC3	Iceberg
1FC4	Silver Pine
1FC5	Apricot
1FC6	Cumin
1FC7	Green Apple
1FC8	Slate Blue
1FC9	Metal

Glaze	
66" wide	
100% recycled polyester	
8Z01	Wicker
8Z02	Honey
8Z03	Porcelain
8Z04	Celadon
8Z05	Spearmint
8Z06	Rye
8Z07	Frost
8Z08	Silver Birch

Ground Cloth®	
66" wide	
100% polyester	
4701	Vapor Grey
4721	Warm White *
4722	Fog *
4723	Straw *
4724	Red Orange *
4725	Wild Berry *
4726	Green Apple *
4727	Caribbean *
4728	Midnight *
4729	Cappuccino *

* Colors available on Exclave®
Video-friendly Tackable
Boards and Stowage Tackable
Backdrop

Kira 2	
54" wide	
100% recycled polyester	
5D11	Flaxen
5D12	Papyrus
5D13	Oasis
5D14	Incense
5D15	Ash
5D16	Falcon

Savannah	
66" wide	
76% recycled polyester	
24% polypropylene	
8L01	Pearl
8L02	Oyster
8L03	Wheat
8L04	Jute
8L05	Bamboo
8L06	Metal
8L07	Linen
8L08	Celadon
8L09	Moss
8L10	Frost
8L11	Shale
8L12	Pewter

Stitches	
54" wide	
54% polyester	
46% recycled polyester	
8U02	Rye
8U03	Khaki
8U04	Honey
8U05	Cattail
8U08	Cool Grey
8U09	Slate Blue
8U11	Evening Blue
8U12	Charcoal
8U13	Kiwi Green
8U16	Cocoa
8U17	Seed

Stitches	
For systems products only.	
54" wide	
54% polyester	
46% recycled polyester	
5Z01	White Ash

Price category 3 continued on next page

Proprietary Textile Colors — Workspaces

continued

Price Category 3

continued

Strands	
66" wide	
100% recycled polyester	
8W01	Pebble
8W02	Porcelain
8W03	Taupe
8W04	Honey
8W05	Khaki
8W06	Rye
8W07	Wicker
8W08	Tin
8W09	Cool Grey

Price Category 4

Glisten	
66" wide	
84% polyester	
16% recycled polyester	
2X02	Rye
2X05	Iceberg
2X07	Celadon
2X09	Pewter
2X10	Ash

Quilty	
56" wide	
100% antimony-free polyester	
GreenShield	
6S03	Khaki
6S04	Straw
6S07	Brick
6S10	Mink
6S11	Green Apple
6S13	Indigo
6S14	Zinc
6S15	Slate
6S16	Beachwood
6S17	Paprika
6S18	Plum
6S19	Juniper
6S20	Grey Black

Sironetta	
66" wide	
100% recycled polyester	
6301	Acapella
6302	Sonata
6303	Interlude
6304	Legato
6308	Harmony
6309	Ensemble

Price Category 5-6

No fabrics available at this time.



Proprietary Textiles Application Chart — Seating

• Available

[A] Assigned lead-time textile.

See following page for exception notes.

[N] Non-woven textile.

	Aeron® Chairs	Mirra® 2 Chairs/Stools	Celle® Chairs	Embody® Chairs	Sayl® Work Chairs/Stools	Sayl Side Chairs	Setu® Chairs/Stools	Setu Lounge Chair/Ottoman	Verus™ Work Chairs/Stools Back	Verus Work Chairs/Stools Seat	Verus Side Chairs Back	Verus Side Chairs Seat	Ergon 3® Chairs	Equa 2 Fully Upholstered Chairs/Stools	Equa 2 Split-Pad Upholstered Chairs/Stools	Aside® Chairs	Caper® Chairs/Stools	Keyn Chair Group Back	Keyn Chair Group Seat	Locale® Bench Cushion	Public® Office Landscape Back	Public Office Landscape Seat	Swoop™ Lounge Seating - Fully Upholstered	Swoop Lounge Seating - Plywood	Cushion Tops	Workspaces	
Price Category 1																											
COM Customer's Own Material [A]			14		1	1							1	1	1	1			1	1		1	1	1	1	1	1
231__ 8Z Pellicle®	•																										
1A7__ AireWeave 2		•																									
3P__ ColorGuard [N]			15		•	22	•	•	•	•	•	•	2		3	8		•	•	•			•	•	•	•	
8T__ Crossing			•				•	•					•	•	•	•				•			•	•	•	•	
6V__ Flexnet™																	•										
95__ Gem			14				•	•					•	•	•	•				•			•	•	•	•	
65__ Interweave									•		•																
4W__ Lyris 2™							•	•			•																
1MN__ Monologue			14		24	22	•	•	•	•	•	•						•	•	•		•	•	•	•	•	
3D__ Pellicle® Classic (3V__)																											
1WS__ Whisper			14		24	•	•	•	•	•	•	•	•	•	•	•		•	•	•		•	•	•	•	•	
Price Category 2																											
92__ Crepe			•		•	•	•	•	•	•	•	•	•	•	•	•		•	•	•			•	•	•	•	
1LM__ Loom			14		•	•			•	•	•	•		•				•	•	•		•	•	•	•	•	
1MV__ Marvel						21	22												•								
1HA__ Medley			14		•	•	22		•	•	•	•	•	•	•	•		•	•	•	•	•	•	•	•	•	
3A__ Moiré			14		•	•	•	•	•	•	•	•	•	•	•	•		•	•	•		•	•	•	•	•	
30__ Rhythm			•	23	•	•			•	•	•	•		•	•	•		•	•	•		•	•	•	•	•	
1RV__ Rivet			14						•	•	•	•						•	•	•		•	•	•	•	•	
8R__ Twist			•		•	•	•	•	•	•	•	•	•	•	•	•		•	•	•		•	•	•	•	•	
Price Category 3																											
70__ Bento					•	•	•	•	•	•	•	•	2	•	•	8		•								•	
8M__ Latitude™			23		•	•									3							•	•				
8U__ Stitches			•		•	•	•	•	•	•	•	•	•	•	•	•		•	•			•	•	•	•	•	
Price Category 4																											
7Y__ Bingo [N]							•	•	•	•	•	•	2		3	8		•	•	•						•	
213__ Mercer			14		•	21	22		•	•	•	•						•	•			•	•	•	•	•	
1A9__ Network																				•							
6J__ Plateau													•	•	•	•										•	
6S__ Quilty			14		•	•			•	•	•	•						•	•	•		•	•	•	•	•	
8Y__ Spools			14		21	•			•	•	•	•	•	•	•	•		•	•	•		•	•	•	•	•	
22P__ Strata					•	•	•		•	•	•	•	•	•	•	•		•	•	•	•	•	•	•	•	•	
Price Category 5																											
No fabrics available at this time																											
Price Category 6																											
35__ Balance				•			•																				
Price Category 7																											
COL Customer's Own Leather [A]	1		14										1	1	1	8										1	
Price Category 8																											
No fabrics available at this time																											
Price Category 9																											
21__ Leather	23		14											•	•	8								•	•		

Proprietary Textiles Application Chart — Seating

continued

• Available

[A] Assigned lead-time textile.

See below for exception notes.

[N] Non-woven textile.

Fire-Retardant Chairs/Fabrics

	Mirra® 2 Chairs/Stools with Butterfly Back™	Celle® Chairs	Embody® Chairs	Sayl® Work Chairs/Stools	Sayl Side Chairs	Setu® Chairs/Stools	Setu Lounge Chair/Ottoman	Ergon 3® Chairs	Equa 2® Fully Upholstered Chairs/Stools	Equa 2 Split-Pad Upholstered Chairs/Stools	Aside® Chairs	Caper® Chairs/Stools	Swoop™ Lounge Seating - Fully Upholstered
Price Category 1													
COM Customer's Own Material [A]							1	1	1	1			
1A7__ AireWeave™ 2	•												
3P__ ColorGuard [N]		15	24	22			2		3	8			•
8T__ Crossing		14				•	•	•	•	•			•
6V__ Flexnet™												•	
95__ Gem		14				•	•	•	•	•			•
4W__ Lyris 2™					18	•							
Price Category 2													
92__ Crepe		14	•	•				•	•	•			•
3A__ Moiré		14	•	•	•	•	•	•	•	•			
30__ Rhythm		14	24	•						8			•
8R__ Twist		14	•	•	•	•	•		•	8			•
Price Category 3													
70__ Bento				•	•	•	•	2			8		•
8M__ Latitude™		•	•	•									
8U__ Stitches		14	•	•	•	•	•	•	•	•			•
Price Category 4													
6J__ Plateau											•		
6S__ QUILTY		14	•	•									•
Price Category 5													
No fabrics available at this time													
Price Category 6													
35__ BALANCE			17										
Price Category 9													
21__ Leather		14									8		

All foam and Proprietary Textiles on HermanMiller seating comply with California TB 117-2013.

Application Note: Herman Miller cannot guarantee material/pattern alignment in adjacent products. For example, a fabric's pattern may not align from one pedestal cushion top to the next, or from one chair to the next.

1 Refer to price book appendices and Kiosk for COM/COL information.

2 Available on all Ergon 3 chairs except for fabric back (FB) option.

3 Available on A-and B-size Equa 2 split-pad upholstered chairs.

8 Only available on non-upholstered outer back (PB) option.

14 Available on Celle UC (upholstered seat) and HC (upholstered seat with protective edge) chairs.

15 Available on Celle HC (upholstered seat with protective edge) Chairs.

17 Only available in 3512 Carbon and 3513 Black.

18 Only available in 4W26 Slate Grey, 4W30 Java and 4W31 Graphite.

21 Not available on Sayl upholstered back work chairs.

22 Not available on Sayl side chairs with upholstered backs.

23 Available in select colors. Refer to "Proprietary Textile Colors - Seating" for color offering.

24 Not available on Sayl upholstered High-Back Work Chairs.

Proprietary Textile Colors — Seating

Price Category 1

Customer's Own Material
See Order Information in
Appendices.
Assigned lead-time textile. A

8Z Pellicle®
For New Aeron® Chairs
56% elastomeric
44% polyester
23101 Mineral
23102 Carbon
23103 Graphite

AireWeave™ 2
For Mirra® 2 Chairs
67% elastomeric
33% antimony-free polyester
1A701 Alpine
1A702 Slate Grey
1A703 Graphite
1A704 Lime Green
1A705 Cappuccino
1A706 Urban Orange
1A707 Dark Turquoise
1A708 Twilight

ColorGuard
54" wide
100% vinyl
3P01 Grey
3P02 Navy
3P03 Spruce A
3P08 Blueberry A
3P12 Black Plum A
3P14 Black
3P19 Slate
3P31 Horizon Blue A
3P33 Pumice
3P54 Candy Apple A
3P72 Allspice A
3P96 Manzanita A
3P97 Fudge A
3PB2 Sea Grass A
3PB5 Vizcaya Palm A
3PB9 Neptune A
3PC7 Bucksuede A
3PD4 Otter A

A Assigned lead-time color.

Crossing
54" wide
86% antimony-free polyester
14% polyester
8T03 Wicker
8T04 Porcelain
8T05 Warm Grey
8T06 Sepia
8T07 Pumpkin
8T08 Copper
8T09 Cranberry
8T10 Tomato
8T11 Mulberry
8T12 Plum
8T13 Green Apple
8T14 Loden
8T15 Spruce
8T16 Periwinkle
8T17 Cerulean
8T18 Indigo
8T19 Shale
8T20 Brownstone
8T21 Bark
8T22 Tin
8T23 Graphite
8T24 Black

Flexnet™
For Caper® Chairs
69% elastomeric
31% polyester
6V01 Black
6V02 Silver Grey

Gem
54" wide
100% antimony-free polyester
9501 Sesame
9502 Tangerine
9503 Red
9504 Red Violet
9505 Mulberry
9506 Java
9507 Twilight
9508 Bayou
9509 Iris
9510 Berry Blue
9511 Aqua Green
9512 Green Apple
9513 Spruce
9514 Black
9515 Slate Grey
9516 Fog

Interweave
For Verus™ Chairs
71% elastomeric
29% polyester
6504 Pewter
6505 Charcoal
6506 Black

Lyris 2™
For Setu® Chairs
74% elastomeric
26% polyester
4W21 Alpine
4W22 Mango
4W23 Chartreuse
4W25 Berry Blue
4W26 Slate Grey
4W28 Chino
4W29 Rattan
4W30 Java
4W31 Graphite

Proprietary Textile Colors — Seating

continued

Price Category 1

continued

Appendix: Proprietary Textile Colors — Seating

Monologue

54" wide	
56% recycled polyester	
44% polyester	
1MN01	Linen
1MN02	Alabaster
1MN03	Truffle
1MN04	Folkstone
1MN05	Silver Pine
1MN06	Slate
1MN07	Seed
1MN08	Yellow Oxide
1MN09	Persimmon
1MN10	Tundra
1MN11	Meadow
1MN12	Blue Sky
1MN13	Blue Spruce
1MN14	Deep Sea

Whisper

54" wide	
73% recycled polyester	
27% polyester	
1WS01	Sand Dollar
1WS02	Pebble
1WS03	Silver Birch
1WS04	Iceberg
1WS05	Silver Pine
1WS06	Carbon
1WS07	Cumin
1WS08	Adobe
1WS09	Strawberry
1WS10	Blush
1WS11	Eggplant
1WS12	Willow
1WS13	Sea Grass
1WS14	Pool
1WS15	Blueberry

Crepe

54" wide	
100% recycled polyester	
9201	Licorice
9203	Smoke
9207	Cherry
9209	Claret
9212	Raisin
9218	Aquamarine
9223	Cadet
9241	Beachglass
9243	Midnight
9244	Artichoke
9248	Warm White
9249	Stone
9250	Earth
9251	Fog
9252	Slate Grey
9253	Yellow Dark
9254	Coral
9255	Blush Grey
9256	Wild Berry
9257	Clover
9258	Caribbean
9259	Cerulean
9260	Brownstone
9261	Shale
9262	Graphite
9263	Tomato
9264	Green Apple

Loom

54" wide	
100% polyester	
1LM01	Linen
1LM02	Brown Sugar and Spice
1LM03	Brick and Mortar
1LM04	Salt and Pepper
1LM05	Black
1LM06	Lemongrass
1LM07	Poppy
1LM08	Wild Berry
1LM09	Loden
1LM10	Jade
1LM11	Deep Sea

Price Category 2

Medley

54" wide	
100% polyester	
1HA01	Stone
1HA02	Trail
1HA03	Charcoal
1HA04	Cinder
1HA05	Citrus
1HA06	Papaya
1HA07	Chutney
1HA08	Tundra
1HA09	Feather Grey
1HA10	Chartreuse
1HA11	Loden
1HA12	Peacock
1HA13	Bayou
1HA14	Blue Grotto
1HA15	Blueberry
1HA22	Khaki
1HA23	Pewter
1HA24	Yellow Oxide
1HA25	Vintage Rose
1HA26	Raspberry
1HA27	Acai Berry

Moiré

54" wide	
100% recycled polyester	
3A01	Concrete
3A02	Biscotti
3A03	Rattan
3A04	Chambray
3A05	Fern
3A08	Violet
3A09	Zin
3A10	Curry
3A11	Spice
3A12	Cork

Rhythm

54" wide	
100% polyester	
3001	Kiwi Green *
3002	Green Apple
3003	Peacock
3004	Bayou *
3005	Berry Blue
3006	Iris
3007	Twilight
3008	Pumpkin *
3009	Poppy *
3010	Molasses
3011	Mulberry
3012	Khaki *
3013	Mink
3014	Black
3015	Charcoal

* Colors not available on Embody Chair

Rivet

54" wide	
100% recycled polyester	
1RV01	Twig
1RV02	Deep Clay
1RV03	Woodrose
1RV04	Otter
1RV05	Hemlock
1RV06	Olive
1RV07	Lagoon
1RV08	Deep Sea
1RV09	Charcoal
1RV10	Grey Brindle

Price category 2 continued on next page

Proprietary Textile Colors — Seating

continued

Price Category 2

continued

Twist	
54" wide	
80% antimony-free polyester	
13% recycled polyester	
7% polyester	
8R05	Wicker
8R10	Poppy
8R14	Tin
8R15	Shale
8R16	Graphite
8R17	Birch
8R18	Sepia
8R22	Blueberry
8R23	Green Apple
8R26	Gunmetal
8R27	Cinder
8R28	Citrus
8R29	Pekoe
8R30	Tangerine
8R31	Red Plum
8R32	Wisteria
8R33	Forest
8R34	Jade Dark
8R35	Waterfall
8R36	Midnight Blue
8R37	Carbon Dark

Price Category 3

Bento	
54" wide	
100% antimony-free polyester	
7001	Frost
7002	Linen
7003	Khaki
7004	Truffle
7005	Grey Black
7006	Pumpkin
7007	Cranberry
7008	Everglade
7009	Cobalt

Latitude™	
61" wide	
100% polyester	
8M01	Graphite
8M02	Shadow
8M10	Alpine
8M17	Black
8M21	Slate Grey
8M22	Lime Green
8M23	French Press
8M24	Urban Orange
8M25	Dark Turquoise
8M26	Twilight

Stitches	
54" wide	
54% polyester	
46% recycled polyester	
8U02	Rye
8U03	Khaki
8U04	Honey
8U05	Cattail
8U08	Cool Grey
8U09	Slate Blue
8U11	Evening Blue
8U12	Charcoal
8U13	Kiwi Green
8U16	Cocoa
8U17	Seed

Price Category 4

Bingo	
54" wide	
100% PVC-free polyurethane	
Resilience® finish	
7Y01	Oyster
7Y02	Natural
7Y03	Cashew
7Y05	Rattan
7Y06	Root
7Y07	Woodland
7Y10	Allspice
7Y11	Canyon
7Y17	Seed
7Y18	Mushroom
7Y19	Blue Grey
7Y21	Black
7Y22	Mint
7Y23	Seaport
7Y24	Evening Blue
7Y26	Kiwi Green
7Y27	Celadon
7Y29	Pesto

Mercer	
54" wide	
50% solution dyed recycled nylon	
50% solution dyed nylon	
BLOCKaide	
21301	Stone
21303	Cayenne
21305	Pesto
21306	Teal Blue
21307	Ultramarine
21310	Charcoal

Network	
For Public Office Landscape®	
sectional back/social chair.	
knit to size	
100% polyester	
1A901	Warm White
1A902	Fog
1A903	Red
1A904	Wildberry
1A905	Green Apple
1A906	Twilight
1A907	Graphite

Plateau	
knit to size	
100% polyester	
6J01	Feather Grey
6J02	Trail
6J06	Twig
6J08	Sagebrush
6J09	Winter Berry
6J10	Thunder
6J11	Blueberry
6J12	Rosemary
6J14	Black

Quilty	
56" wide	
100% antimony-free polyester	
GreenShield	
6S03	Khaki
6S04	Straw
6S07	Brick
6S10	Mink
6S11	Green Apple
6S13	Indigo
6S14	Zinc
6S15	Slate
6S16	Beachwood
6S17	Paprika
6S18	Plum
6S19	Juniper
6S20	Grey Black

Price category 4 continued on next page

Proprietary Textile Colors — Seating

continued

Price Category 4

continued

Spools

54" wide
 51% recycled polyester
 49% polyester
 Crypton® Green

8Y03	Trail
8Y05	Copper
8Y08	Bluegrass
8Y09	Lagoon
8Y11	Beachglass
8Y12	Marsh
8Y13	Bud

Strata

54" wide
 50% solution dyed recycled nylon
 50% solution dyed nylon
 BLOCKaide

22P04	Pesto
22P05	Peacock
22P06	Blue Jay
22P07	Blueberry
22P09	Mango
22P10	Paprika
22P12	Wheat
22P13	Brownstone
22P14	Bayou

Price Category 5

No fabrics available at this time.

Price Category 6

Balance

100% polyester	
3506	Green Apple
3507	Blue Moon
3509	Berry Blue
3510	Iris
3512	Carbon
3513	Black

Price Category 7

Customer's Own Leather

See Order Information in Appendices. Assigned lead-time textile. [A](#)

Proprietary Textile Colors — Seating

continued

Price Category 8

No fabrics available at this time.

Price Category 9

Leather

approx. 50 sq. ft. per hide
100% leather

2101	Ivory
2109	Black *
2110	Smoke
2111	Graphite
2112	Khaki
2113	Rattan
2114	Truffle
2115	Alpine
2116	Haze
2117	Sable Grey
2118	Dark Mineral **
2119	Dark Carbon ***
2120	Cranberry
2121	Deep Sea

* Armpad color available on Aeron® Chair, Graphite.

** Armpad color available on Aeron Chair, Mineral.

*** Armpad color available on Aeron Chair, Carbon.

For more information about our products and services or to see a list of dealers, please visit us at HermanMiller.com or call (800) 851 1196.

© 2018 Herman Miller, Inc., Zeeland, Michigan

® **HermanMiller**, ●, Action Office, Aeron, Aside, Avive, Canvas Office Landscape, Caper, Celle, Co/Struc, Eames, Embody, Equa 2, Ergon 3, Ethospace, Exclave, Fine-Tune, FlexFront, Formcoat, Ground Cloth, Herman Miller Healthcare, Layout Studio, Maharam, Meridian, Mirra, Passage, Pellicle, Perspectives, PostureFit, Resolve, Sayl, Setu, Thrive, Tu, Y-Tower, and Z-Axis are among the registered trademarks of Herman Miller, Inc., and its owned subsidiaries.

™ AireWeave, Bubbletack, Cellular Suspension, Compass, Connect, DOT, Durawrap, Everywhere, Flex-Edge, Hopsak 2, Intent, Iota, Keyless Entry, Latitude, Lyris 2, Motia, Multiscrim, Nelson, Renew, Stackable, Swoop, TriFlex, Twist, and Verus are among the trademarks of Herman Miller, Inc., and its owned subsidiaries.

®Chemsurf® is a registered trademark of Wilsonart International.

Corian® is a registered trademark of E.I. du Pont de Nemours and Company Corporation.

FLEXNET™ is a trademark of Milliken & Company.

Floor Saver Glide® is a registered trademark of Carpin Manufacturing, Inc.

Geiger® is a registered trademark of Geiger International.

Microsoft® and Natural® Keyboard are registered trademarks of Microsoft Corporation.

Place Textiles® is a registered trademark of Place Textiles.