



GSA prices effective April 2, 2018  
(based on February 6, 2017, commercial price list)  
Published April 2018

## Conference Room and Multipurpose Tables Everywhere™ Tables

### **General Services Administration Federal Supply Service Authorized Federal Supply Schedule Price List**

Online access to contract ordering information, terms and conditions, up-to-date pricing, and the option to create an electronic delivery order is available through GSA Advantage!, a menu-driven database system. The Internet address for GSA Advantage! is [www.gsaadvantage.gov](http://www.gsaadvantage.gov).

Office Furniture  
FSC Group 71, Part 1  
Contract Number: GS-03F-036DA  
Contract Period: December 21, 2015—December 20, 2020

Herman Miller, Inc.  
855 East Main Avenue  
Zeeland, Michigan 49464  
(616) 654 3000 Phone  
(616) 654 8278 Fax  
[www.HermanMiller.com/government](http://www.HermanMiller.com/government)

Business Size: Large



# Contract Information

## 1a. Special Item Numbers (SIN)

SIN 71-1  
Packaged Offices

SIN 711-1  
Furniture Systems

SIN 711-2  
Computer Furniture

SIN 711-3  
Filing and Storage Cabinets

SIN 711-11  
Tables and Accessories

SIN 711-16  
Upholstered Seating

SIN 711-18  
Multi-Purpose Seating

SIN 711-91  
Project Management

Services under this SIN may be used only in conjunction with the purchase of new furniture. Please contact your local Herman Miller representative to discuss the available labor categories (listed below). The hourly rates listed are "Not To Exceed" or "NTE" values.

Furniture Project Manager: \$64.75 per hour  
Furniture Project Coordinator: \$49.00 per hour  
Build-Out Project Manager: \$80.00 per hour

SIN 711-93  
Reconfiguration and Relocation Services

Reconfiguration and Relocation Services will be provided by Herman Miller, Inc., or its participating dealer based on a fee not to exceed \$55 per hour, which applies to services totaling \$150,000 (per SIN) and below only. Services above \$150,000 shall be negotiated on a case-by-case basis. This SIN may only be used with the purchase of new product under SIN 711-1.

See \* Additional Notes for Installation & Reconfiguration and Relocation Services.

SIN 711-94  
Design/Layout

Design service will be provided by Herman Miller, Inc., or its participating dealer based on a fee not to exceed \$65 per hour.

SIN 711-95

Installation Services

Installation Services will be provided by Herman Miller, Inc., or its participating dealer based on a fee not to exceed \$55 per hour (\$82.50 per hour for after-hours Installation), which applies to services totaling \$150,000 (per SIN) and below only. Services above \$150,000 shall be negotiated on a case-by-case basis.

See \* Additional Notes for Installation & Reconfiguration and Relocation Services.

\* Additional Notes for Installation & Reconfiguration and Relocation Services:

FOB Destination (Drop Ship): Price includes product delivery to the site, brought to the tailgate of the truck. The purchaser is responsible for unloading.

Prices effective up to the maximum order by SIN only. Above the MO, pricing shall be negotiated on a case-by-case basis between the client and local dealer.

Standard Services are Subject to the Following Conditions:

Installation will be performed during normal weekday working hours.

Adequate facilities for delivery, unloading, moving and staging/ storing the product during the installation process shall be provided.

Service work will not be hindered by other trades.

Electric, heat, and adequate elevator service will be furnished without charge.

The immediate installation area shall be complete and free of debris including the carpet/flooring before installation commences.

Any work requiring a licensed electrician is the responsibility of the buyer.

Additional Charges May Apply For:

Major Metro Markets and any non-ground floor installation.

Major Metro Markets include large population centers and urban environments.

Installation in a clinical/medical environment.

Special restrictions or limits established by local laws, ordinances or the directions of the buyer, including but not limited to restrictions on transportations of materials, street access to the job site and/or dock facilities.

Installations outside of a 50 mile radius of the servicing dealer.

Local Prevailing Wage and/or Union Labor Rates.

Any additional charges shall be quoted by the dealer and approved by the buyer prior to performance of the work.

SIN 711-96

Leasing

Contact Herman Miller participating government dealer for current leasing information.

SIN 711-99

New Product Introductions

# Contract Information

continued

## 1b. Lowest Priced Model

|             |         |      |
|-------------|---------|------|
| SIN 711-1:  | G9999.B | \$7  |
| SIN 711-2:  | 6-5-D   | \$35 |
| SIN 711-3:  | 9M10018 | \$14 |
| SIN 711-11: | DT9A.   | \$36 |
| SIN 711-16: | OA401   | \$41 |
| SIN 711-18: | AS90598 | \$46 |
| SIN 711-99: | R1366   | \$27 |

## 1c. Not applicable

## 2. Maximum Order

SIN 711-1, SIN 711-2  
\$500,000 net product value

SIN 711-3, SIN 711-11  
\$300,000 net product value

SIN 711-16, SIN 711-18  
\$200,000 net product value

SIN 711-93  
\$150,000

SIN 711-94  
\$150,000

SIN 711-95  
\$150,000

SIN 711-96  
\$500,000 net product value

SIN 711-99  
\$50,000 net product value

## 3. Minimum Order

\$100 net

## 4. Geographic Coverage

Continental U.S.

Orders for Alaska, Hawaii, and Puerto Rico will be shipped F.O.B. inland carrier point of exportation.

## 5. Point of Production

Zeeland, Ottawa County, Michigan  
Spring Lake, Ottawa County, Michigan

## 6. Pricing

Prices shown are list. Discounts include Industrial Funding Fee.

SIN 711-1

Product: Selected Action Office 1, Action Office 2, C-Style Overhead Storage, Ethospace System, Quadrant Pedestals, Supplemental Products, Tu Pedestals and Pedastools, and approved Herman Miller Options Products.

| Standard Lead Time | Single Order Net Purchase | Discount From list |
|--------------------|---------------------------|--------------------|
|                    | \$100 - 250,000           | 73.8%              |
|                    | \$250,001 - 500,000       | 76.8%              |

SIN 711-1

Product: Selected Renew™ Tables, Renew Link and approved Herman Miller Options Products

| Standard Lead Time | Single Order Net Purchase | Discount From List |
|--------------------|---------------------------|--------------------|
|                    | \$100 - 500,000           | 72.8%              |

SIN 711-1

Product: Selected Motia™ Tables, and approved Herman Miller Options Products

| Standard Lead Time | Single Order Net Purchase | Discount From List |
|--------------------|---------------------------|--------------------|
|                    | \$100 - 500,000           | 73.8%              |

SIN 711-1

Product: Tu Wood Pedestals and approved Herman Miller Options Products

| Standard Lead Time | Single Order Net Purchase | Discount From List |
|--------------------|---------------------------|--------------------|
|                    | \$100 - 300,000           | 74.3%              |

SIN 711-1

Product: Selected Canvas Office Landscape and approved Herman Miller Options Products

| Standard Lead Time | Single Order Net Purchase | Discount From List |
|--------------------|---------------------------|--------------------|
|                    | \$100 - 500,000           | 74.8%              |

SIN 711-1

Product: Selected Layout Studio® and approved Herman Miller Options Products

| Standard Lead Time | Single Order Net Purchase | Discount From List |
|--------------------|---------------------------|--------------------|
|                    | \$100 - 500,000           | 60.7%              |

SIN 711-1

Product: Selected Meridian Pedestals, Meridian Pedastools, and approved Herman Miller Options Products

| Standard Lead Time | Single Order Net Purchase | Discount From List |
|--------------------|---------------------------|--------------------|
|                    | \$100 - 500,000           | 64.2%              |

# Contract Information

continued

SIN 711-1

Product: Selected Thrive Portfolio and approved Herman Miller Options Products

| Standard Lead Time | Single Order Net Purchase | Discount From List |
|--------------------|---------------------------|--------------------|
|                    | \$100 - 250,000           | 62%                |
|                    | \$250,001 - 500,000       | 66.4%              |

SIN 711-2

Product: Passage Desking System and approved Herman Miller Options Products

| Standard Lead Time | Single Order Net Purchase | Discount From List |
|--------------------|---------------------------|--------------------|
|                    | \$100 - 500,000           | 56.7%              |

SIN 711-2

Product: 5000 Series Furniture and approved Herman Miller Options Products

| Standard Lead Time | Single Order Net Purchase | Discount From List |
|--------------------|---------------------------|--------------------|
|                    | \$100 - 500,000           | 58.7%              |

SIN 711-3

Product: Meridian Laterals, Verticals, Towers, and Storage products and approved Herman Miller Options Products

| Standard Lead Time | Single Order Net Purchase | Discount From List Laterals | Verticals | Towers & Storage |
|--------------------|---------------------------|-----------------------------|-----------|------------------|
|                    | \$100 - 300,000           | 67.3%                       | 66.3%     | 62.7%            |

SIN 711-3

Product: Tu Lateral Files, Tu Storage, Tu Towers, Tu Wood Cases, Tu Wood Cubbies, Tu Wood Credenzas, Tu Wood Towers, and approved Herman Miller Options Products

| Standard Lead Time | Single Order Net Purchase | Discount From List |
|--------------------|---------------------------|--------------------|
|                    | \$100 - 300,000           | 74.3%              |

SIN 711-11

Product: Selected Tables and Accessories and approved Herman Miller Options Products

| Standard Lead Time          | Single Order Net Purchase | Discount From List |
|-----------------------------|---------------------------|--------------------|
| Avive® Tables               | \$100 - 250,000           | 72.8%              |
|                             | \$250,001 - 500,000       | 74.8%              |
| Herman Miller Eames® Tables | \$100 - 250,000           | 73.6%              |
|                             | \$250,001 - 300,000       | 77.6%              |
| Everywhere™ Tables          | \$100 - 300,000           | 72.8%              |

SIN 711-16

Product: Swoop upholstered seating products and approved Herman Miller Options Products

| Standard Lead Time | Single Order Net Purchase | Discount From List |
|--------------------|---------------------------|--------------------|
| Swoop™             | \$100 - 200,000           | 60.7%              |

SIN 711-18

Product: Selected Seating and approved Herman Miller Options Products

| Standard Lead Time       | Single Order Net Purchase | Discount From List |
|--------------------------|---------------------------|--------------------|
| Aeron® (Classic and New) | \$100 - 200,000           | 64.5%              |
| Aside®                   | \$100 - 200,000           | 64.2%              |
| Caper®                   | \$100 - 200,000           | 61.5%              |
| Celle®                   | \$100 - 200,000           | 59.7%              |
| Embody®                  | \$100 - 200,000           | 59.7%              |
| Equa 2®                  | \$100 - 200,000           | 65.8%              |
| Ergon 3®                 | \$100 - 200,000           | 68.8%              |
| Keyn                     | \$100 - 200,000           | 57.7%              |
| Mirra® 2                 | \$100 - 200,000           | 61.7%              |
| Setu®                    | \$100 - 200,000           | 59.7%              |
| Sayl®                    | \$100 - 200,000           | 62.2%              |
| Verus™                   | \$100 - 200,000           | 63.7%              |

SIN 711-99

Product: Selected Exclave™, Locale®, Public Office Landscape®, Resolve® System, and approved Herman Miller Options Products

| Standard Lead Time      | Single Order Net Purchase | Discount From List |
|-------------------------|---------------------------|--------------------|
| Exclave                 | \$100 - 50,000            | 61.7%              |
| Locale                  | \$100 - 50,000            | 63.7%              |
| Public Office Landscape | \$100 - 50,000            | 61.7%              |
| Resolve System          | \$100 - 50,000            | 69.8%              |
| Intent Solution         | \$100 - 50,000            | 58.7%              |

## 7. Quantity Discounts

Reference item #6.

## 8. Payment Term

Net 30 days

## 9. Government Commercial Credit Card

- Government commercial credit cards are accepted below the micropurchase threshold.
- Government commercial credit cards are accepted above the micropurchase threshold.

## 10. Foreign Items

None

## 11. Time of Delivery

- 90 day ARO
- Expedited delivery: Items listed in the 10-Day section of the catalogs are available for expedited delivery.
- Overnight/2-day delivery: Select items may be available for overnight or 2-day delivery. Contact Herman Miller or a participating dealer for availability and rates.
- Urgent requirements: Agencies may contact contractor or participating dealer to request faster delivery.

# Contract Information

continued

## 12. F.O.B.

F.O.B. destination except Alaska, Hawaii, and Puerto Rico, which will be shipped F.O.B. inland carrier point of exportation.

## 13. Ordering Address

- a. Herman Miller, Inc.,  
Government Customer Care 0161  
855 East Main Avenue  
Zeeland MI 49464.
- b. For supplies and services, the ordering procedures information on Blanket Purchase Agreements (BPA's) and a sample BPA can be found at the GSA/FSS Schedule homepage ([www.fss.gsa.gov/schedules](http://www.fss.gsa.gov/schedules)).

## 14. Payment Address.

Herman Miller, Inc.  
22764 Network Place  
Chicago, IL 60673-1227

## 15. Warranty

Herman Miller, Inc., commercial warranty applies.

## 16. Export Packing Charge

Prices supplied on request.

## 17. Terms and Conditions of Government Purchase Card Acceptance

(any thresholds above the micropurchase level)  
None.

## 18. Rental Maintenance and Repair Terms

Not applicable

## 19. Terms and Conditions of Installation

Installation Services will be provided by Herman Miller, Inc., or its participating dealer based on a fee not to exceed \$55 per hour (\$82.50 per hour for after-hours Installation), which applies to services totaling \$150,000 (per SIN) and below only. Services above \$150,000 shall be negotiated on a case-by-case basis.

Additional Notes for Installation & Reconfiguration and Relocation Services:

FOB Destination (Drop Ship): Price includes product delivery to the site, brought to the tailgate of the truck. The purchaser is responsible for unloading.

Prices effective up to the maximum order by SIN only. Above the MO, pricing shall be negotiated on a case-by-case basis between the client and local dealer.

Standard Services are Subject to the Following Conditions:

Installation will be performed during normal weekday working hours.

Adequate facilities for delivery, unloading, moving and staging/storing the product during the installation process shall be provided.

Service work will not be hindered by other trades.

Electric, heat, and adequate elevator service will be furnished without charge.

The immediate installation area shall be complete and free of debris including the carpet/flooring before installation commences.

Any work requiring a licensed electrician is the responsibility of the buyer.

Additional Charges May Apply For:

Major Metro Markets and any non-ground floor installation.

Major Metro Markets include large population centers and urban environments.

Installation in a clinical/medical environment.

Special restrictions or limits established by local laws, ordinances or the directions of the buyer, including but not limited to restrictions on transportations of materials, street access to the job site and/or dock facilities.

Installations outside of a 50 mile radius of the servicing dealer.

Local Prevailing Wage and/or Union Labor Rates.

Any additional charges shall be quoted by the dealer and approved by the buyer prior to performance of the work.

## 20. Terms and Conditions of Repair Parts

Not applicable

## 21. Service and Distribution Points

For service and distribution points nearest you, call (800) 851 1196.

## 22. Participating Dealers

Access Herman Miller web site for current list of participating dealers: [www.HermanMiller.com/government](http://www.HermanMiller.com/government).

## 23. Preventive Maintenance

Not applicable

## 24a. Special Attributes.

2018

For the 11th consecutive year, Herman Miller received a perfect score on the Corporate Equality Index and we were designated as Best Place to Work for LGBT equality. This report evaluates U.S. companies in terms of diversity, particularly their LGBT-related policies and practices.

# Contract Information

*continued*

2017

Herman Miller was named the 2017 “Corporation of the Year” in the consumer products sector by the Michigan Minority Supplier Development Council (MMSDC).

Herman Miller has received a 2017 SEAL (Sustainability, Environmental Achievement and Leadership) Business Sustainability Award.

Herman Miller has earned the 4 Star Diversity Visionary Award. This award celebrates the diversity, equality, and inclusion work of Herman Miller. The award is presented at the annual Diversity Equity Inclusion Summit, held by the Grand Rapids Area Chamber of Commerce.

Herman Miller named one of the Best and Brightest in Wellness for the fifth year in a row.

Working Mother magazine has recognized Herman Miller as one of the 2017 Working Mother 100 Best Companies.

Herman Miller earned our tenth consecutive perfect score in Human Rights Campaign (HRC) Foundation’s 2017 Corporate Equality Index.

As one of the top-scoring companies in our industry for the thirteenth consecutive year, Herman Miller has qualified for inclusion in RobecoSAM’s 2017 Sustainability Yearbook and received the Bronze Class distinction for our excellent economic, environmental, and social sustainability performance.

Herman Miller has once again earned the WorldatWork Seal of Distinction, a unique standard of excellence in work-life effectiveness that shows we provide a distinct, mutually beneficial workplace experience.

2016

Herman Miller was recognized as the Business of the Year at the Annual Meeting of the West Michigan Environmental Action Council (WMEAC). This award goes to the business with the greatest depth and breadth of support, unwavering dedication to environmental action in West Michigan, and a strong corporate commitment to environmental advocacy.

The 101 Best and Brightest Sustainable Companies once again (fifth consecutive year) recognized Herman Miller as an organization in Michigan (and for the first time, in the nation) that exhibits leadership and innovation in its approach to sustainability.

Herman Miller has been recognized by the Michigan Minority Supplier Development Council (MMSDC), as a “Corporation of the Year”, and we also received a “2016 Excellence in Supplier Diversity Award” from the Great Lakes Women’s Business Council. Additionally, we are the only West Michigan company this year to receive an “Ambassadors Championing Excellence” Award from the MMSDC.

Plex Lounge Furniture from Herman Miller receives #MetropolisLikes award at NeoCon 2016.

Plex Lounge Furniture from Herman Miller receives Interior Design HiP Award for Workplace Seating/Lounge at NeoCon 2016.

Spot Stools from Herman Miller Collection receive Interior Design HiP Award for Hospitality Seating at NeoCon 2016.

Herman Miller has been named a 2020 Women on Boards Winning Company. Companies selected for this recognition are considered champions of board diversity as 20 percent or more of their board seats are occupied by women.

Herman Miller selected for inclusion in the 2016 RobecoSAM Sustainability Yearbook for twelfth consecutive year.

Herman Miller again earns the WorldatWork Work-Life 2016 Seal of Distinction. This award identifies organizations that focus on programs that promote work-life balance and overall well-being.

2015

Herman Miller earns ninth consecutive perfect score in Human Rights Campaign (HRC) Foundation’s 2016 Corporate Equality Index and we were designated as Best Place to Work for LGBT equality.

This is the fourth consecutive year that Herman Miller was named one of Michigan’s Best and Brightest Sustainable Companies.

Herman Miller has received the Best and Brightest in Wellness Award for the third year in a row. This program is an innovative initiative that recognizes and celebrates quality and excellence in health awareness.

Herman Miller received the Forest Stewardship Council (FSC) Leadership Award for longstanding commitment to manufacturing with wood sourced from responsibly managed forests, which reduces environmental impacts by protecting against deforestation and forest degradation.

Herman Miller accepted its second Excellence in Reusable Packaging Award from the Reusable Packaging Association.

Herman Miller has once again been recognized for its commitment to best-in-class economic, environmental, and societal sustainability, earning a spot on the prestigious Dow Jones Sustainability Index (DJSI) for the twelfth consecutive year. We are the only contract furniture company recognized globally for its corporate sustainability leadership.

Herman Miller selected for inclusion in the 2015 RobecoSAM Sustainability Yearbook; awarded Bronze Class distinction for excellent sustainability performance for the second consecutive year.

# Contract Information

*continued*

Herman Miller received a Michigan Business Pollution Prevention (MBP<sub>3</sub>) Certificate – a recognition given by the Michigan Department of Environmental Quality (MDEQ) to organizations committed to environmental stewardship, conservation, and sustainable operations. This basic partnership with the MDEQ, which we've maintained since 1998, makes us eligible for our Clean Corporate Citizen (CCC) status that began in 2004 and our Environmental Leader status, which we received for the first time this past year.

MedAssets named Herman Miller Healthcare as Platinum Suppliers. MedAssets, a large group purchasing organization, helps providers enhance operational and financial performance so they can sustainably serve the needs of their community.

Herman Miller honored with five of 20 spots for the Michigan Environmental Leaders Award by the Michigan Department of Environmental Quality for our outstanding, voluntary environmental stewardship.

Renew Sit-to-Stand tables recognized on Record Products 2014 list by Architectural Record.

Herman Miller was again awarded a perfect score in the 2015 Corporate Equality Index. This is the eighth consecutive year we received a perfect score.

2014

Herman Miller has received the Best and Brightest in Wellness Award for the second year in a row. This program is an innovative initiative that recognizes and celebrates quality and excellence in health awareness.

Herman Miller's Locale wins International Design Excellence Awards (IDEA) Gold in the Office & Productivity category.

Herman Miller achieves eleventh consecutive listing on Dow Jones Sustainability World Index, an international stock portfolio that evaluates the annual performance of the world's largest 2500 companies using economic, environmental, and social criteria, known as the "triple bottom line" of sustainability.

2013

Herman Miller achieves tenth consecutive listing on Dow Jones Sustainability World Index.

Herman Miller has received the Best and Brightest in Wellness Award. This program is an innovative initiative that recognizes and celebrates quality and excellence in health awareness.

Herman Miller Earns Perfect Score on the Corporate Equality Index. We are one of only 303 major U.S. businesses to receive a perfect score in 2013, an achievement we have now obtained seven years in a row.

Herman Miller is listed in Forbes Magazine inaugural "Platinum List" of America's 400 best managed, large companies.

For the second consecutive year, Herman Miller is honored as one of West Michigan's "101 Best and Brightest Sustainable Companies".

2012

Herman Miller accepted its first Excellence in Reusable Packaging Award from the Reusable Packaging Association.

Herman Miller is named "Corporation of the Year" in the commercial products sector by the Michigan Minority Supplier Development Council.

In July 2012 Herman Miller was inducted into the Made in the USA Hall of Fame. Herman Miller is one of only 20 companies across the nation to receive this distinction.

Herman Miller achieves ninth consecutive listing on Dow Jones Sustainability World Index.

Herman Miller is honored as one of West Michigan's 101 Best and Brightest Sustainable Companies.

The Sustainable Asset Management (SAM) group selected Herman Miller for inclusion in "The Sustainability Yearbook 2012" and has awarded Herman Miller both the "SAM Sector Leader" and "SAM Sector Mover" distinctions.

Herman Miller was named one of 16 Section Leaders on Climate Counts 2011-2012 Scorecard Report, making us the industry leader for Home and office Furnishings.

SGS International Certification Services, Inc., recognizes Herman Miller's manufacturing sites, Midwest Distribution Center, and Design Yard for initial certification to the OHSAS 18001 standard as well as re-certification to ISO 14001.

2011

Trust Across America, a company dedicated to unraveling the complexities of trustworthy business behavior, listed Herman Miller as one of their "Top Ten Most Trustworthy Companies in America 2011."

The U.S. Environmental Protection Agency (EPA) selected Herman Miller, as a WasteWise Gold Achievement—Climate Change winner.

Herman Miller achieves eighth consecutive listing on Dow Jones Sustainability World Index, an international stock portfolio that evaluates the annual performance of the world's largest 2500 companies using economic, environmental, and social criteria, known as the "triple bottom line" of sustainability.

The Michigan Minority Supplier Development Council (MMSDC) named Herman Miller as its "Corporation of the Year" in the commercial products sector. This was the fifth time Herman Miller has received this award since 2005.



# Contract Information

*continued*

Herman Miller accepted its third Neighborhood Environmental Partners (NEP) award from the Michigan Department of Natural Resources and Environment.

Herman Miller receives the Reader's Choice award from TreeHugger's Best of Green: Design and Architecture category for the SAYL chair.

Herman Miller earns Citibank's Global Environmental Vendor of the Year award.

The SAYL chair from Herman Miller was dubbed the "Product Design of the Year" from the 2010 International Design Awards (IDA) jury.

Herman Miller Healthcare's Compass system was awarded a 2011 Medical Design Excellence Award (MDEA) for its research-based design and ability to be used in a variety of healing spaces, while simultaneously improving the overall delivery of healthcare.

The Sustainable Asset Management (SAM) Group selected Herman Miller for inclusion in the "Sustainability Yearbook 2011" and awarded us both the "SAM Sector Leader" and "SAM Sector Mover" distinctions.

Herman Miller has received the top rating for a fourth consecutive year in the Human Rights Campaign (HRC) Foundation's eighth annual Corporate Equality Index. The "Best Places to Work for LGBT Equality" distinction is awarded to businesses that scored 100% on the HRC Foundation's 2011 Corporate Equality Index.

Herman Miller again tops contract furniture industry in FORTUNE's "Most Admired" Companies survey. For the 23rd time in 25 years.

2010

The NASDAQ OMX CRD Global Sustainability Index (QCRD) has included Herman Miller among their top 100 companies in the world.

Herman Miller achieves seventh consecutive listing on Dow Jones Sustainability World Index, an international stock portfolio that evaluates the annual performance of the world's largest 2500 companies using economic, environmental, and social criteria, known as the "triple bottom line" of sustainability. Herman Miller is one of approximately 300 companies worldwide and the only contract office furniture manufacturer, selected for this index.

Herman Miller has been recognized by Fast Company magazine as one of its 2010 Most Innovative Companies and among the more select Innovation All-Stars.

The U.S. Environmental Protection Agency's Office of Resource Conservation and Recovery has selected Herman Miller to receive the 2010 WasteWise Gold Achievement Award for Green Purchasing.

The Michigan Department of Natural Resources and Environment (MDNRE) has recognized Herman Miller's West Michigan manufacturing sites and Midwest Distribution Center as continuing Clean Corporate Citizens.

Herman Miller makes the U.S. Environmental Protection Agency's (EPA) list of the top fifty users of renewable electricity, of more than 1,200 organizations participating in the Green Power Partnership. This is the second consecutive time Herman Miller was recognized. Herman Miller was the only furniture manufacturer on the list.

Herman Miller accepted its second Neighborhood Environmental Partners (NEP) award from the Michigan Department of Natural Resources and Environment.

For the 22nd time in 24 years, Herman Miller was awarded the No. 1 industry ranking in a survey among the executives and board members of peer companies and independent industry analysts, as published in FORTUNE magazine's annual "Most Admired" companies feature.

The Michigan Department of Environmental Quality (MDEQ) recognizes Herman Miller's GreenHouse as one of Michigan's top environmental performers with a Clean Corporate Citizen (C3) longevity award. This recognizes that the GreenHouse has maintained its C3 designation for the past five years.

For the third year in a row, Herman Miller makes FORTUNE magazine's "100 Best Companies to Work For" list. Herman Miller is one of only three Michigan-based companies to make the list.

## **24b. Section 508 Compliance**

Not applicable

## **25. Data Universal Numbering System (DUNS): 00-601-2801**

## **26. Registered in System for Award Management (www.SAM.gov) Database**

## **27. Cancellation**

Prior to production, no cancellation charge will apply. After production, only actual cost incurred that the contractor can demonstrate if items are sold after 3 months.

## **28. Restocking Charges**

Agencies must notify the contractor for authorization prior to returning any items. The customer agency will be required to pay all packaging and return freight charges. A restocking fee of 50% for Systems Furniture and 35% for all other product lines will be charged for any returned items.

## **Herman Miller Miscellaneous Information:**

Federal ID Number: 38-0837640

Commercial and Government Entity Code (CAGE): 40636

Data Universal Numbering System (DUNS) 00-601-2801

Commercial Entity Code (CEC): 00702290J



|  |               |
|--|---------------|
| <b>Introduction</b>  | <b>page 2</b> |
| <b>Everywhere™ Tables</b>  | <b>3</b>      |
| Standard-Height Tables   | 5             |
| Standard-Height Table Legs and Bases   | 58            |
| Standing-Height Tables   | 61            |
| Occasional Tables  | 67            |
| Power and Data Support   | 73            |
| Accessories  | 89            |
| <b>Indices</b>   | <b>121</b>    |
| By Name  | 121           |
| By Number  | 123           |
| <b>Appendices</b>  |               |
| 20-Day or Less/Assigned Lead-Time Order Information  |               |
| Vary Easy Program  |               |
| <b>For the latest materials information, refer to the Materials pages on HermanMiller.com.</b> |               |

# Introduction

## A Note on the Organization of This Book

There are a few signals that will help you understand the organization of this book. Once you know them, you should be able to find your way around easily.

### Like a newspaper, this book is formatted with columns of text and illustrations that run vertically.

Information wraps from one column to the next and continues for as many pages as it needs to.

### Black bars are clues.

A black bar at the top of a page signals the start of information about a product.

This information is divided into two sections, each signaled by a black bar. Product Information includes a description, additional notes, and dimensional drawings. Specification Information, which always begins at the top of a column, includes a series of steps. Each step represents a decision you need to make in order to complete your product number. Steps must be followed sequentially. The number of pages needed to complete information on a product varies; some will be complete in one page; others may fill three or four pages. Just continue going through the steps until you run into the next product, signaled by the black bar at the top of the page.

Black tabs running along the outside edge of the page help you locate what section you are in or what section you want to go to. You can thumb forwards or backwards to find a section; tabs and text appear on both sides of the page.

The additional pages in the back of the book include the appendices and indices. They are signaled by a long black bar running along the outside edge of the page.

### The index is presented two ways.

The first index is in alphabetical order by product name. It can be helpful if you are new to the products and numbering scheme or if you are looking for a type of product, such as work chair or round table.

The second index is by product number. It lists, in alphanumeric order, the base product number, typically a five-digit number.

## General Information

This book is effective April 2, 2018, subject to change without notice. Products may be purchased from authorized Herman Miller dealers who will quote prices upon request. For more information about our products and services or to see a list of dealers, visit [www.HermanMiller.com](http://www.HermanMiller.com).

All prices are list prices. Additional services, such as planning services, design, storage, and installation, are not included and must be added to these prices when the additional services are requested.

Illustrations, specifications, and prices are based on the latest information at the time of publication. The right is reserved to make changes at any time without notice in prices, fabrics, finishes, materials, specifications, and models, and also to discontinue models and finishes.

Dimensions shown in the drawings are engineering drawing dimensions rounded up to the nearest  $\frac{1}{8}$ ". Product is shipped set up or knocked down. Products that include "Shipped knocked down" in the description require some assembly. If this statement does not appear in the description, the product is shipped assembled.

Service problems are normally handled by a Herman Miller authorized dealer. Where this cannot be accomplished on a local level, service problems should be referred to the Customer Care Representative for your region, Herman Miller, Inc., Zeeland, Michigan 49464.

### 20-Day or Less/Assigned Lead-Time Shipments

All products and options in this price book not designated by an Assigned Program icon  will ship in **20 business days or less** after being acknowledged by Herman Miller.

Products and options designated by an  are on the assigned lead-time program and may ship in 20 days, less than 20 days, or more than 20 days from order acknowledgement.

- Standard-Height Tables**
- Standard-Height Table Legs and Bases**
- Standing-Height Tables**
- Occasional Tables**
- Power and Data Support**
- Accessories**



# Rectangular Table

DT1AE.  
DT1AS.  
DT1AT.

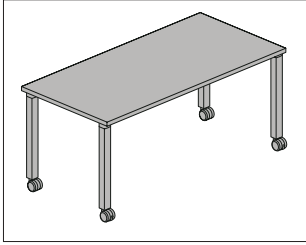

### Product Information

#### Description

This rectangular table comes in multiple edge styles and has a laminate top with thermoplastic edge, laminate top with a thermoplastic backed plywood edge, veneer top and edge, or painted top and edge. It has multiple leg options, and is available with casters or glides. The caster option has 2 locking and 2 non-locking casters. Glides have 1/2" leveling range. Shipped knocked down.

Height-adjustable legs have a 5" range in 1" increments.

#### Notes

18" depth available with square edge only.

C-leg and D-leg cannot be used with either the 18" deep or 36" deep tops.

When specifying grommets (253, 254, 255), cutouts will be located in the center of table.

Cutouts available for all Connect™ power and data accessories (see Thrive® Portfolio). Cutouts will be located in the center, laterally, and approximately 3" from the rear edge of surface.

Reinforcement channels are used under table tops 54" and wider. They will be located along the center line for 18" deep and 24" deep surfaces, and 19" from the front edge for 30" deep surfaces.

For additional details on available edge options see Appendices.

For additional size, edge, finish, and cable management options, see Vary Easy Program in Appendices.

Note: UL listed when used with Connect single circuit electrical product (Y137x.) with post leg (P), T-leg (T) and C-leg (C) options.

### Dimensions

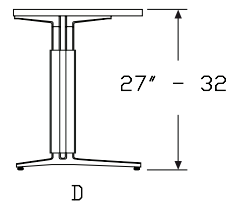
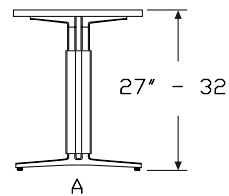
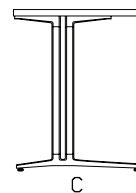
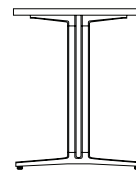
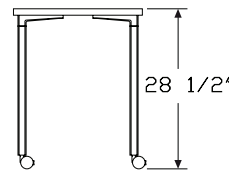
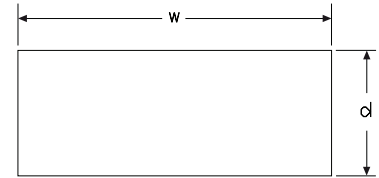

Rectangular Table *continued*

| Specification Information                    |              |
|--|--------------|
| Step 1.                                      |              |
| <b>DT1A</b>                                  |              |
| Step 2. Edge                                 |              |
| <b>S.</b>                                    | squared-edge |
| <b>T.</b>                                    | thin-edge    |
| <b>E.</b>                                    | eased-edge   |
| Step 3. Depth                                |              |
| <i>For squared-edge (S.)</i>                 |              |
| <b>18</b>                                    | 18" deep     |
| <b>24</b>                                    | 24" deep     |
| <b>30</b>                                    | 30" deep     |
| <b>36</b>                                    | 36" deep     |
| <i>For thin-edge (T.) or eased-edge (E.)</i> |              |
| <b>24</b>                                    | 24" deep     |
| <b>30</b>                                    | 30" deep     |
| <b>36</b>                                    | 36" deep     |
| Step 4. Width                                |              |
| <i>For 18" deep (18)</i>                     |              |
| <b>48</b>                                    | 48" wide     |
| <b>60</b>                                    | 60" wide     |
| <b>72</b>                                    | 72" wide     |
| <i>For 24" deep (24) or 30" deep (30)</i>    |              |
| <b>36</b>                                    | 36" wide     |
| <b>42</b>                                    | 42" wide     |
| <b>48</b>                                    | 48" wide     |
| <b>54</b>                                    | 54" wide     |
| <b>60</b>                                    | 60" wide     |
| <b>66</b>                                    | 66" wide     |
| <b>72</b>                                    | 72" wide     |
| <i>For 36" deep (36)</i>                     |              |
| <b>42</b>                                    | 42" wide     |
| <b>48</b>                                    | 48" wide     |
| <b>54</b>                                    | 54" wide     |
| <b>60</b>                                    | 60" wide     |
| <b>66</b>                                    | 66" wide     |
| <b>72</b>                                    | 72" wide     |

|   |                                 |
|---|---------------------------------|
| Step 5. Surface Material                  |                                 |
| <i>For squared-edge (S.)</i>              |                                 |
| <b>L</b>                                  | lamine top/thermoplastic edge   |
| <b>W</b>                                  | veneer top/veneer edge <b>A</b> |
| <b>P</b>                                  | painted Formcoat® top/edge      |
| <i>For thin-edge (T.)</i>                 |                                 |
| <b>W</b>                                  | veneer top/veneer edge <b>A</b> |
| <b>P</b>                                  | painted Formcoat® top/edge      |
| <i>For eased-edge (E.)</i>                |                                 |
| <b>P</b>                                  | painted Formcoat® top/edge      |
| Step 6. Leg Type                          |                                 |
| <i>For 18" deep (18) or 36" deep (36)</i> |                                 |
| <b>P</b>                                  | post leg                        |
| <b>T</b>                                  | T-leg                           |
| <b>A</b>                                  | T-leg with height adjustment    |
| <i>For 24" deep (24) or 30" deep (30)</i> |                                 |
| <b>P</b>                                  | post leg                        |
| <b>T</b>                                  | T-leg                           |
| <b>A</b>                                  | T-leg with height adjustment    |
| <b>C</b>                                  | C-leg                           |
| <b>D</b>                                  | C-leg with height adjustment    |

| Prices for Steps 1-6. |        |      |      |      |      |      |  |
|-----------------------|--------|------|------|------|------|------|--|
|                       | LP     | LT   | LA   | LC   | LD   | WP   |  |
| <b>DT1AS. 18 48</b>   | \$711  | 923  | 1155 | —    | —    | 867  |  |
| <b>60</b>             | \$782  | 1016 | 1269 | —    | —    | 958  |  |
| <b>72</b>             | \$844  | 1096 | 1371 | —    | —    | 1041 |  |
| <b>24 36</b>          | \$711  | 923  | 1155 | 923  | 1155 | 867  |  |
| <b>42</b>             | \$747  | 971  | 1212 | 971  | 1212 | 912  |  |
| <b>48</b>             | \$783  | 1018 | 1273 | 1018 | 1273 | 961  |  |
| <b>54</b>             | \$831  | 1080 | 1348 | 1080 | 1348 | 1021 |  |
| <b>60</b>             | \$880  | 1144 | 1428 | 1144 | 1428 | 1087 |  |
| <b>66</b>             | \$942  | 1225 | 1530 | 1225 | 1530 | 1166 |  |
| <b>72</b>             | \$1009 | 1310 | 1636 | 1310 | 1636 | 1251 |  |
| <b>30 36</b>          | \$739  | 959  | 1200 | 959  | 1200 | 904  |  |
| <b>42</b>             | \$776  | 1009 | 1261 | 1009 | 1261 | 950  |  |
| <b>48</b>             | \$816  | 1059 | 1322 | 1059 | 1322 | 1003 |  |
| <b>54</b>             | \$864  | 1122 | 1402 | 1122 | 1402 | 1064 |  |
| <b>60</b>             | \$916  | 1190 | 1487 | 1190 | 1487 | 1132 |  |
| <b>66</b>             | \$980  | 1273 | 1590 | 1273 | 1590 | 1215 |  |
| <b>72</b>             | \$1049 | 1360 | 1702 | 1360 | 1702 | 1306 |  |



Rectangular Table *continued*

|              |           |           |           |           |           |           |
|--------------|-----------|-----------|-----------|-----------|-----------|-----------|
| 36 42        | \$847     | 1090      | 1372      | —         | —         | 1215      |
| 48           | \$858     | 1082      | 1384      | —         | —         | 1247      |
| 54           | \$938     | 1165      | 1463      | —         | —         | 1348      |
| 60           | \$955     | 1179      | 1476      | —         | —         | 1392      |
| 66           | \$1008    | 1293      | 1627      | —         | —         | 1578      |
| 72           | \$1074    | 1373      | 1728      | —         | —         | 1652      |
|              | <b>WT</b> | <b>WA</b> | <b>WC</b> | <b>WD</b> | <b>PP</b> | <b>PT</b> |
| DT1AS. 18 48 | \$1144    | 1442      | —         | —         | 819       | 1062      |
| 60           | \$1264    | 1592      | —         | —         | 901       | 1169      |
| 72           | \$1369    | 1725      | —         | —         | 973       | 1262      |
| 24 36        | \$1144    | 1442      | 1144      | 1442      | 819       | 1062      |
| 42           | \$1203    | 1518      | 1203      | 1518      | 858       | 1116      |
| 48           | \$1266    | 1596      | 1266      | 1596      | 902       | 1171      |
| 54           | \$1346    | 1696      | 1346      | 1696      | 954       | 1241      |
| 60           | \$1428    | 1801      | 1428      | 1801      | 1014      | 1316      |
| 66           | \$1533    | 1931      | 1533      | 1931      | 1084      | 1409      |
| 72           | \$1644    | 2069      | 1644      | 2069      | 1160      | 1505      |
| 30 36        | \$1192    | 1502      | 1192      | 1502      | 849       | 1104      |
| 42           | \$1252    | 1581      | 1252      | 1581      | 894       | 1160      |
| 48           | \$1319    | 1662      | 1319      | 1662      | 939       | 1218      |
| 54           | \$1401    | 1765      | 1401      | 1765      | 992       | 1290      |
| 60           | \$1489    | 1875      | 1489      | 1875      | 1054      | 1369      |
| 66           | \$1596    | 2010      | 1596      | 2010      | 1127      | 1464      |
| 72           | \$1711    | 2154      | 1711      | 2154      | 1206      | 1566      |
| 36 42        | \$1462    | 1720      | —         | —         | 976       | 1253      |
| 48           | \$1486    | 1750      | —         | —         | 988       | 1244      |
| 54           | \$1591    | 1851      | —         | —         | 1079      | 1341      |
| 60           | \$1637    | 1921      | —         | —         | 1100      | 1356      |
| 66           | \$1961    | 2241      | —         | —         | 1116      | 1460      |
| 72           | \$2176    | 2514      | —         | —         | 1130      | 1578      |
|              |           |           | <b>PA</b> | <b>PC</b> | <b>PD</b> |           |
| DT1AS. 18 48 |           |           | \$1328    | —         | —         |           |
| 60           |           |           | \$1460    | —         | —         |           |
| 72           |           |           | \$1575    | —         | —         |           |
| 24 36        |           |           | \$1328    | 1062      | 1328      |           |
| 42           |           |           | \$1393    | 1116      | 1393      |           |
| 48           |           |           | \$1464    | 1171      | 1464      |           |
| 54           |           |           | \$1551    | 1241      | 1551      |           |
| 60           |           |           | \$1643    | 1316      | 1643      |           |
| 66           |           |           | \$1759    | 1409      | 1759      |           |
| 72           |           |           | \$1881    | 1505      | 1881      |           |

|              |        |           |           |           |           |           |           |
|--------------|--------|-----------|-----------|-----------|-----------|-----------|-----------|
| 30 36        | \$1382 | 1104      | 1382      |           |           |           |           |
| 42           | \$1451 | 1160      | 1451      |           |           |           |           |
| 48           | \$1521 | 1218      | 1521      |           |           |           |           |
| 54           | \$1612 | 1290      | 1612      |           |           |           |           |
| 60           | \$1710 | 1369      | 1710      |           |           |           |           |
| 66           | \$1828 | 1464      | 1828      |           |           |           |           |
| 72           | \$1956 | 1566      | 1956      |           |           |           |           |
| 36 42        | \$1576 | —         | —         |           |           |           |           |
| 48           | \$1592 | —         | —         |           |           |           |           |
| 54           | \$1681 | —         | —         |           |           |           |           |
| 60           | \$1698 | —         | —         |           |           |           |           |
| 66           | \$1852 | —         | —         |           |           |           |           |
| 72           | \$1986 | —         | —         |           |           |           |           |
|              |        | <b>LP</b> | <b>LT</b> | <b>LA</b> | <b>LC</b> | <b>LD</b> | <b>WP</b> |
| DT1AT. 24 36 |        | —         | —         | —         | —         | —         | \$1041    |
| 42           |        | —         | —         | —         | —         | —         | \$1094    |
| 48           |        | —         | —         | —         | —         | —         | \$1155    |
| 54           |        | —         | —         | —         | —         | —         | \$1227    |
| 60           |        | —         | —         | —         | —         | —         | \$1304    |
| 66           |        | —         | —         | —         | —         | —         | \$1400    |
| 72           |        | —         | —         | —         | —         | —         | \$1501    |
| 30 36        |        | —         | —         | —         | —         | —         | \$1084    |
| 42           |        | —         | —         | —         | —         | —         | \$1141    |
| 48           |        | —         | —         | —         | —         | —         | \$1203    |
| 54           |        | —         | —         | —         | —         | —         | \$1277    |
| 60           |        | —         | —         | —         | —         | —         | \$1358    |
| 66           |        | —         | —         | —         | —         | —         | \$1459    |
| 72           |        | —         | —         | —         | —         | —         | \$1566    |
| 36 42        |        | —         | —         | —         | —         | —         | \$1459    |
| 48           |        | —         | —         | —         | —         | —         | \$1496    |
| 54           |        | —         | —         | —         | —         | —         | \$1619    |
| 60           |        | —         | —         | —         | —         | —         | \$1671    |
| 66           |        | —         | —         | —         | —         | —         | \$1894    |
| 72           |        | —         | —         | —         | —         | —         | \$1981    |
|              |        | <b>WT</b> | <b>WA</b> | <b>WC</b> | <b>WD</b> | <b>PP</b> | <b>PT</b> |
| DT1AT. 24 36 |        | \$1375    | 1731      | 1375      | 1731      | 872       | 1132      |
| 42           |        | \$1444    | 1821      | 1444      | 1821      | 915       | 1188      |
| 48           |        | \$1520    | 1914      | 1520      | 1914      | 958       | 1247      |
| 54           |        | \$1616    | 2035      | 1616      | 2035      | 1017      | 1321      |
| 60           |        | \$1714    | 2160      | 1714      | 2160      | 1080      | 1402      |
| 66           |        | \$1839    | 2316      | 1839      | 2316      | 1155      | 1499      |
| 72           |        | \$1974    | 2483      | 1974      | 2483      | 1235      | 1603      |

Everywhere™ Standard-Height Tables

Rectangular Table *continued*

Everywhere™ Standard-Height Tables

|              |        |      |      |      |      |      |
|--------------|--------|------|------|------|------|------|
| <b>30 36</b> | \$1429 | 1804 | 1429 | 1804 | 906  | 1176 |
| <b>42</b>    | \$1502 | 1897 | 1502 | 1897 | 951  | 1235 |
| <b>48</b>    | \$1583 | 1994 | 1583 | 1994 | 1000 | 1298 |
| <b>54</b>    | \$1680 | 2119 | 1680 | 2119 | 1058 | 1376 |
| <b>60</b>    | \$1787 | 2250 | 1787 | 2250 | 1122 | 1458 |
| <b>66</b>    | \$1914 | 2412 | 1914 | 2412 | 1199 | 1560 |
| <b>72</b>    | \$2053 | 2585 | 2053 | 2585 | 1283 | 1668 |
| <b>36 42</b> | \$1754 | 2064 | —    | —    | 1038 | 1336 |
| <b>48</b>    | \$1782 | 2101 | —    | —    | 1053 | 1324 |
| <b>54</b>    | \$1908 | 2220 | —    | —    | 1150 | 1427 |
| <b>60</b>    | \$1965 | 2306 | —    | —    | 1171 | 1447 |
| <b>66</b>    | \$2352 | 2690 | —    | —    | 1214 | 1509 |
| <b>72</b>    | \$2611 | 3015 | —    | —    | 1306 | 1692 |

|              |   |   |   |   |        |      |
|--------------|---|---|---|---|--------|------|
| <b>30 36</b> | — | — | — | — | \$906  | 1176 |
| <b>42</b>    | — | — | — | — | \$951  | 1235 |
| <b>48</b>    | — | — | — | — | \$1000 | 1298 |
| <b>54</b>    | — | — | — | — | \$1058 | 1376 |
| <b>60</b>    | — | — | — | — | \$1122 | 1458 |
| <b>66</b>    | — | — | — | — | \$1199 | 1560 |
| <b>72</b>    | — | — | — | — | \$1283 | 1668 |
| <b>36 42</b> | — | — | — | — | \$1038 | 1336 |
| <b>48</b>    | — | — | — | — | \$1053 | 1324 |
| <b>54</b>    | — | — | — | — | \$1150 | 1427 |
| <b>60</b>    | — | — | — | — | \$1171 | 1447 |
| <b>66</b>    | — | — | — | — | \$1223 | 1591 |
| <b>72</b>    | — | — | — | — | \$1311 | 1701 |

|                     |  | PA     | PC   | PD   |
|---------------------|--|--------|------|------|
| <b>DT1AT. 24 36</b> |  | \$1415 | 1132 | 1415 |
| <b>42</b>           |  | \$1485 | 1188 | 1485 |
| <b>48</b>           |  | \$1560 | 1247 | 1560 |
| <b>54</b>           |  | \$1652 | 1321 | 1652 |
| <b>60</b>           |  | \$1750 | 1402 | 1750 |
| <b>66</b>           |  | \$1874 | 1499 | 1874 |
| <b>72</b>           |  | \$2004 | 1603 | 2004 |
| <b>30 36</b>        |  | \$1471 | 1176 | 1471 |
| <b>42</b>           |  | \$1544 | 1235 | 1544 |
| <b>48</b>           |  | \$1621 | 1298 | 1621 |
| <b>54</b>           |  | \$1718 | 1376 | 1718 |
| <b>60</b>           |  | \$1821 | 1458 | 1821 |
| <b>66</b>           |  | \$1947 | 1560 | 1947 |
| <b>72</b>           |  | \$2084 | 1668 | 2084 |
| <b>36 42</b>        |  | \$1679 | —    | —    |
| <b>48</b>           |  | \$1695 | —    | —    |
| <b>54</b>           |  | \$1792 | —    | —    |
| <b>60</b>           |  | \$1808 | —    | —    |
| <b>66</b>           |  | \$2016 | —    | —    |
| <b>72</b>           |  | \$2117 | —    | —    |

|                     |  | PA     | PC   | PD   |
|---------------------|--|--------|------|------|
| <b>DT1AE. 24 36</b> |  | \$1415 | 1132 | 1415 |
| <b>42</b>           |  | \$1485 | 1188 | 1485 |
| <b>48</b>           |  | \$1560 | 1247 | 1560 |
| <b>54</b>           |  | \$1652 | 1321 | 1652 |
| <b>60</b>           |  | \$1750 | 1402 | 1750 |
| <b>66</b>           |  | \$1874 | 1499 | 1874 |
| <b>72</b>           |  | \$2004 | 1603 | 2004 |
| <b>30 36</b>        |  | \$1471 | 1176 | 1471 |
| <b>42</b>           |  | \$1544 | 1235 | 1544 |
| <b>48</b>           |  | \$1621 | 1298 | 1621 |
| <b>54</b>           |  | \$1718 | 1376 | 1718 |
| <b>60</b>           |  | \$1821 | 1458 | 1821 |
| <b>66</b>           |  | \$1947 | 1560 | 1947 |
| <b>72</b>           |  | \$2084 | 1668 | 2084 |
| <b>36 42</b>        |  | \$1679 | —    | —    |
| <b>48</b>           |  | \$1695 | —    | —    |
| <b>54</b>           |  | \$1792 | —    | —    |
| <b>60</b>           |  | \$1808 | —    | —    |
| <b>66</b>           |  | \$2034 | —    | —    |
| <b>72</b>           |  | \$2117 | —    | —    |

|                     |  | WT | WA | WC | WD | PP     | PT   |
|---------------------|--|----|----|----|----|--------|------|
| <b>DT1AE. 24 36</b> |  | —  | —  | —  | —  | \$872  | 1132 |
| <b>42</b>           |  | —  | —  | —  | —  | \$915  | 1188 |
| <b>48</b>           |  | —  | —  | —  | —  | \$958  | 1247 |
| <b>54</b>           |  | —  | —  | —  | —  | \$1017 | 1321 |
| <b>60</b>           |  | —  | —  | —  | —  | \$1080 | 1402 |
| <b>66</b>           |  | —  | —  | —  | —  | \$1155 | 1499 |
| <b>72</b>           |  | —  | —  | —  | —  | \$1235 | 1603 |

Rectangular Table *continued*

Step 7.

| Top Finish                                     |                     |      |
|--|---------------------|------|
| <i>For laminate top/thermoplastic edge (L)</i> |                     |      |
| <b>76</b>                                      | light brown walnut  | +\$0 |
| <b>91</b>                                      | white               | +\$0 |
| <b>98</b>                                      | studio white        | +\$0 |
| <b>8Q</b>                                      | folkstone grey      | +\$0 |
| <b>CL</b>                                      | cool grey neutral   | +\$0 |
| <b>HF</b>                                      | inner tone light    | +\$0 |
| <b>HM</b>                                      | natural maple       | +\$0 |
| <b>HP</b>                                      | light anigre        | +\$0 |
| <b>HT</b>                                      | inner tone          | +\$0 |
| <b>HX</b>                                      | aged cherry         | +\$0 |
| <b>HY</b>                                      | walnut on cherry    | +\$0 |
| <b>LA</b>                                      | light ash           | +\$0 |
| <b>LBA</b>                                     | clear on ash        | +\$0 |
| <b>LBU</b>                                     | medium matte walnut | +\$0 |
| <b>LBB</b>                                     | oak on ash          | +\$0 |
| <b>LBC</b>                                     | walnut on ash       | +\$0 |
| <b>LBD</b>                                     | dark brown walnut   | +\$0 |
| <b>LBE</b>                                     | medium red walnut   | +\$0 |
| <b>LBF</b>                                     | neutral twill       | +\$0 |
| <b>LBG</b>                                     | sarum twill         | +\$0 |
| <b>LBH</b>                                     | earthen twill       | +\$0 |
| <b>LBJ</b>                                     | graphite twill      | +\$0 |
| <b>LBK</b>                                     | pewter mesh         | +\$0 |
| <b>LBL</b>                                     | steel mesh          | +\$0 |
| <b>LBM</b>                                     | crisp linen         | +\$0 |
| <b>LBN</b>                                     | classic linen       | +\$0 |
| <b>LBP</b>                                     | casual linen        | +\$0 |
| <b>LBQ</b>                                     | white twill         | +\$0 |
| <b>LU</b>                                      | soft white          | +\$0 |
| <b>WL</b>                                      | sandstone           | +\$0 |
| <b>WN</b>                                      | warm grey neutral   | +\$0 |

| Top/Edge Finish: Wood Veneer          |  |       |
|---------------------------------------|--|-------|
| <i>For veneer top/veneer edge (W)</i> |  |       |
| <b>2U</b>                             | light brown walnut <span style="border: 1px solid black; padding: 0 2px;">A</span> | +\$50 |
| <b>40</b>                             | dark brown walnut <span style="border: 1px solid black; padding: 0 2px;">A</span>  | +\$50 |
| <b>ED</b>                             | aged cherry <span style="border: 1px solid black; padding: 0 2px;">A</span>        | +\$50 |
| <b>EK</b>                             | medium red walnut <span style="border: 1px solid black; padding: 0 2px;">A</span>  | +\$50 |
| <b>ET</b>                             | clear on ash <span style="border: 1px solid black; padding: 0 2px;">A</span>       | +\$50 |
| <b>EU</b>                             | oak on ash <span style="border: 1px solid black; padding: 0 2px;">A</span>         | +\$50 |
| <b>EV</b>                             | walnut on ash <span style="border: 1px solid black; padding: 0 2px;">A</span>      | +\$50 |
| <b>UL</b>                             | natural maple <span style="border: 1px solid black; padding: 0 2px;">A</span>      | +\$50 |
| <b>UX</b>                             | walnut on cherry <span style="border: 1px solid black; padding: 0 2px;">A</span>   | +\$50 |

| Top/Edge Finish: Opaque Formcoat®         |                   |      |
|---|-------------------|------|
| <i>For painted Formcoat® top/edge (P)</i> |                   |      |
| <b>8Q</b>                                 | folkstone grey    | +\$0 |
| <b>91</b>                                 | white             | +\$0 |
| <b>CL</b>                                 | cool grey neutral | +\$0 |
| <b>LU</b>                                 | soft white        | +\$0 |
| <b>WL</b>                                 | sandstone         | +\$0 |
| <b>WN</b>                                 | warm grey neutral | +\$0 |

| Step 8. Edge Finish                            |                     |      |
|--|---------------------|------|
| <i>For laminate top/thermoplastic edge (L)</i> |                     |      |
| <b>76</b>                                      | light brown walnut  | +\$0 |
| <b>8Q</b>                                      | folkstone grey      | +\$0 |
| <b>91</b>                                      | white               | +\$0 |
| <b>98</b>                                      | studio white        | +\$0 |
| <b>CL</b>                                      | cool grey neutral   | +\$0 |
| <b>LA</b>                                      | light ash           | +\$0 |
| <b>LBA</b>                                     | clear on ash        | +\$0 |
| <b>LBU</b>                                     | medium matte walnut | +\$0 |
| <b>LBB</b>                                     | oak on ash          | +\$0 |
| <b>LBC</b>                                     | walnut on ash       | +\$0 |
| <b>LBD</b>                                     | dark brown walnut   | +\$0 |
| <b>LBE</b>                                     | medium red walnut   | +\$0 |
| <b>LBF</b>                                     | neutral twill       | +\$0 |
| <b>LBG</b>                                     | sarum twill         | +\$0 |
| <b>LBH</b>                                     | earthen twill       | +\$0 |
| <b>LBJ</b>                                     | graphite twill      | +\$0 |
| <b>LBK</b>                                     | pewter mesh         | +\$0 |
| <b>LBL</b>                                     | steel mesh          | +\$0 |
| <b>LBM</b>                                     | crisp linen         | +\$0 |
| <b>LBN</b>                                     | classic linen       | +\$0 |
| <b>LBP</b>                                     | casual linen        | +\$0 |
| <b>LBQ</b>                                     | white twill         | +\$0 |
| <b>WL</b>                                      | sandstone           | +\$0 |
| <b>WN</b>                                      | warm grey neutral   | +\$0 |
| <b>HF</b>                                      | inner tone light    | +\$0 |
| <b>HM</b>                                      | natural maple       | +\$0 |
| <b>HP</b>                                      | light anigre        | +\$0 |
| <b>HT</b>                                      | inner tone          | +\$0 |
| <b>HX</b>                                      | aged cherry         | +\$0 |
| <b>HY</b>                                      | walnut on cherry    | +\$0 |
| <b>LU</b>                                      | soft white          | +\$0 |
| <b>9V</b>                                      | tapestry beige      | +\$0 |

# Rectangular Table *continued*

Everywhere™ Standard-Height Tables

| Step 9. Leg Finish |  |        |
|--------------------|--|--------|
| <b>8Q</b>          | folkstone grey   | +\$0   |
| <b>91</b>          | white  | +\$0   |
| <b>98</b>          | studio white <span style="border: 1px solid black; padding: 0 2px;">A</span> | +\$0   |
| <b>BU</b>          | black umber  | +\$0   |
| <b>CL</b>          | cool grey neutral  | +\$0   |
| <b>G2</b>          | graphite satin   | +\$0   |
| <b>HF</b>          | inner tone light   | +\$0   |
| <b>LU</b>          | soft white   | +\$0   |
| <b>MT</b>          | medium tone  | +\$0   |
| <b>SG</b>          | slate grey   | +\$0   |
| <b>WL</b>          | sandstone  | +\$0   |
| <b>WN</b>          | warm grey neutral  | +\$0   |
| <b>CN</b>          | metallic champagne   | +\$20  |
| <b>EH</b>          | metallic bronze  | +\$20  |
| <b>MS</b>          | metallic silver  | +\$20  |
| <b>CD</b>          | polished aluminum  | +\$110 |

| Step 10. Casters/Glides |         |      |
|-------------------------|---------|------|
| <b>20</b>               | casters | +\$0 |
| <b>57</b>               | glides  | +\$0 |

| Step 11. Grommets |  |  |
|-------------------|--|--|
|-------------------|--|--|

| <i>For squared-edge (S.) with 18" deep (18)</i> |            |      |
|---|------------|------|
| <b>NTG</b>                                      | no grommet | +\$0 |

| <i>For 24" deep (24), 30" deep (30) AND 36" deep (36)</i> |                                      |       |
|---|--------------------------------------|-------|
| <b>NTG</b>  | no grommet                           | +\$0  |
| <b>253</b>  | cutout for Y1420. or Y1425. - 3 port | +\$27 |
| <b>254</b>  | cutout for Y1420. or Y1425. - 5 port | +\$27 |
| <b>255</b>  | cutout for Y1420. or Y1425. - 6 port | +\$27 |

## Square Table

DT1BE.  
DT1BS.  
DT1BT.

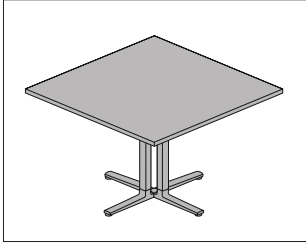

### Product Information

#### Description

This square table comes in multiple edge styles and has a laminate top with thermoplastic edge, laminate top with a thermoplastic backed plywood edge, veneer top and edge, or painted top and edge. It has multiple leg/base options, and is available with casters or glides. The caster option has 2 locking and 2 non-locking casters. Glides have 1/2" leveling range. Shipped knocked down.

#### Notes

48" tops available only with post leg option for optimum stability.

42" top (4242) with 4-column base (X) available only with glides.

Casters are not compatible with this top/base combination.

For additional details on available edge options see Appendices.

For additional size, edge, and finish options, see Vary Easy Program in Appendices.

UL listed when used with Connect™ single circuit electrical product (Y137x.) with post leg (P) option.

### Dimensions

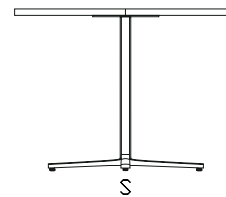
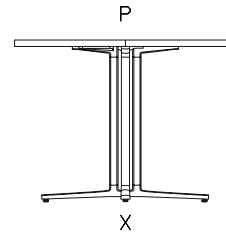
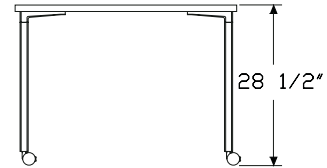
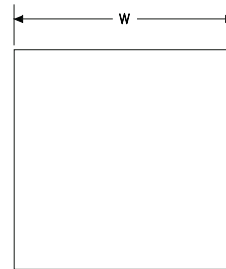

Square Table *continued*

Everywhere™ Standard-Height Tables

**Specification Information**

Step 1.

**DT1B**

Step 2. Edge

- S.** squared-edge
- T.** thin-edge
- E.** eased-edge

Step 3. Depth/Width

- 3030** 30" deep x 30" wide
- 3636** 36" deep x 36" wide
- 4242** 42" deep x 42" wide
- 4848** 48" deep x 48" wide

Step 4. Surface Material

*For squared-edge (S.)*

- L** laminate top/thermoplastic edge
- W** veneer top/veneer edge A
- P** painted Formcoat® top/edge

*For thin-edge (T.)*

- W** veneer top/veneer edge A
- P** painted Formcoat® top/edge

*For eased-edge (E.)*

- P** painted Formcoat® top/edge

Step 5. Leg/Base Type

*For 30" deep x 30" wide (3030)*

- P** post leg
- X** 4-column base
- S** single-column base A

*For 36" deep x 36" wide (3636)*

- P** post leg
- X** 4-column base
- S** single-column base A

*For 42" deep x 42" wide (4242)*

- P** post leg
- X** 4-column base

*For 48" deep x 48" wide (4848)*

- P** post leg

Prices for Steps 1-5.

|                      | P        | X        | S        |
|----------------------|----------|----------|----------|
| <b>DT1BS. 3030 L</b> | \$676    | 878      | 747      |
| <b>W</b>             | \$854    | 1127     | 949      |
| <b>P</b>             | \$778    | 1011     | 858      |
| <b>3636 L</b>        | \$811    | 1053     | 896      |
| <b>W</b>             | \$1037   | 1363     | 1152     |
| <b>P</b>             | \$934    | 1211     | 1029     |
| <b>4242 L</b>        | \$932    | 1210     | —        |
| <b>W</b>             | \$1199   | 1575     | —        |
| <b>P</b>             | \$1071   | 1391     | —        |
| <b>4848 L</b>        | \$1044   | —        | —        |
| <b>W</b>             | \$1407   | —        | —        |
| <b>P</b>             | \$1200   | —        | —        |
|                      | <b>P</b> | <b>X</b> | <b>S</b> |
| <b>DT1BT. 3030 W</b> | \$1024   | 1352     | 1140     |
| <b>P</b>             | \$830    | 1078     | 915      |
| <b>3636 W</b>        | \$1244   | 1636     | 1382     |
| <b>P</b>             | \$993    | 1289     | 1096     |
| <b>4242 W</b>        | \$1439   | 1892     | —        |
| <b>P</b>             | \$1141   | 1483     | —        |
| <b>4848 W</b>        | \$1689   | —        | —        |
| <b>P</b>             | \$1278   | —        | —        |
|                      | <b>P</b> | <b>X</b> | <b>S</b> |
| <b>DT1BE. 3030 P</b> | \$830    | 1078     | 915      |
| <b>3636 P</b>        | \$993    | 1289     | 1096     |
| <b>4242 P</b>        | \$1141   | 1483     | —        |
| <b>4848 P</b>        | \$1278   | —        | —        |

Square Table *continued*

Step 6.

| Top Finish                                     |                     |      |
|--|---------------------|------|
| <i>For laminate top/thermoplastic edge (L)</i> |                     |      |
| <b>76</b>                                      | light brown walnut  | +\$0 |
| <b>91</b>                                      | white               | +\$0 |
| <b>98</b>                                      | studio white        | +\$0 |
| <b>8Q</b>                                      | folkstone grey      | +\$0 |
| <b>CL</b>                                      | cool grey neutral   | +\$0 |
| <b>HF</b>                                      | inner tone light    | +\$0 |
| <b>HM</b>                                      | natural maple       | +\$0 |
| <b>HP</b>                                      | light anigre        | +\$0 |
| <b>HT</b>                                      | inner tone          | +\$0 |
| <b>HX</b>                                      | aged cherry         | +\$0 |
| <b>HY</b>                                      | walnut on cherry    | +\$0 |
| <b>LA</b>                                      | light ash           | +\$0 |
| <b>LBA</b>                                     | clear on ash        | +\$0 |
| <b>LBU</b>                                     | medium matte walnut | +\$0 |
| <b>LBB</b>                                     | oak on ash          | +\$0 |
| <b>LBC</b>                                     | walnut on ash       | +\$0 |
| <b>LBD</b>                                     | dark brown walnut   | +\$0 |
| <b>LBE</b>                                     | medium red walnut   | +\$0 |
| <b>LBF</b>                                     | neutral twill       | +\$0 |
| <b>LBG</b>                                     | sarum twill         | +\$0 |
| <b>LBH</b>                                     | earthen twill       | +\$0 |
| <b>LBJ</b>                                     | graphite twill      | +\$0 |
| <b>LBK</b>                                     | pewter mesh         | +\$0 |
| <b>LBL</b>                                     | steel mesh          | +\$0 |
| <b>LBM</b>                                     | crisp linen         | +\$0 |
| <b>LBN</b>                                     | classic linen       | +\$0 |
| <b>LBP</b>                                     | casual linen        | +\$0 |
| <b>LBQ</b>                                     | white twill         | +\$0 |
| <b>LU</b>                                      | soft white          | +\$0 |
| <b>WL</b>                                      | sandstone           | +\$0 |
| <b>WN</b>                                      | warm grey neutral   | +\$0 |

| Top/Edge Finish: Wood Veneer          |  |       |
|---------------------------------------|--|-------|
| <i>For veneer top/veneer edge (W)</i> |  |       |
| <b>2U</b>                             | light brown walnut <span style="border: 1px solid black; padding: 0 2px;">A</span> | +\$50 |
| <b>40</b>                             | dark brown walnut <span style="border: 1px solid black; padding: 0 2px;">A</span>  | +\$50 |
| <b>ED</b>                             | aged cherry <span style="border: 1px solid black; padding: 0 2px;">A</span>        | +\$50 |
| <b>EK</b>                             | medium red walnut <span style="border: 1px solid black; padding: 0 2px;">A</span>  | +\$50 |
| <b>ET</b>                             | clear on ash <span style="border: 1px solid black; padding: 0 2px;">A</span>       | +\$50 |
| <b>EU</b>                             | oak on ash <span style="border: 1px solid black; padding: 0 2px;">A</span>         | +\$50 |
| <b>EV</b>                             | walnut on ash <span style="border: 1px solid black; padding: 0 2px;">A</span>      | +\$50 |
| <b>UL</b>                             | natural maple <span style="border: 1px solid black; padding: 0 2px;">A</span>      | +\$50 |
| <b>UX</b>                             | walnut on cherry <span style="border: 1px solid black; padding: 0 2px;">A</span>   | +\$50 |

| Top/Edge Finish: Opaque Formcoat®         |                   |      |
|---|-------------------|------|
| <i>For painted Formcoat® top/edge (P)</i> |                   |      |
| <b>8Q</b>                                 | folkstone grey    | +\$0 |
| <b>91</b>                                 | white             | +\$0 |
| <b>CL</b>                                 | cool grey neutral | +\$0 |
| <b>LU</b>                                 | soft white        | +\$0 |
| <b>WL</b>                                 | sandstone         | +\$0 |
| <b>WN</b>                                 | warm grey neutral | +\$0 |

| Step 7. Edge Finish                            |                     |      |
|--|---------------------|------|
| <i>For laminate top/thermoplastic edge (L)</i> |                     |      |
| <b>76</b>                                      | light brown walnut  | +\$0 |
| <b>8Q</b>                                      | folkstone grey      | +\$0 |
| <b>91</b>                                      | white               | +\$0 |
| <b>98</b>                                      | studio white        | +\$0 |
| <b>CL</b>                                      | cool grey neutral   | +\$0 |
| <b>LA</b>                                      | light ash           | +\$0 |
| <b>LBA</b>                                     | clear on ash        | +\$0 |
| <b>LBU</b>                                     | medium matte walnut | +\$0 |
| <b>LBB</b>                                     | oak on ash          | +\$0 |
| <b>LBC</b>                                     | walnut on ash       | +\$0 |
| <b>LBD</b>                                     | dark brown walnut   | +\$0 |
| <b>LBE</b>                                     | medium red walnut   | +\$0 |
| <b>LBF</b>                                     | neutral twill       | +\$0 |
| <b>LBG</b>                                     | sarum twill         | +\$0 |
| <b>LBH</b>                                     | earthen twill       | +\$0 |
| <b>LBJ</b>                                     | graphite twill      | +\$0 |
| <b>LBK</b>                                     | pewter mesh         | +\$0 |
| <b>LBL</b>                                     | steel mesh          | +\$0 |
| <b>LBM</b>                                     | crisp linen         | +\$0 |
| <b>LBN</b>                                     | classic linen       | +\$0 |
| <b>LBP</b>                                     | casual linen        | +\$0 |
| <b>LBQ</b>                                     | white twill         | +\$0 |
| <b>WL</b>                                      | sandstone           | +\$0 |
| <b>WN</b>                                      | warm grey neutral   | +\$0 |
| <b>HF</b>                                      | inner tone light    | +\$0 |
| <b>HM</b>                                      | natural maple       | +\$0 |
| <b>HP</b>                                      | light anigre        | +\$0 |
| <b>HT</b>                                      | inner tone          | +\$0 |
| <b>HX</b>                                      | aged cherry         | +\$0 |
| <b>HY</b>                                      | walnut on cherry    | +\$0 |
| <b>LU</b>                                      | soft white          | +\$0 |

Everywhere™ Standard-Height Tables

# Square Table *continued*

Everywhere™ Standard-Height Tables

| Step 8. Leg Finish     |   |        |
|------------------------|---|--------|
| <b>8Q</b>              | folkstone grey                          | +\$0   |
| <b>91</b>              | white                                   | +\$0   |
| <b>98</b>              | studio white <input type="checkbox"/> A | +\$0   |
| <b>BU</b>              | black umber                             | +\$0   |
| <b>CL</b>              | cool grey neutral                       | +\$0   |
| <b>G2</b>              | graphite satin                          | +\$0   |
| <b>HF</b>              | inner tone light                        | +\$0   |
| <b>LU</b>              | soft white                              | +\$0   |
| <b>MT</b>              | medium tone                             | +\$0   |
| <b>SG</b>              | slate grey                              | +\$0   |
| <b>WL</b>              | sandstone                               | +\$0   |
| <b>WN</b>              | warm grey neutral                       | +\$0   |
| <b>CN</b>              | metallic champagne                      | +\$20  |
| <b>EH</b>              | metallic bronze                         | +\$20  |
| <b>MS</b>              | metallic silver                         | +\$20  |
| <b>CD</b>              | polished aluminum                       | +\$110 |
| Step 9. Casters/Glides |   |        |
| <b>20</b>              | casters                                 | +\$0   |
| <b>57</b>              | glides                                  | +\$0   |
| For 4-column base (X)  |   |        |
| <b>57</b>              | glides                                  | +\$0   |



# Round Table

DT1CE.  
DT1CS.  
DT1CT.

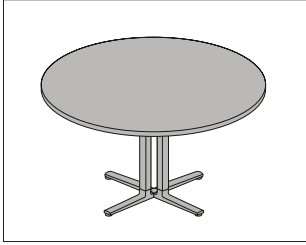

### Product Information

#### Description

This round table comes in multiple edge styles and has a laminate top with thermoplastic edge, veneer top and edge, or painted top and edge. It has multiple leg/base options, and is available with casters or glides. The caster option has 2 locking and 2 non-locking casters. Glides have 1/2" leveling range. Shipped knocked down.

#### Notes

48" and 60" tops available only with post leg option for optimum stability.

For additional details on available edge options see Appendices.

For additional size, edge, and finish options, see Vary Easy Program in Appendices.

UL listed when used with Connect™ single circuit electrical product (Y137x.) with post leg (P) option.

### Dimensions

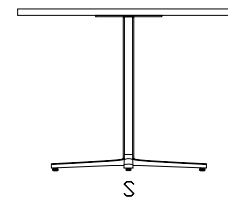
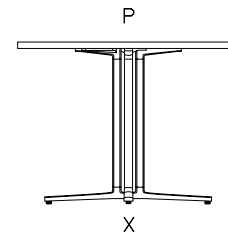
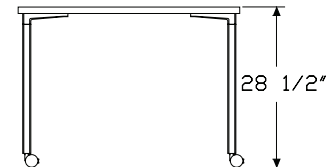
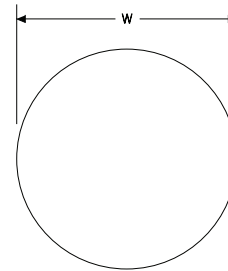

Round Table *continued*

Everywhere™ Standard-Height Tables

**Specification Information**

Step 1.

**DT1C**

Step 2. Edge

- S.** squared-edge
- T.** thin-edge
- E.** eased-edge

Step 3. Diameter

- 30** 30" diameter
- 36** 36" diameter
- 42** 42" diameter
- 48** 48" diameter
- 60** 60" diameter

Step 4. Surface Material

*For squared-edge (S.)*

- L** laminate top/thermoplastic edge
- W** veneer top/veneer edge **A**
- P** painted Formcoat® top/edge

*For thin-edge (T.)*

- W** veneer top/veneer edge **A**
- P** painted Formcoat® top/edge

*For eased-edge (E.)*

- P** painted Formcoat® top/edge

Step 5. Leg/Base Type

*For 30" diameter (30) or 36" diameter (36)*

- P** post leg
- X** 4-column base
- S** single-column base **A**

*For 42" diameter (42)*

- P** post leg
- X** 4-column base

*For 48" diameter (48) or 60" diameter (60)*

- P** post leg

Prices for Steps 1-5.

|                    | P        | X        | S        |
|--------------------|----------|----------|----------|
| <b>DT1CS. 30 L</b> | \$776    | 1011     | 858      |
| <b>W</b>           | \$983    | 1296     | 1091     |
| <b>P</b>           | \$894    | 1162     | 988      |
| <b>36 L</b>        | \$934    | 1210     | 985      |
| <b>W</b>           | \$983    | 1568     | 1323     |
| <b>P</b>           | \$1074   | 1391     | 1133     |
| <b>42 L</b>        | \$1071   | 1330     | —        |
| <b>W</b>           | \$1380   | 1812     | —        |
| <b>P</b>           | \$1232   | 1530     | —        |
| <b>48 L</b>        | \$1199   | —        | —        |
| <b>W</b>           | \$1618   | —        | —        |
| <b>P</b>           | \$1381   | —        | —        |
| <b>60 L</b>        | \$1308   | —        | —        |
| <b>W</b>           | \$1772   | —        | —        |
| <b>P</b>           | \$1502   | —        | —        |
|                    | <b>P</b> | <b>X</b> | <b>S</b> |
| <b>DT1CT. 30 W</b> | \$1179   | 1555     | 1310     |
| <b>P</b>           | \$951    | 1238     | 1053     |
| <b>36 W</b>        | \$1179   | 1881     | 1588     |
| <b>P</b>           | \$1143   | 1483     | 1207     |
| <b>42 W</b>        | \$1655   | 2174     | —        |
| <b>P</b>           | \$1313   | 1630     | —        |
| <b>48 W</b>        | \$1941   | —        | —        |
| <b>P</b>           | \$1469   | —        | —        |
| <b>60 W</b>        | \$2126   | —        | —        |
| <b>P</b>           | \$1601   | —        | —        |
|                    | <b>P</b> | <b>X</b> | <b>S</b> |
| <b>DT1CE. 30 P</b> | \$951    | 1238     | 1053     |
| <b>36 P</b>        | \$1143   | 1483     | 1207     |
| <b>42 P</b>        | \$1313   | 1630     | —        |
| <b>48 P</b>        | \$1469   | —        | —        |
| <b>60 P</b>        | \$1601   | —        | —        |

Step 6.

Top Finish

*For laminate top/thermoplastic edge (L)*

|            |  |      |
|------------|--|------|
| <b>38</b>  | twilight   | +\$0 |
| <b>39</b>  | desert   | +\$0 |
| <b>76</b>  | light brown walnut   | +\$0 |
| <b>91</b>  | white  | +\$0 |
| <b>98</b>  | studio white   | +\$0 |
| <b>8Q</b>  | folkstone grey   | +\$0 |
| <b>CL</b>  | cool grey neutral  | +\$0 |
| <b>HF</b>  | inner tone light   | +\$0 |
| <b>HM</b>  | natural maple  | +\$0 |
| <b>HP</b>  | light anigre   | +\$0 |
| <b>HT</b>  | inner tone <span style="border: 1px solid black; padding: 0 2px;">A</span> | +\$0 |
| <b>HX</b>  | aged cherry  | +\$0 |
| <b>HY</b>  | walnut on cherry   | +\$0 |
| <b>LA</b>  | light ash  | +\$0 |
| <b>LBA</b> | clear on ash   | +\$0 |
| <b>LBU</b> | medium matte walnut  | +\$0 |
| <b>LBB</b> | oak on ash   | +\$0 |
| <b>LBC</b> | walnut on ash  | +\$0 |
| <b>LBD</b> | dark brown walnut  | +\$0 |
| <b>LBE</b> | medium red walnut  | +\$0 |
| <b>LBF</b> | neutral twill  | +\$0 |
| <b>LBG</b> | sarum twill  | +\$0 |
| <b>LBH</b> | earthen twill  | +\$0 |
| <b>LBJ</b> | graphite twill   | +\$0 |
| <b>LBK</b> | pewter mesh  | +\$0 |
| <b>LBL</b> | steel mesh   | +\$0 |
| <b>LBM</b> | crisp linen  | +\$0 |
| <b>LBN</b> | classic linen  | +\$0 |
| <b>LBP</b> | casual linen   | +\$0 |
| <b>LBQ</b> | white twill  | +\$0 |
| <b>LU</b>  | soft white   | +\$0 |
| <b>WL</b>  | sandstone  | +\$0 |
| <b>WN</b>  | warm grey neutral  | +\$0 |

Top/Edge Finish: Wood Veneer

*For veneer top/veneer edge (W)*

|           |  |       |
|-----------|--|-------|
| <b>2U</b> | light brown walnut <span style="border: 1px solid black; padding: 0 2px;">A</span> | +\$50 |
| <b>40</b> | dark brown walnut <span style="border: 1px solid black; padding: 0 2px;">A</span>  | +\$50 |
| <b>ED</b> | aged cherry <span style="border: 1px solid black; padding: 0 2px;">A</span>        | +\$50 |
| <b>EK</b> | medium red walnut <span style="border: 1px solid black; padding: 0 2px;">A</span>  | +\$50 |
| <b>ET</b> | clear on ash <span style="border: 1px solid black; padding: 0 2px;">A</span>       | +\$50 |
| <b>EU</b> | oak on ash <span style="border: 1px solid black; padding: 0 2px;">A</span>         | +\$50 |
| <b>EV</b> | walnut on ash <span style="border: 1px solid black; padding: 0 2px;">A</span>      | +\$50 |
| <b>UL</b> | natural maple <span style="border: 1px solid black; padding: 0 2px;">A</span>      | +\$50 |
| <b>UX</b> | walnut on cherry <span style="border: 1px solid black; padding: 0 2px;">A</span>   | +\$50 |

Top/Edge Finish: Opaque Formcoat®

*For painted Formcoat® top/edge (P)*

|           |                   |      |
|-----------|-------------------|------|
| <b>8Q</b> | folkstone grey    | +\$0 |
| <b>91</b> | white             | +\$0 |
| <b>CL</b> | cool grey neutral | +\$0 |
| <b>LU</b> | soft white        | +\$0 |
| <b>WL</b> | sandstone         | +\$0 |
| <b>WN</b> | warm grey neutral | +\$0 |

# Round Table *continued*

Everywhere™ Standard-Height Tables

| Step 7. Edge Finish                            |  |      |
|--|--|------|
| <i>For laminate top/thermoplastic edge (L)</i> |  |      |
| <b>76</b>                                      | light brown walnut   | +\$0 |
| <b>8Q</b>                                      | folkstone grey   | +\$0 |
| <b>91</b>                                      | white  | +\$0 |
| <b>98</b>                                      | studio white   | +\$0 |
| <b>CL</b>                                      | cool grey neutral  | +\$0 |
| <b>LA</b>                                      | light ash  | +\$0 |
| <b>LBA</b>                                     | clear on ash   | +\$0 |
| <b>LBU</b>                                     | medium matte walnut  | +\$0 |
| <b>LBB</b>                                     | oak on ash   | +\$0 |
| <b>LBC</b>                                     | walnut on ash  | +\$0 |
| <b>LBD</b>                                     | dark brown walnut  | +\$0 |
| <b>LBE</b>                                     | medium red walnut  | +\$0 |
| <b>LBF</b>                                     | neutral twill  | +\$0 |
| <b>LBG</b>                                     | sarum twill  | +\$0 |
| <b>LBH</b>                                     | earthen twill  | +\$0 |
| <b>LBJ</b>                                     | graphite twill   | +\$0 |
| <b>LBK</b>                                     | pewter mesh  | +\$0 |
| <b>LBL</b>                                     | steel mesh   | +\$0 |
| <b>LBM</b>                                     | crisp linen  | +\$0 |
| <b>LBN</b>                                     | classic linen  | +\$0 |
| <b>LBP</b>                                     | casual linen   | +\$0 |
| <b>LBQ</b>                                     | white twill  | +\$0 |
| <b>WL</b>                                      | sandstone  | +\$0 |
| <b>WN</b>                                      | warm grey neutral  | +\$0 |
| <b>HF</b>                                      | inner tone light   | +\$0 |
| <b>HM</b>                                      | natural maple  | +\$0 |
| <b>HP</b>                                      | light anigre   | +\$0 |
| <b>HT</b>                                      | inner tone <span style="border: 1px solid black; padding: 0 2px;">A</span> | +\$0 |
| <b>HX</b>                                      | aged cherry  | +\$0 |
| <b>HY</b>                                      | walnut on cherry   | +\$0 |
| <b>LU</b>                                      | soft white   | +\$0 |

| Step 8. Leg/Base Finish |  |        |
|-------------------------|--|--------|
| <b>8Q</b>               | folkstone grey   | +\$0   |
| <b>91</b>               | white  | +\$0   |
| <b>98</b>               | studio white <span style="border: 1px solid black; padding: 0 2px;">A</span> | +\$0   |
| <b>BU</b>               | black umber  | +\$0   |
| <b>CL</b>               | cool grey neutral  | +\$0   |
| <b>G2</b>               | graphite satin   | +\$0   |
| <b>HF</b>               | inner tone light   | +\$0   |
| <b>LU</b>               | soft white   | +\$0   |
| <b>MT</b>               | medium tone  | +\$0   |
| <b>SG</b>               | slate grey   | +\$0   |
| <b>WL</b>               | sandstone  | +\$0   |
| <b>WN</b>               | warm grey neutral  | +\$0   |
| <b>CN</b>               | metallic champagne   | +\$20  |
| <b>EH</b>               | metallic bronze  | +\$20  |
| <b>MS</b>               | metallic silver  | +\$20  |
| <b>CD</b>               | polished aluminum  | +\$110 |

| Step 9. Casters/Glides |         |      |
|------------------------|---------|------|
| <b>20</b>              | casters | +\$0 |
| <b>57</b>              | glides  | +\$0 |

# Oval Table

DT1DE.  
DT1DS.  
DT1DT.

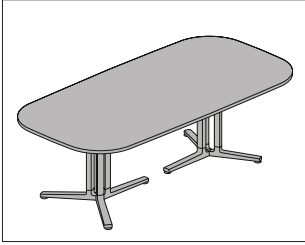

## Product Information

### Description

This oval table comes in multiple edge styles and has a laminate top with thermoplastic edge, veneer top and edge, or painted top and edge. It has multiple leg/base options, and is available with casters or glides. The caster option has 2 locking and 2 non-locking casters. Glides have 1/2" leveling range. Shipped knocked down.

### Notes

When specifying grommets (253, 254, 255), cutouts will be located in the center of table.

Cutouts available for all Connect™ power and data accessories (see Thrive® Portfolio). Cutouts will be located in the center, laterally and front to back.

For additional details on available edge options see Appendices.

For additional size, edge, and finish options, see Vary Easy Program in Appendices.

## Dimensions

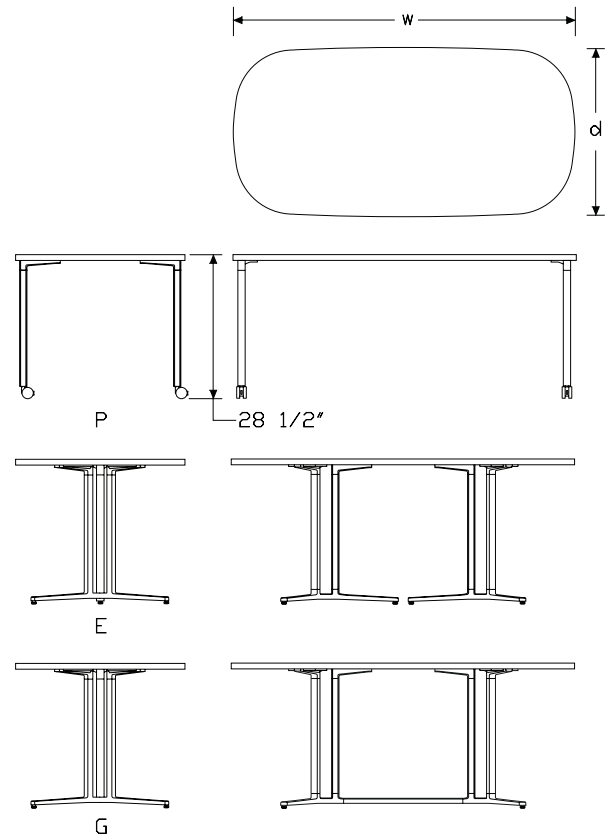

Everywhere™ Standard-Height Tables

Oval Table *continued*

| Specification Information                 |                                 |
|---|---------------------------------|
| Step 1.                                   |                                 |
| <b>DT1D</b>                               |                                 |
| Step 2. Edge                              |                                 |
| <b>S.</b>                                 | squared-edge                    |
| <b>T.</b>                                 | thin-edge                       |
| <b>E.</b>                                 | eased-edge                      |
| Step 3. Depth                             |                                 |
| <b>30</b>                                 | 30" deep                        |
| <b>36</b>                                 | 36" deep                        |
| <b>42</b>                                 | 42" deep                        |
| Step 4. Width                             |                                 |
| <i>For 30" deep (30)</i>                  |                                 |
| <b>48</b>                                 | 48" wide                        |
| <b>60</b>                                 | 60" wide                        |
| <i>For 36" deep (36)</i>                  |                                 |
| <b>60</b>                                 | 60" wide                        |
| <b>72</b>                                 | 72" wide                        |
| <i>For 42" deep (42)</i>                  |                                 |
| <b>72</b>                                 | 72" wide                        |
| <b>84</b>                                 | 84" wide                        |
| Step 5. Surface Material                  |                                 |
| <i>For squared-edge (S.)</i>              |                                 |
| <b>L</b>                                  | lamine top/thermoplastic edge   |
| <b>W</b>                                  | veneer top/veneer edge <b>A</b> |
| <b>P</b>                                  | painted Formcoat® top/edge      |
| <i>For thin-edge (T.)</i>                 |                                 |
| <b>W</b>                                  | veneer top/veneer edge <b>A</b> |
| <b>P</b>                                  | painted Formcoat® top/edge      |
| <i>For eased-edge (E.)</i>                |                                 |
| <b>P</b>                                  | painted Formcoat® top/edge      |
| Step 6. Leg/Base Type                     |                                 |
| <i>For 48" wide (48) or 60" wide (60)</i> |                                 |
| <b>P</b>                                  | post leg                        |
| <b>G</b>                                  | double 3-column base, spanner   |

| <i>For 72" wide (72) or 84" wide (84)</i> |                               |           |           |           |           |           |           |
|---|-------------------------------|-----------|-----------|-----------|-----------|-----------|-----------|
| <b>P</b>                                  | post leg                      |           |           |           |           |           |           |
| <b>E</b>                                  | double 3-column base          |           |           |           |           |           |           |
| <b>G</b>                                  | double 3-column base, spanner |           |           |           |           |           |           |
| Prices for Steps 1-6.                     |                               |           |           |           |           |           |           |
|   |                               | <b>LP</b> | <b>LE</b> | <b>LG</b> | <b>WP</b> | <b>WE</b> | <b>WG</b> |
| <b>DT1DS. 30</b>                          | <b>48</b>                     | \$910     | —         | 1500      | 1350      | —         | 2268      |
|   | <b>60</b>                     | \$983     | —         | 1621      | 1463      | —         | 2453      |
|   | <b>36 60</b>                  | \$1091    | —         | 1800      | 1633      | —         | 2732      |
|   | <b>72</b>                     | \$1254    | 2132      | 2070      | 1886      | 3247      | 3151      |
|   | <b>42 72</b>                  | \$1344    | 2280      | 2214      | 2023      | 3480      | 3377      |
|   | <b>84</b>                     | \$1382    | 2345      | 2276      | 2081      | 3578      | 3474      |
|   |                               |           |           |           | <b>PP</b> | <b>PE</b> | <b>PG</b> |
| <b>DT1DS. 30</b>                          | <b>48</b>                     |           |           |           | \$1047    | —         | 1727      |
|   | <b>60</b>                     |           |           |           | \$1130    | —         | 1864      |
|   | <b>36 60</b>                  |           |           |           | \$1254    | —         | 2070      |
|   | <b>72</b>                     |           |           |           | \$1444    | 2452      | 2381      |
|   | <b>42 72</b>                  |           |           |           | \$1545    | 2623      | 2547      |
|   | <b>84</b>                     |           |           |           | \$1588    | 2697      | 2618      |
|   |                               | <b>LP</b> | <b>LE</b> | <b>LG</b> | <b>WP</b> | <b>WE</b> | <b>WG</b> |
| <b>DT1DT. 30</b>                          | <b>48</b>                     | —         | —         | —         | \$1621    | —         | 2720      |
|   | <b>60</b>                     | —         | —         | —         | \$1755    | —         | 2943      |
|   | <b>36 60</b>                  | —         | —         | —         | \$1960    | —         | 3278      |
|   | <b>72</b>                     | —         | —         | —         | \$2264    | 3897      | 3782      |
|   | <b>42 72</b>                  | —         | —         | —         | \$2428    | 4176      | 4051      |
|   | <b>84</b>                     | —         | —         | —         | \$2497    | 4295      | 4168      |
|   |                               |           |           |           | <b>PP</b> | <b>PE</b> | <b>PG</b> |
| <b>DT1DT. 30</b>                          | <b>48</b>                     |           |           |           | \$1115    | —         | 1838      |
|   | <b>60</b>                     |           |           |           | \$1204    | —         | 1984      |
|   | <b>36 60</b>                  |           |           |           | \$1337    | —         | 2205      |
|   | <b>72</b>                     |           |           |           | \$1537    | 2611      | 2535      |
|   | <b>42 72</b>                  |           |           |           | \$1645    | 2793      | 2712      |
|   | <b>84</b>                     |           |           |           | \$1693    | 2872      | 2788      |
|   |                               |           |           |           | <b>PP</b> | <b>PE</b> | <b>PG</b> |
| <b>DT1DE. 30</b>                          | <b>48</b>                     |           |           |           | \$1115    | —         | 1838      |
|   | <b>60</b>                     |           |           |           | \$1204    | —         | 1984      |
|   | <b>36 60</b>                  |           |           |           | \$1337    | —         | 2205      |
|   | <b>72</b>                     |           |           |           | \$1537    | 2611      | 2535      |
|   | <b>42 72</b>                  |           |           |           | \$1645    | 2793      | 2712      |
|   | <b>84</b>                     |           |           |           | \$1693    | 2872      | 2788      |

Step 7.

Top Finish

*For laminate top/thermoplastic edge (L)*

|            |  |      |
|------------|--|------|
| <b>1X</b>  | vanilla  | +\$0 |
| <b>28</b>  | canyon   | +\$0 |
| <b>29</b>  | misted   | +\$0 |
| <b>2X</b>  | wheat  | +\$0 |
| <b>38</b>  | twilight   | +\$0 |
| <b>39</b>  | desert   | +\$0 |
| <b>3X</b>  | celery   | +\$0 |
| <b>4X</b>  | coriander  | +\$0 |
| <b>5X</b>  | chamomile  | +\$0 |
| <b>6X</b>  | cinnamon   | +\$0 |
| <b>76</b>  | light brown walnut   | +\$0 |
| <b>7X</b>  | cardamom   | +\$0 |
| <b>8Q</b>  | folkstone grey   | +\$0 |
| <b>8X</b>  | kale   | +\$0 |
| <b>91</b>  | white  | +\$0 |
| <b>98</b>  | studio white   | +\$0 |
| <b>CL</b>  | cool grey neutral  | +\$0 |
| <b>HF</b>  | inner tone light   | +\$0 |
| <b>HM</b>  | natural maple  | +\$0 |
| <b>HP</b>  | light anigre   | +\$0 |
| <b>HT</b>  | inner tone <span style="border: 1px solid black; padding: 0 2px;">A</span> | +\$0 |
| <b>HX</b>  | aged cherry  | +\$0 |
| <b>HY</b>  | walnut on cherry   | +\$0 |
| <b>J4</b>  | frosted light grey   | +\$0 |
| <b>J5</b>  | frosted inner tone light   | +\$0 |
| <b>J7</b>  | frosted medium tone  | +\$0 |
| <b>LA</b>  | light ash  | +\$0 |
| <b>LBA</b> | clear on ash   | +\$0 |
| <b>LBB</b> | oak on ash   | +\$0 |
| <b>LBC</b> | walnut on ash  | +\$0 |
| <b>LBD</b> | dark brown walnut  | +\$0 |
| <b>LBE</b> | medium red walnut  | +\$0 |
| <b>LBF</b> | neutral twill  | +\$0 |
| <b>LBG</b> | sarum twill  | +\$0 |
| <b>LBH</b> | earthen twill  | +\$0 |
| <b>LBJ</b> | graphite twill   | +\$0 |
| <b>LBK</b> | pewter mesh  | +\$0 |
| <b>LBL</b> | steel mesh   | +\$0 |
| <b>LBM</b> | crisp linen  | +\$0 |
| <b>LBN</b> | classic linen  | +\$0 |
| <b>LBP</b> | casual linen   | +\$0 |
| <b>LBQ</b> | white twill  | +\$0 |
| <b>LBU</b> | medium matte walnut  | +\$0 |

|           |  |      |
|-----------|--|------|
| <b>LG</b> | light grey (discontinuing) <span style="border: 1px solid black; padding: 0 2px;">A</span> | +\$0 |
| <b>LM</b> | mahogany   | +\$0 |
| <b>LT</b> | light tone <span style="border: 1px solid black; padding: 0 2px;">A</span>                 | +\$0 |
| <b>LU</b> | soft white   | +\$0 |
| <b>MT</b> | medium tone  | +\$0 |
| <b>OG</b> | honey maple <span style="border: 1px solid black; padding: 0 2px;">A</span>                | +\$0 |
| <b>WL</b> | sandstone  | +\$0 |
| <b>WN</b> | warm grey neutral  | +\$0 |
| <b>X1</b> | chalk white <span style="border: 1px solid black; padding: 0 2px;">A</span>                | +\$0 |

Top/Edge Finish: Wood Veneer

*For veneer top/veneer edge (W)*

|           |  |       |
|-----------|--|-------|
| <b>2U</b> | light brown walnut <span style="border: 1px solid black; padding: 0 2px;">A</span> | +\$50 |
| <b>40</b> | dark brown walnut <span style="border: 1px solid black; padding: 0 2px;">A</span>  | +\$50 |
| <b>ED</b> | aged cherry <span style="border: 1px solid black; padding: 0 2px;">A</span>        | +\$50 |
| <b>EK</b> | medium red walnut <span style="border: 1px solid black; padding: 0 2px;">A</span>  | +\$50 |
| <b>ET</b> | clear on ash <span style="border: 1px solid black; padding: 0 2px;">A</span>       | +\$50 |
| <b>EU</b> | oak on ash <span style="border: 1px solid black; padding: 0 2px;">A</span>         | +\$50 |
| <b>EV</b> | walnut on ash <span style="border: 1px solid black; padding: 0 2px;">A</span>      | +\$50 |
| <b>UL</b> | natural maple <span style="border: 1px solid black; padding: 0 2px;">A</span>      | +\$50 |
| <b>UX</b> | walnut on cherry <span style="border: 1px solid black; padding: 0 2px;">A</span>   | +\$50 |

Top/Edge Finish: Opaque Formcoat®

*For painted Formcoat® top/edge (P)*

|           |                   |      |
|-----------|-------------------|------|
| <b>8Q</b> | folkstone grey    | +\$0 |
| <b>91</b> | white             | +\$0 |
| <b>CL</b> | cool grey neutral | +\$0 |
| <b>LU</b> | soft white        | +\$0 |
| <b>WL</b> | sandstone         | +\$0 |
| <b>WN</b> | warm grey neutral | +\$0 |

Step 8. Edge Finish

*For laminate top/thermoplastic edge (L)*

|           |   |      |
|-----------|---|------|
| <b>28</b> | canyon  | +\$0 |
| <b>29</b> | misted  | +\$0 |
| <b>38</b> | twilight  | +\$0 |
| <b>39</b> | desert  | +\$0 |
| <b>76</b> | light brown walnut  | +\$0 |
| <b>8Q</b> | folkstone grey  | +\$0 |
| <b>8Z</b> | neutral grey  | +\$0 |
| <b>91</b> | white   | +\$0 |
| <b>98</b> | studio white  | +\$0 |
| <b>9V</b> | tapestry beige  | +\$0 |
| <b>BU</b> | black umber <span style="border: 1px solid black; padding: 0 2px;">A</span> | +\$0 |
| <b>CL</b> | cool grey neutral   | +\$0 |
| <b>CM</b> | cinnamon  | +\$0 |
| <b>CO</b> | chamomile   | +\$0 |

# Oval Table *continued*

Everywhere™ Standard-Height Tables

|            |                                     |      |
|------------|-------------------------------------|------|
| <b>G2</b>  | graphite satin                      | +\$0 |
| <b>HF</b>  | inner tone light                    | +\$0 |
| <b>HM</b>  | natural maple                       | +\$0 |
| <b>HP</b>  | light anigre                        | +\$0 |
| <b>HT</b>  | inner tone <b>A</b>                 | +\$0 |
| <b>HX</b>  | aged cherry                         | +\$0 |
| <b>HY</b>  | walnut on cherry                    | +\$0 |
| <b>JB</b>  | millwork cherry                     | +\$0 |
| <b>LA</b>  | light ash                           | +\$0 |
| <b>LBA</b> | clear on ash                        | +\$0 |
| <b>LBB</b> | oak on ash                          | +\$0 |
| <b>LBC</b> | walnut on ash                       | +\$0 |
| <b>LBD</b> | dark brown walnut                   | +\$0 |
| <b>LBE</b> | medium red walnut                   | +\$0 |
| <b>LBF</b> | neutral twill                       | +\$0 |
| <b>LBG</b> | sarum twill                         | +\$0 |
| <b>LBH</b> | earthen twill                       | +\$0 |
| <b>LBJ</b> | graphite twill                      | +\$0 |
| <b>LBK</b> | pewter mesh                         | +\$0 |
| <b>LBL</b> | steel mesh                          | +\$0 |
| <b>LBM</b> | crisp linen                         | +\$0 |
| <b>LBN</b> | classic linen                       | +\$0 |
| <b>LBP</b> | casual linen                        | +\$0 |
| <b>LBQ</b> | white twill                         | +\$0 |
| <b>LBU</b> | medium matte walnut                 | +\$0 |
| <b>LG</b>  | light grey (discontinuing) <b>A</b> | +\$0 |
| <b>LM</b>  | mahogany                            | +\$0 |
| <b>LT</b>  | light tone <b>A</b>                 | +\$0 |
| <b>LU</b>  | soft white                          | +\$0 |
| <b>MT</b>  | medium tone                         | +\$0 |
| <b>N3</b>  | cool grey                           | +\$0 |
| <b>OG</b>  | honey maple <b>A</b>                | +\$0 |
| <b>SG</b>  | slate grey                          | +\$0 |
| <b>WA</b>  | wheat                               | +\$0 |
| <b>WL</b>  | sandstone                           | +\$0 |
| <b>WN</b>  | warm grey neutral                   | +\$0 |
| <b>X1</b>  | chalk white <b>A</b>                | +\$0 |

| Step 9. Leg/Base Finish |                       |        |
|-------------------------|-----------------------|--------|
| <b>8Q</b>               | folkstone grey        | +\$0   |
| <b>91</b>               | white                 | +\$0   |
| <b>98</b>               | studio white <b>A</b> | +\$0   |
| <b>BU</b>               | black umber           | +\$0   |
| <b>CL</b>               | cool grey neutral     | +\$0   |
| <b>G2</b>               | graphite satin        | +\$0   |
| <b>HF</b>               | inner tone light      | +\$0   |
| <b>LU</b>               | soft white            | +\$0   |
| <b>MT</b>               | medium tone           | +\$0   |
| <b>SG</b>               | slate grey            | +\$0   |
| <b>WL</b>               | sandstone             | +\$0   |
| <b>WN</b>               | warm grey neutral     | +\$0   |
| <b>CN</b>               | metallic champagne    | +\$20  |
| <b>EH</b>               | metallic bronze       | +\$20  |
| <b>MS</b>               | metallic silver       | +\$20  |
| <b>CD</b>               | polished aluminum     | +\$110 |

| Step 10. Casters/Glides |         |      |
|-------------------------|---------|------|
| <b>20</b>               | casters | +\$0 |
| <b>57</b>               | glides  | +\$0 |

| Step 11. Grommets |                                      |       |
|-------------------|--------------------------------------|-------|
| <b>NTG</b>        | no grommet                           | +\$0  |
| <b>253</b>        | cutout for Y1420. or Y1425. - 3 port | +\$27 |
| <b>254</b>        | cutout for Y1420. or Y1425. - 5 port | +\$27 |
| <b>255</b>        | cutout for Y1420. or Y1425. - 6 port | +\$27 |



## D-Shaped Table

DT1EE.  
DT1ES.  
DT1ET.

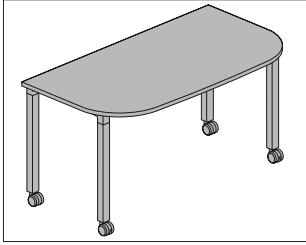

### Product Information

#### Description

This D-shaped table comes in multiple edge styles and has a laminate top with thermoplastic edge, veneer top and edge, or painted top and edge. It has multiple leg options, and is available with casters or glides. The caster option has 2 locking and 2 non-locking casters. Glides have  $\frac{1}{2}$ " leveling range. Shipped knocked down.

Height-adjustable legs have a 5" range in 1" increments.

#### Notes

Thin edge and eased edge tops available only with 30" deep surfaces. T-leg and T-leg with height adjustment cannot be used with 18" deep tops.

Cable grommet options available through Vary Easy Program for round pass through grommet with  $2\frac{1}{4}$ " hole clearance. Holes are located 3" from rear edge and 6" from end for the L and R options. Covers not provided with painted surface option.

Cutouts available for all Connect™ power and data accessories (see Thrive® Portfolio). Cutouts will be located in the center, laterally, and approximately 3" from the rear edge of surface.

Reinforcement channels are used under table tops 54" and wider. They will be located along the center line for 18" deep and 24" deep surfaces, and 19" from the front edge for 30" deep surfaces.

For additional details on available edge options see Appendices.

For additional size, edge, and finish options, see Vary Easy Program in Appendices.

UL listed when used with Connect single circuit electrical product (Y137x.) with post leg (P) and T-leg (T) options.

### Dimensions

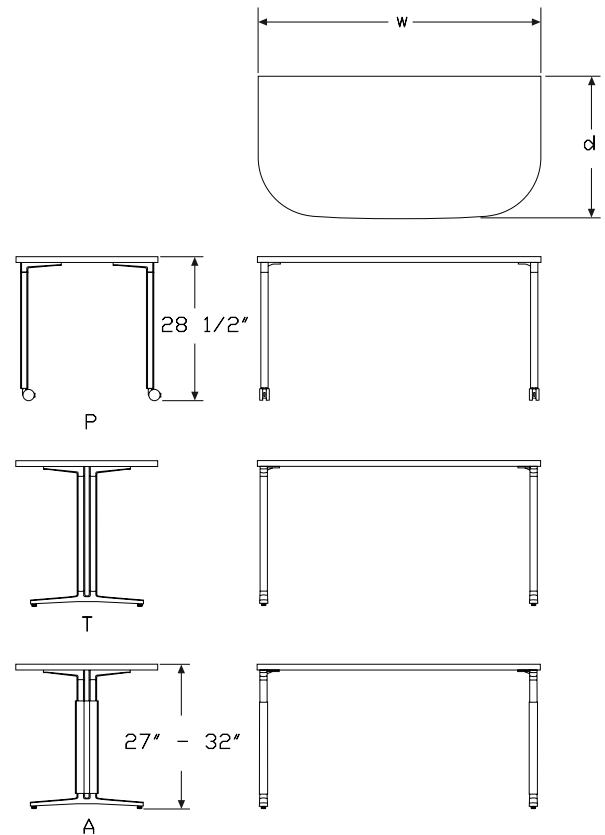

# D-Shaped Table *continued*

## Specification Information

### Step 1.

**DT1E**

### Step 2. Edge

- S.** squared-edge
- T.** thin-edge
- E.** eased-edge

### Step 3. Depth/Width

*For thin-edge (T.) or eased-edge (E.)*

**3060** 30" deep x 60" wide

*For squared-edge (S.)*

**1836** 18" deep x 36" wide

**2448** 24" deep x 48" wide

**3060** 30" deep x 60" wide

### Step 4. Surface Material

*For squared-edge (S.)*

- L** laminate top/thermoplastic edge
- W** veneer top/veneer edge **A**
- P** painted Formcoat® top/edge

*For thin-edge (T.)*

- W** veneer top/veneer edge **A**
- P** painted Formcoat® top/edge

*For eased-edge (E.)*

- P** painted Formcoat® top/edge

### Step 5. Leg Type

*For 18" deep x 36" wide (1836)*

- P** post leg

*For 30" deep x 60" wide (3060) or 24" deep x 48" wide (2448)*

- P** post leg
- T** T-leg
- A** T-leg with height adjustment

## Prices for Steps 1-5.

|                      | P        | T        | A        |
|----------------------|----------|----------|----------|
| <b>DT1ES. 1836 L</b> | \$710    | —        | —        |
| <b>W</b>             | \$827    | —        | —        |
| <b>P</b>             | \$817    | —        | —        |
| <b>2448 L</b>        | \$851    | 1337     | 1619     |
| <b>W</b>             | \$1004   | 1505     | 1912     |
| <b>P</b>             | \$980    | 1537     | 1861     |
| <b>3060 L</b>        | \$979    | 1536     | 1860     |
| <b>W</b>             | \$1162   | 1749     | 2221     |
| <b>P</b>             | \$1126   | 1766     | 2138     |
|                      | <b>P</b> | <b>T</b> | <b>A</b> |
| <b>DT1ET. 3060 W</b> | \$1394   | 2100     | 2666     |
| <b>P</b>             | \$1198   | 1881     | 2278     |

|                      | P      | T    | A    |
|----------------------|--------|------|------|
| <b>DT1EE. 3060 P</b> | \$1198 | 1881 | 2278 |

## Step 6.

### Top Finish

*For laminate top/thermoplastic edge (L)*

|           |                    |      |
|-----------|--------------------|------|
| <b>28</b> | canyon             | +\$0 |
| <b>29</b> | misted             | +\$0 |
| <b>38</b> | twilight           | +\$0 |
| <b>39</b> | desert             | +\$0 |
| <b>76</b> | light brown walnut | +\$0 |
| <b>91</b> | white              | +\$0 |
| <b>98</b> | studio white       | +\$0 |
| <b>1X</b> | vanilla            | +\$0 |
| <b>2X</b> | wheat              | +\$0 |
| <b>3X</b> | celery             | +\$0 |
| <b>4X</b> | coriander          | +\$0 |
| <b>5X</b> | chamomile          | +\$0 |
| <b>6X</b> | cinnamon           | +\$0 |
| <b>7X</b> | cardamom           | +\$0 |
| <b>8X</b> | kale               | +\$0 |
| <b>8Q</b> | folkstone grey     | +\$0 |
| <b>CL</b> | cool grey neutral  | +\$0 |
| <b>HF</b> | inner tone light   | +\$0 |
| <b>HM</b> | natural maple      | +\$0 |
| <b>HP</b> | light anigre       | +\$0 |
| <b>HT</b> | inner tone         | +\$0 |
| <b>HX</b> | aged cherry        | +\$0 |
| <b>HY</b> | walnut on cherry   | +\$0 |
| <b>J4</b> | frosted light grey | +\$0 |

D-Shaped Table *continued*

|            |                            |      |
|------------|----------------------------|------|
| <b>J5</b>  | frosted inner tone light   | +\$0 |
| <b>J7</b>  | frosted medium tone        | +\$0 |
| <b>LA</b>  | light ash                  | +\$0 |
| <b>LBA</b> | clear on ash               | +\$0 |
| <b>LBU</b> | medium matte walnut        | +\$0 |
| <b>LBB</b> | oak on ash                 | +\$0 |
| <b>LBC</b> | walnut on ash              | +\$0 |
| <b>LBD</b> | dark brown walnut          | +\$0 |
| <b>LBE</b> | medium red walnut          | +\$0 |
| <b>LBF</b> | neutral twill              | +\$0 |
| <b>LBG</b> | sarum twill                | +\$0 |
| <b>LBH</b> | earthen twill              | +\$0 |
| <b>LBJ</b> | graphite twill             | +\$0 |
| <b>LBK</b> | pewter mesh                | +\$0 |
| <b>LBL</b> | steel mesh                 | +\$0 |
| <b>LBM</b> | crisp linen                | +\$0 |
| <b>LBN</b> | classic linen              | +\$0 |
| <b>LBP</b> | casual linen               | +\$0 |
| <b>LBQ</b> | white twill                | +\$0 |
| <b>LG</b>  | light grey (discontinuing) | +\$0 |
| <b>LM</b>  | mahogany                   | +\$0 |
| <b>LT</b>  | light tone                 | +\$0 |
| <b>LU</b>  | soft white                 | +\$0 |
| <b>MT</b>  | medium tone                | +\$0 |
| <b>OG</b>  | honey maple                | +\$0 |
| <b>WL</b>  | sandstone                  | +\$0 |
| <b>WN</b>  | warm grey neutral          | +\$0 |
| <b>X1</b>  | chalk white                | +\$0 |

Top/Edge Finish: Wood Veneer

*For veneer top/veneer edge (W)*

|           |   |       |
|-----------|---|-------|
| <b>2U</b> | light brown walnut <input type="checkbox"/> | +\$50 |
| <b>40</b> | dark brown walnut <input type="checkbox"/>  | +\$50 |
| <b>ED</b> | aged cherry <input type="checkbox"/>        | +\$50 |
| <b>EK</b> | medium red walnut <input type="checkbox"/>  | +\$50 |
| <b>ET</b> | clear on ash <input type="checkbox"/>       | +\$50 |
| <b>EU</b> | oak on ash <input type="checkbox"/>         | +\$50 |
| <b>EV</b> | walnut on ash <input type="checkbox"/>      | +\$50 |
| <b>UL</b> | natural maple <input type="checkbox"/>      | +\$50 |
| <b>UX</b> | walnut on cherry <input type="checkbox"/>   | +\$50 |

Top/Edge Finish: Opaque Formcoat®

*For painted Formcoat® top/edge (P)*

|           |                   |      |
|-----------|-------------------|------|
| <b>8Q</b> | folkstone grey    | +\$0 |
| <b>91</b> | white             | +\$0 |
| <b>CL</b> | cool grey neutral | +\$0 |
| <b>LU</b> | soft white        | +\$0 |
| <b>WL</b> | sandstone         | +\$0 |
| <b>WN</b> | warm grey neutral | +\$0 |

Step 7. Edge Finish

*For laminate top/thermoplastic edge (L)*

|            |                     |      |
|------------|---------------------|------|
| <b>76</b>  | light brown walnut  | +\$0 |
| <b>8Q</b>  | folkstone grey      | +\$0 |
| <b>91</b>  | white               | +\$0 |
| <b>98</b>  | studio white        | +\$0 |
| <b>CL</b>  | cool grey neutral   | +\$0 |
| <b>LA</b>  | light ash           | +\$0 |
| <b>LBA</b> | clear on ash        | +\$0 |
| <b>LBU</b> | medium matte walnut | +\$0 |
| <b>LBB</b> | oak on ash          | +\$0 |
| <b>LBC</b> | walnut on ash       | +\$0 |
| <b>LBD</b> | dark brown walnut   | +\$0 |
| <b>LBE</b> | medium red walnut   | +\$0 |
| <b>LBF</b> | neutral twill       | +\$0 |
| <b>LBG</b> | sarum twill         | +\$0 |
| <b>LBH</b> | earthen twill       | +\$0 |
| <b>LBJ</b> | graphite twill      | +\$0 |
| <b>LBK</b> | pewter mesh         | +\$0 |
| <b>LBL</b> | steel mesh          | +\$0 |
| <b>LBM</b> | crisp linen         | +\$0 |
| <b>LBN</b> | classic linen       | +\$0 |
| <b>LBP</b> | casual linen        | +\$0 |
| <b>LBQ</b> | white twill         | +\$0 |
| <b>WL</b>  | sandstone           | +\$0 |
| <b>WN</b>  | warm grey neutral   | +\$0 |
| <b>HF</b>  | inner tone light    | +\$0 |
| <b>HM</b>  | natural maple       | +\$0 |
| <b>HP</b>  | light anigre        | +\$0 |
| <b>HT</b>  | inner tone          | +\$0 |
| <b>HX</b>  | aged cherry         | +\$0 |
| <b>HY</b>  | walnut on cherry    | +\$0 |
| <b>LU</b>  | soft white          | +\$0 |

## D-Shaped Table *continued*

| Step 8. Leg Finish |   |        |
|--------------------|---|--------|
| <b>8Q</b>          | folkstone grey                          | +\$0   |
| <b>91</b>          | white                                   | +\$0   |
| <b>98</b>          | studio white <input type="checkbox"/> A | +\$0   |
| <b>BU</b>          | black umber                             | +\$0   |
| <b>CL</b>          | cool grey neutral                       | +\$0   |
| <b>G2</b>          | graphite satin                          | +\$0   |
| <b>HF</b>          | inner tone light                        | +\$0   |
| <b>LU</b>          | soft white                              | +\$0   |
| <b>MT</b>          | medium tone                             | +\$0   |
| <b>SG</b>          | slate grey                              | +\$0   |
| <b>WL</b>          | sandstone                               | +\$0   |
| <b>WN</b>          | warm grey neutral                       | +\$0   |
| <b>CN</b>          | metallic champagne                      | +\$20  |
| <b>EH</b>          | metallic bronze                         | +\$20  |
| <b>MS</b>          | metallic silver                         | +\$20  |
| <b>CD</b>          | polished aluminum                       | +\$110 |

| Step 9. Casters/Glides |         |      |
|------------------------|---------|------|
| <b>20</b>              | casters | +\$0 |
| <b>57</b>              | glides  | +\$0 |

# Soft Rectangle - Meeting Table

DT1FE.  
DT1FS.  
DT1FT.

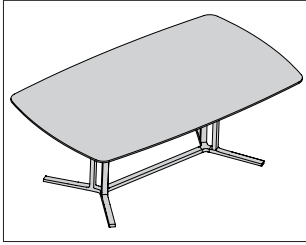

### Product Information

#### Description

This rectangular table comes in multiple edge styles and has a laminate top with thermoplastic edge, veneer top and edge, or painted top and edge. It has multiple leg/base options, and is available with casters or glides. The caster option has 2 locking and 2 non-locking casters. Glides have 1/2" leveling range. Shipped knocked down.

#### Notes

When specifying grommets (253, 254, 255), cutouts will be located in the center of table.

Cutouts available for all Connect™ power and data accessories (see Thrive® Portfolio). Cutouts will be located in the center, laterally and front to back.

For additional details on available edge options see Appendices.

For additional size, edge, and finish options, see Vary Easy Program in Appendices.

### Dimensions

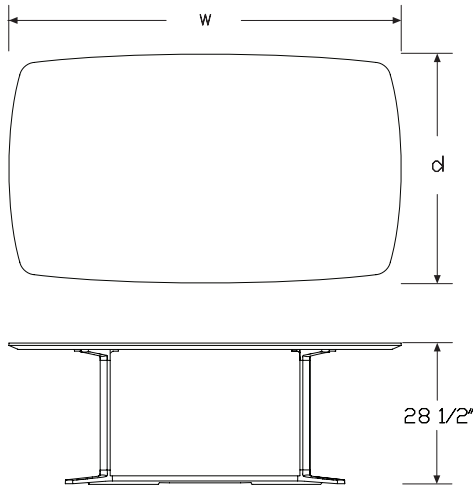

### Specification Information

#### Step 1.

**DT1F**

#### Step 2. Edge

- S.** squared-edge
- T.** thin-edge
- E.** eased-edge

#### Step 3. Depth

- 30** 30" deep
- 36** 36" deep
- 42** 42" deep

#### Step 4. Width

##### For 30" deep (30)

- 48** 48" wide
- 60** 60" wide

##### For 36" deep (36)

- 60** 60" wide
- 72** 72" wide

##### For 42" deep (42)

- 72** 72" wide
- 84** 84" wide

#### Step 5. Surface Material

##### For squared-edge (S.)

- L** laminate top/thermoplastic edge
- W** veneer top/veneer edge **A**
- P** painted Formcoat® top/edge

##### For thin-edge (T.)

- W** veneer top/veneer edge **A**
- P** painted Formcoat® top/edge

##### For eased-edge (E.)

- P** painted Formcoat® top/edge

# Soft Rectangle - Meeting Table

continued

Everywhere™ Standard-Height Tables

## Step 6. Leg/Base Type

For 48" wide (48) or 60" wide (60)

|          |                               |
|----------|-------------------------------|
| <b>P</b> | post leg                      |
| <b>G</b> | double 3-column base, spanner |
| <b>T</b> | T-leg                         |
| <b>A</b> | T-leg with height adjustment  |

For 72" wide (72) or 84" wide (84)

|          |                               |
|----------|-------------------------------|
| <b>P</b> | post leg                      |
| <b>E</b> | double 3-column base          |
| <b>G</b> | double 3-column base, spanner |

## Prices for Steps 1-6.

|                     | LP     | LE   | LG   | LT   | LA   | WP   |
|---------------------|--------|------|------|------|------|------|
| <b>DT1FS. 30 48</b> | \$1047 | —    | 1726 | 1476 | 1842 | 1554 |
| <b>60</b>           | \$1130 | —    | 1863 | 1613 | 2123 | 1681 |
| <b>36 60</b>        | \$1254 | —    | 2070 | 1821 | 1860 | 1877 |
| <b>72</b>           | \$1444 | 2452 | 2380 | —    | —    | 2169 |
| <b>42 84</b>        | \$1588 | 2695 | 2616 | —    | —    | 2392 |
| <b>72</b>           | \$1545 | 2623 | 2547 | —    | —    | 2325 |

|                     | WE     | WG     | WT   | WA   | PP   | PE   |
|---------------------|--------|--------|------|------|------|------|
| <b>DT1FS. 30 48</b> | —      | \$2606 | 2357 | 2349 | 1201 | —    |
| <b>60</b>           | —      | \$2821 | 2571 | 2710 | 1300 | —    |
| <b>36 60</b>        | —      | \$3142 | 2893 | 2431 | 1442 | —    |
| <b>72</b>           | \$3735 | 3625   | —    | —    | 1659 | 2819 |
| <b>42 84</b>        | \$4115 | 3994   | —    | —    | 1826 | 3099 |
| <b>72</b>           | \$4000 | 3883   | —    | —    | 1777 | 3015 |

|                     | PG     | PT   | PA   |
|---------------------|--------|------|------|
| <b>DT1FS. 30 48</b> | \$1984 | 1698 | 2120 |
| <b>60</b>           | \$2141 | 1857 | 2442 |
| <b>36 60</b>        | \$2380 | 2093 | 2138 |
| <b>72</b>           | \$2737 | —    | —    |
| <b>42 84</b>        | \$3008 | —    | —    |
| <b>72</b>           | \$2929 | —    | —    |

|                     | LP | LE | LG | LT | LA | WP     |
|---------------------|----|----|----|----|----|--------|
| <b>DT1FT. 30 48</b> | —  | —  | —  | —  | —  | \$1863 |
| <b>60</b>           | —  | —  | —  | —  | —  | \$2019 |
| <b>36 60</b>        | —  | —  | —  | —  | —  | \$2252 |
| <b>72</b>           | —  | —  | —  | —  | —  | \$2602 |
| <b>42 84</b>        | —  | —  | —  | —  | —  | \$2871 |
| <b>72</b>           | —  | —  | —  | —  | —  | \$2791 |

|                     | WE     | WG     | WT   | WA   | PP   | PE   |
|---------------------|--------|--------|------|------|------|------|
| <b>DT1FT. 30 48</b> | —      | \$3127 | 2828 | 2819 | 1280 | —    |
| <b>60</b>           | —      | \$3384 | 3085 | 3253 | 1384 | —    |
| <b>36 60</b>        | —      | \$3769 | 3470 | 2918 | 1536 | —    |
| <b>72</b>           | \$4481 | 4348   | —    | —    | 1768 | 3002 |
| <b>42 84</b>        | \$4937 | 4792   | —    | —    | 1945 | 3303 |
| <b>72</b>           | \$4800 | 4658   | —    | —    | 1892 | 3210 |

|                     | PG     | PT   | PA   |
|---------------------|--------|------|------|
| <b>DT1FT. 30 48</b> | \$2113 | 2711 | 3385 |
| <b>60</b>           | \$2282 | 2964 | 3898 |
| <b>36 60</b>        | \$2534 | 3343 | 3416 |
| <b>72</b>           | \$2915 | —    | —    |
| <b>42 84</b>        | \$3205 | —    | —    |
| <b>72</b>           | \$3119 | —    | —    |

|                     | WE | WG | WT | WA | PP     | PE   |
|---------------------|----|----|----|----|--------|------|
| <b>DT1FE. 30 48</b> | —  | —  | —  | —  | \$1280 | —    |
| <b>60</b>           | —  | —  | —  | —  | \$1384 | —    |
| <b>36 60</b>        | —  | —  | —  | —  | \$1536 | —    |
| <b>72</b>           | —  | —  | —  | —  | \$1768 | 3002 |
| <b>42 84</b>        | —  | —  | —  | —  | \$1945 | 3303 |
| <b>72</b>           | —  | —  | —  | —  | \$1892 | 3210 |

|                     | PG     | PT   | PA   |
|---------------------|--------|------|------|
| <b>DT1FE. 30 48</b> | \$2113 | 1808 | 2258 |
| <b>60</b>           | \$2282 | 1977 | 2599 |
| <b>36 60</b>        | \$2534 | 2229 | 2278 |
| <b>72</b>           | \$2915 | —    | —    |
| <b>42 84</b>        | \$3205 | —    | —    |
| <b>72</b>           | \$3119 | —    | —    |

## Step 7.

### Top Finish

For laminate top/thermoplastic edge (L)

|           |                    |      |
|-----------|--------------------|------|
| <b>28</b> | canyon             | +\$0 |
| <b>29</b> | misted             | +\$0 |
| <b>38</b> | twilight           | +\$0 |
| <b>39</b> | desert             | +\$0 |
| <b>76</b> | light brown walnut | +\$0 |
| <b>91</b> | white              | +\$0 |
| <b>98</b> | studio white       | +\$0 |
| <b>1X</b> | vanilla            | +\$0 |
| <b>2X</b> | wheat              | +\$0 |
| <b>3X</b> | celery             | +\$0 |
| <b>4X</b> | coriander          | +\$0 |

# Soft Rectangle - Meeting Table

continued

|            |                            |      |
|------------|----------------------------|------|
| <b>5X</b>  | chamomile                  | +\$0 |
| <b>6X</b>  | cinnamon                   | +\$0 |
| <b>7X</b>  | cardamom                   | +\$0 |
| <b>8X</b>  | kale                       | +\$0 |
| <b>8Q</b>  | folkstone grey             | +\$0 |
| <b>CL</b>  | cool grey neutral          | +\$0 |
| <b>HF</b>  | inner tone light           | +\$0 |
| <b>HM</b>  | natural maple              | +\$0 |
| <b>HP</b>  | light anigre               | +\$0 |
| <b>HT</b>  | inner tone                 | +\$0 |
| <b>HX</b>  | aged cherry                | +\$0 |
| <b>HY</b>  | walnut on cherry           | +\$0 |
| <b>J4</b>  | frosted light grey         | +\$0 |
| <b>J5</b>  | frosted inner tone light   | +\$0 |
| <b>J7</b>  | frosted medium tone        | +\$0 |
| <b>LA</b>  | light ash                  | +\$0 |
| <b>LBA</b> | clear on ash               | +\$0 |
| <b>LBU</b> | medium matte walnut        | +\$0 |
| <b>LBB</b> | oak on ash                 | +\$0 |
| <b>LBC</b> | walnut on ash              | +\$0 |
| <b>LBD</b> | dark brown walnut          | +\$0 |
| <b>LBE</b> | medium red walnut          | +\$0 |
| <b>LBF</b> | neutral twill              | +\$0 |
| <b>LBG</b> | sarum twill                | +\$0 |
| <b>LBH</b> | earthen twill              | +\$0 |
| <b>LBJ</b> | graphite twill             | +\$0 |
| <b>LBK</b> | pewter mesh                | +\$0 |
| <b>LBL</b> | steel mesh                 | +\$0 |
| <b>LBM</b> | crisp linen                | +\$0 |
| <b>LBN</b> | classic linen              | +\$0 |
| <b>LBP</b> | casual linen               | +\$0 |
| <b>LBQ</b> | white twill                | +\$0 |
| <b>LG</b>  | light grey (discontinuing) | +\$0 |
| <b>LM</b>  | mahogany                   | +\$0 |
| <b>LT</b>  | light tone                 | +\$0 |
| <b>LU</b>  | soft white                 | +\$0 |
| <b>MT</b>  | medium tone                | +\$0 |
| <b>OG</b>  | honey maple                | +\$0 |
| <b>WL</b>  | sandstone                  | +\$0 |
| <b>WN</b>  | warm grey neutral          | +\$0 |
| <b>X1</b>  | chalk white                | +\$0 |

---

## Top/Edge Finish

*For veneer top/veneer edge (W)*

|           |   |       |
|-----------|---|-------|
| <b>2U</b> | light brown walnut <input type="checkbox"/> A | +\$85 |
| <b>40</b> | dark brown walnut <input type="checkbox"/> A  | +\$85 |
| <b>ED</b> | aged cherry <input type="checkbox"/> A        | +\$85 |
| <b>EK</b> | medium red walnut <input type="checkbox"/> A  | +\$85 |
| <b>ET</b> | clear on ash <input type="checkbox"/> A       | +\$85 |
| <b>EU</b> | oak on ash <input type="checkbox"/> A         | +\$85 |
| <b>EV</b> | walnut on ash <input type="checkbox"/> A      | +\$85 |
| <b>UL</b> | natural maple <input type="checkbox"/> A      | +\$85 |
| <b>UX</b> | walnut on cherry <input type="checkbox"/> A   | +\$85 |

---

## Top/Edge Finish: Opaque Formcoat®

*For painted Formcoat® top/edge (P)*

|           |                   |      |
|-----------|-------------------|------|
| <b>8Q</b> | folkstone grey    | +\$0 |
| <b>91</b> | white             | +\$0 |
| <b>CL</b> | cool grey neutral | +\$0 |
| <b>LU</b> | soft white        | +\$0 |
| <b>WL</b> | sandstone         | +\$0 |
| <b>WN</b> | warm grey neutral | +\$0 |

Everywhere™ Standard-Height Tables

# Soft Rectangle - Meeting Table

continued

Everywhere™ Standard-Height Tables

| Step 8. Edge Finish                            |                     |      |
|--|---------------------|------|
| <i>For laminate top/thermoplastic edge (L)</i> |                     |      |
| <b>76</b>                                      | light brown walnut  | +\$0 |
| <b>8Q</b>                                      | folkstone grey      | +\$0 |
| <b>91</b>                                      | white               | +\$0 |
| <b>98</b>                                      | studio white        | +\$0 |
| <b>CL</b>                                      | cool grey neutral   | +\$0 |
| <b>LA</b>                                      | light ash           | +\$0 |
| <b>LBA</b>                                     | clear on ash        | +\$0 |
| <b>LBU</b>                                     | medium matte walnut | +\$0 |
| <b>LBB</b>                                     | oak on ash          | +\$0 |
| <b>LBC</b>                                     | walnut on ash       | +\$0 |
| <b>LBD</b>                                     | dark brown walnut   | +\$0 |
| <b>LBE</b>                                     | medium red walnut   | +\$0 |
| <b>LBF</b>                                     | neutral twill       | +\$0 |
| <b>LBG</b>                                     | sarum twill         | +\$0 |
| <b>LBH</b>                                     | earthen twill       | +\$0 |
| <b>LBJ</b>                                     | graphite twill      | +\$0 |
| <b>LBK</b>                                     | pewter mesh         | +\$0 |
| <b>LBL</b>                                     | steel mesh          | +\$0 |
| <b>LBM</b>                                     | crisp linen         | +\$0 |
| <b>LBN</b>                                     | classic linen       | +\$0 |
| <b>LBP</b>                                     | casual linen        | +\$0 |
| <b>LBQ</b>                                     | white twill         | +\$0 |
| <b>WL</b>                                      | sandstone           | +\$0 |
| <b>WN</b>                                      | warm grey neutral   | +\$0 |
| <b>HF</b>                                      | inner tone light    | +\$0 |
| <b>HM</b>                                      | natural maple       | +\$0 |
| <b>HP</b>                                      | light anigre        | +\$0 |
| <b>HT</b>                                      | inner tone          | +\$0 |
| <b>HX</b>                                      | aged cherry         | +\$0 |
| <b>HY</b>                                      | walnut on cherry    | +\$0 |
| <b>LU</b>                                      | soft white          | +\$0 |
| <b>X1</b>                                      | chalk white         | +\$0 |

| Step 9. Leg/Base Finish |  |        |
|-------------------------|--|--------|
| <b>8Q</b>               | folkstone grey   | +\$0   |
| <b>91</b>               | white  | +\$0   |
| <b>98</b>               | studio white <span style="border: 1px solid black; padding: 0 2px;">A</span> | +\$0   |
| <b>BU</b>               | black umber  | +\$0   |
| <b>CL</b>               | cool grey neutral  | +\$0   |
| <b>G2</b>               | graphite satin   | +\$0   |
| <b>HF</b>               | inner tone light   | +\$0   |
| <b>LU</b>               | soft white   | +\$0   |
| <b>MT</b>               | medium tone  | +\$0   |
| <b>SG</b>               | slate grey   | +\$0   |
| <b>WL</b>               | sandstone  | +\$0   |
| <b>WN</b>               | warm grey neutral  | +\$0   |
| <b>CN</b>               | metallic champagne   | +\$20  |
| <b>EH</b>               | metallic bronze  | +\$20  |
| <b>MS</b>               | metallic silver  | +\$20  |
| <b>CD</b>               | polished aluminum  | +\$110 |

| Step 10. Casters/Glides |         |      |
|-------------------------|---------|------|
| <b>20</b>               | casters | +\$0 |
| <b>57</b>               | glides  | +\$0 |

| Step 11. Grommets |                                      |       |
|-------------------|--------------------------------------|-------|
| <b>NTG</b>        | no grommet                           | +\$0  |
| <b>253</b>        | cutout for Y1420. or Y1425. - 3 port | +\$27 |
| <b>254</b>        | cutout for Y1420. or Y1425. - 5 port | +\$27 |
| <b>255</b>        | cutout for Y1420. or Y1425. - 6 port | +\$27 |



# Video Oval - Meeting Table

DT1GE.  
DT1GS.  
DT1GT.

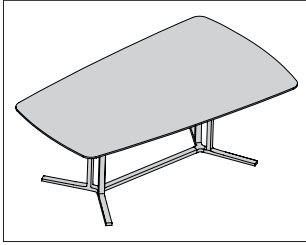

### Product Information

#### Description

This oval table comes in multiple edge styles and has a laminate top with thermoplastic edge, veneer top and edge, or painted top and edge. It has multiple leg/base options, and is available with casters or glides. The caster option has 2 locking and 2 non-locking casters. Glides have 1/2" leveling range. Shipped knocked down.

#### Notes

When specifying grommets (253, 254, 255), cutouts will be located in the center of table.

Cutouts available for all Connect™ power and data accessories (see Thrive® Portfolio). Cutouts will be located in the center, laterally and front to back.

For optimum viewing, video camera should be placed 42" from large end of table.

For additional details on available edge options see Appendices.

For additional size, edge, and finish options, see Vary Easy Program in Appendices.

### Dimensions

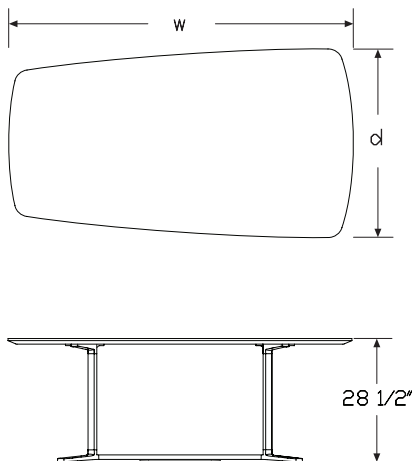

### Specification Information

#### Step 1.

**DT1G**

#### Step 2. Edge

- S.** squared-edge
- T.** thin-edge
- E.** eased-edge

#### Step 3. Depth

**42** 42" deep

#### Step 4. Width

**72** 72" wide  
**84** 84" wide

#### Step 5. Surface Material

##### For squared-edge (S.)

- L** laminate top/thermoplastic edge
- W** veneer top/veneer edge **A**
- P** painted Formcoat® top/edge

##### For thin-edge (T.)

- W** veneer top/veneer edge **A**
- P** painted Formcoat® top/edge

##### For eased-edge (E.)

- P** painted Formcoat® top/edge

#### Step 6. Leg/Base Type

- E** double 3-column base
- G** double 3-column base, spanner

#### Prices for Steps 1-6.

|                     | LE     | LG   | WE     | WG   | PE     | PG   |
|---------------------|--------|------|--------|------|--------|------|
| <b>DT1GS. 42 72</b> | \$2623 | 2547 | 4000   | 3883 | 3015   | 2929 |
| <b>84</b>           | \$2695 | 2616 | 4115   | 3994 | 3099   | 3008 |
| <b>DT1GT. 42 72</b> | —      | —    | \$4800 | 4658 | 3694   | 3588 |
| <b>84</b>           | —      | —    | \$4937 | 4792 | 3796   | 3685 |
| <b>DT1GE. 42 72</b> | —      | —    | —      | —    | \$3210 | 3119 |
| <b>84</b>           | —      | —    | —      | —    | \$3303 | 3205 |

Step 7.

Top Finish

*For laminate top/thermoplastic edge (L)*

|            |                          |      |
|------------|--------------------------|------|
| <b>28</b>  | canyon                   | +\$0 |
| <b>29</b>  | misted                   | +\$0 |
| <b>38</b>  | twilight                 | +\$0 |
| <b>39</b>  | desert                   | +\$0 |
| <b>76</b>  | light brown walnut       | +\$0 |
| <b>91</b>  | white                    | +\$0 |
| <b>98</b>  | studio white             | +\$0 |
| <b>1X</b>  | vanilla                  | +\$0 |
| <b>2X</b>  | wheat                    | +\$0 |
| <b>3X</b>  | celery                   | +\$0 |
| <b>4X</b>  | coriander                | +\$0 |
| <b>5X</b>  | chamomile                | +\$0 |
| <b>6X</b>  | cinnamon                 | +\$0 |
| <b>7X</b>  | cardamom                 | +\$0 |
| <b>8X</b>  | kale                     | +\$0 |
| <b>8Q</b>  | folkstone grey           | +\$0 |
| <b>CL</b>  | cool grey neutral        | +\$0 |
| <b>HF</b>  | inner tone light         | +\$0 |
| <b>HM</b>  | natural maple            | +\$0 |
| <b>HP</b>  | light anigre             | +\$0 |
| <b>HT</b>  | inner tone               | +\$0 |
| <b>HX</b>  | aged cherry              | +\$0 |
| <b>HY</b>  | walnut on cherry         | +\$0 |
| <b>J4</b>  | frosted light grey       | +\$0 |
| <b>J5</b>  | frosted inner tone light | +\$0 |
| <b>J7</b>  | frosted medium tone      | +\$0 |
| <b>LA</b>  | light ash                | +\$0 |
| <b>LBA</b> | clear on ash             | +\$0 |
| <b>LBU</b> | medium matte walnut      | +\$0 |
| <b>LBB</b> | oak on ash               | +\$0 |
| <b>LBC</b> | walnut on ash            | +\$0 |
| <b>LBD</b> | dark brown walnut        | +\$0 |
| <b>LBE</b> | medium red walnut        | +\$0 |
| <b>LBF</b> | neutral twill            | +\$0 |
| <b>LBG</b> | sarum twill              | +\$0 |
| <b>LBH</b> | earthen twill            | +\$0 |
| <b>LBJ</b> | graphite twill           | +\$0 |
| <b>LBK</b> | pewter mesh              | +\$0 |
| <b>LBL</b> | steel mesh               | +\$0 |
| <b>LBM</b> | crisp linen              | +\$0 |
| <b>LBN</b> | classic linen            | +\$0 |
| <b>LBP</b> | casual linen             | +\$0 |
| <b>LBQ</b> | white twill              | +\$0 |

|           |                            |      |
|-----------|----------------------------|------|
| <b>LG</b> | light grey (discontinuing) | +\$0 |
| <b>LM</b> | mahogany                   | +\$0 |
| <b>LT</b> | light tone                 | +\$0 |
| <b>LU</b> | soft white                 | +\$0 |
| <b>MT</b> | medium tone                | +\$0 |
| <b>OG</b> | honey maple                | +\$0 |
| <b>WL</b> | sandstone                  | +\$0 |
| <b>WN</b> | warm grey neutral          | +\$0 |
| <b>X1</b> | chalk white                | +\$0 |

Top/Edge Finish

*For veneer top/veneer edge (W)*

|           |   |       |
|-----------|---|-------|
| <b>2U</b> | light brown walnut <input type="checkbox"/> A | +\$85 |
| <b>40</b> | dark brown walnut <input type="checkbox"/> A  | +\$85 |
| <b>ED</b> | aged cherry <input type="checkbox"/> A        | +\$85 |
| <b>EK</b> | medium red walnut <input type="checkbox"/> A  | +\$85 |
| <b>ET</b> | clear on ash <input type="checkbox"/> A       | +\$85 |
| <b>EU</b> | oak on ash <input type="checkbox"/> A         | +\$85 |
| <b>EV</b> | walnut on ash <input type="checkbox"/> A      | +\$85 |
| <b>UL</b> | natural maple <input type="checkbox"/> A      | +\$85 |
| <b>UX</b> | walnut on cherry <input type="checkbox"/> A   | +\$85 |

Top/Edge Finish: Opaque Formcoat®

*For painted Formcoat® top/edge (P)*

|           |                   |      |
|-----------|-------------------|------|
| <b>8Q</b> | folkstone grey    | +\$0 |
| <b>91</b> | white             | +\$0 |
| <b>CL</b> | cool grey neutral | +\$0 |
| <b>LU</b> | soft white        | +\$0 |
| <b>WL</b> | sandstone         | +\$0 |
| <b>WN</b> | warm grey neutral | +\$0 |

| Step 8. Edge Finish                            |                     |      |
|--|---------------------|------|
| <i>For laminate top/thermoplastic edge (L)</i> |                     |      |
| <b>76</b>                                      | light brown walnut  | +\$0 |
| <b>8Q</b>                                      | folkstone grey      | +\$0 |
| <b>91</b>                                      | white               | +\$0 |
| <b>98</b>                                      | studio white        | +\$0 |
| <b>CL</b>                                      | cool grey neutral   | +\$0 |
| <b>LA</b>                                      | light ash           | +\$0 |
| <b>LBA</b>                                     | clear on ash        | +\$0 |
| <b>LBU</b>                                     | medium matte walnut | +\$0 |
| <b>LBB</b>                                     | oak on ash          | +\$0 |
| <b>LBC</b>                                     | walnut on ash       | +\$0 |
| <b>LBD</b>                                     | dark brown walnut   | +\$0 |
| <b>LBE</b>                                     | medium red walnut   | +\$0 |
| <b>LBF</b>                                     | neutral twill       | +\$0 |
| <b>LBG</b>                                     | sarum twill         | +\$0 |
| <b>LBH</b>                                     | earthen twill       | +\$0 |
| <b>LBJ</b>                                     | graphite twill      | +\$0 |
| <b>LBK</b>                                     | pewter mesh         | +\$0 |
| <b>LBL</b>                                     | steel mesh          | +\$0 |
| <b>LBM</b>                                     | crisp linen         | +\$0 |
| <b>LBN</b>                                     | classic linen       | +\$0 |
| <b>LBP</b>                                     | casual linen        | +\$0 |
| <b>LBQ</b>                                     | white twill         | +\$0 |
| <b>WL</b>                                      | sandstone           | +\$0 |
| <b>WN</b>                                      | warm grey neutral   | +\$0 |
| <b>HF</b>                                      | inner tone light    | +\$0 |
| <b>HM</b>                                      | natural maple       | +\$0 |
| <b>HP</b>                                      | light anigre        | +\$0 |
| <b>HT</b>                                      | inner tone          | +\$0 |
| <b>HX</b>                                      | aged cherry         | +\$0 |
| <b>HY</b>                                      | walnut on cherry    | +\$0 |
| <b>LU</b>                                      | soft white          | +\$0 |

| Step 9. Leg/Base Finish |  |        |
|-------------------------|--|--------|
| <b>8Q</b>               | folkstone grey   | +\$0   |
| <b>91</b>               | white  | +\$0   |
| <b>98</b>               | studio white <span style="border: 1px solid black; padding: 0 2px;">A</span> | +\$0   |
| <b>BU</b>               | black umber  | +\$0   |
| <b>CL</b>               | cool grey neutral  | +\$0   |
| <b>G2</b>               | graphite satin   | +\$0   |
| <b>HF</b>               | inner tone light   | +\$0   |
| <b>LU</b>               | soft white   | +\$0   |
| <b>MT</b>               | medium tone  | +\$0   |
| <b>SG</b>               | slate grey   | +\$0   |
| <b>WL</b>               | sandstone  | +\$0   |
| <b>WN</b>               | warm grey neutral  | +\$0   |
| <b>CN</b>               | metallic champagne   | +\$20  |
| <b>EH</b>               | metallic bronze  | +\$20  |
| <b>MS</b>               | metallic silver  | +\$20  |
| <b>CD</b>               | polished aluminum  | +\$110 |

| Step 10. Casters/Glides |         |      |
|-------------------------|---------|------|
| <b>20</b>               | casters | +\$0 |
| <b>57</b>               | glides  | +\$0 |

| Step 11. Grommets |                                      |       |
|-------------------|--------------------------------------|-------|
| <b>NTG</b>        | no grommet                           | +\$0  |
| <b>253</b>        | cutout for Y1420. or Y1425. - 3 port | +\$27 |
| <b>254</b>        | cutout for Y1420. or Y1425. - 5 port | +\$27 |
| <b>255</b>        | cutout for Y1420. or Y1425. - 6 port | +\$27 |

## Concave Rectangle

DT1HE.  
DT1HS.  
DT1HT.

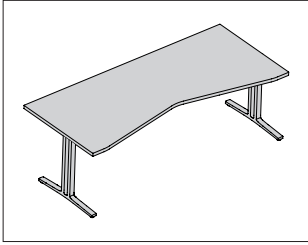

### Product Information

#### Description

This rectangular table comes in multiple edge styles and has a laminate top with thermoplastic edge, veneer top and edge, or painted top and edge. It has multiple leg options, and is available with casters or glides. The caster option has 2 locking and 2 non-locking casters. Glides have 1/2" leveling range. Shipped knocked down. Height-adjustable legs have a 5" range in 1" increments.

#### Notes

When specifying grommets (253, 254, 255), cutouts will be located in the center of table.

Cutouts available for all Connect™ power and data accessories (see Thrive® Portfolio). Cutouts will be located in the center, laterally, and approximately 3" from the rear edge of surface.

Reinforcement channels are used under table tops 54" and wider. They will be located along the center line for 18" deep and 24" deep surfaces, and 19" from the front edge for 30" deep surfaces.

For additional details on available edge options see Appendices.

For additional size, edge, finish, and cable management options, see Vary Easy Program in Appendices.

UL listed when used with Connect single circuit electrical product (Y137x.) with post leg (P), T-leg (T) and C-leg (C) options.

### Dimensions

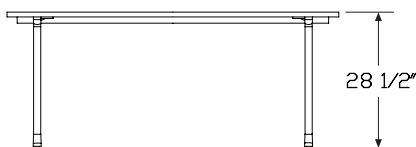
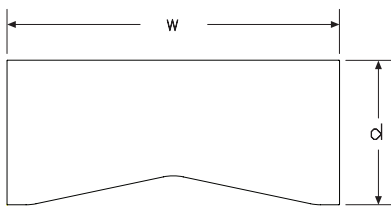

### Specification Information

#### Step 1.

**DT1H**

#### Step 2. Edge

- S.** squared-edge
- T.** thin-edge
- E.** eased-edge

#### Step 3. Depth

- 30** 30" deep
- 36** 36" deep

#### Step 4. Width

- 60** 60" wide
- 66** 66" wide
- 72** 72" wide

#### Step 5. Surface Material

##### For squared-edge (S.)

- L** laminate top/thermoplastic edge
- W** veneer top/veneer edge **A**
- P** painted Formcoat® top/edge

##### For thin-edge (T.)

- W** veneer top/veneer edge **A**
- P** painted Formcoat® top/edge

##### For eased-edge (E.)

- P** painted Formcoat® top/edge

#### Step 6. Leg Type

##### For 30" deep (30)

- P** post leg
- T** T-leg
- A** T-leg with height adjustment
- C** C-leg
- D** D-leg

##### For 36" deep (36)

- P** post leg
- T** T-leg
- A** T-leg with height adjustment

Concave Rectangle *continued*

| Prices for Steps 1-6. |        |      |        |      |      |        |
|-----------------------|--------|------|--------|------|------|--------|
|                       | LP     | LT   | LA     | LC   | LD   | WP     |
| <b>DT1HS. 30 60</b>   | \$1191 | 1547 | 1932   | 1547 | 1932 | 1471   |
| <b>66</b>             | \$1276 | 1658 | 2071   | 1658 | 2071 | 1584   |
| <b>72</b>             | \$1361 | 1769 | 2211   | 1769 | 2211 | 1696   |
| <b>36 60</b>          | \$1262 | 1602 | 1948   | —    | —    | 1527   |
| <b>66</b>             | \$1329 | 1690 | 2131   | —    | —    | 1639   |
| <b>72</b>             | \$1396 | 1777 | 2313   | —    | —    | 1750   |
|                       | WT     | WA   | WC     | WD   | PP   | PT     |
| <b>DT1HS. 30 60</b>   | \$1935 | 2436 | 1935   | 2436 | 1370 | 1778   |
| <b>66</b>             | \$2080 | 2618 | 2080   | 2618 | 1467 | 1906   |
| <b>72</b>             | \$2224 | 2799 | 2224   | 2799 | 1566 | 2035   |
| <b>36 60</b>          | \$1989 | 2493 | —      | —    | 1452 | 1842   |
| <b>66</b>             | \$2135 | 2673 | —      | —    | 1529 | 1943   |
| <b>72</b>             | \$2279 | 2855 | —      | —    | 1605 | 2042   |
|                       |        |      | PA     | PC   | PD   |        |
| <b>DT1HS. 30 60</b>   |        |      | \$2221 | 1778 | 2221 |        |
| <b>66</b>             |        |      | \$2382 | 1906 | 2382 |        |
| <b>72</b>             |        |      | \$2542 | 2035 | 2542 |        |
| <b>36 60</b>          |        |      | \$2240 | —    | —    |        |
| <b>66</b>             |        |      | \$2450 | —    | —    |        |
| <b>72</b>             |        |      | \$2661 | —    | —    |        |
|                       | LP     | LT   | LA     | LC   | LD   | WP     |
| <b>DT1HT. 30 60</b>   | —      | —    | —      | —    | —    | \$1765 |
| <b>66</b>             | —      | —    | —      | —    | —    | \$1899 |
| <b>72</b>             | —      | —    | —      | —    | —    | \$2035 |
| <b>36 60</b>          | —      | —    | —      | —    | —    | \$1832 |
| <b>66</b>             | —      | —    | —      | —    | —    | \$1966 |
| <b>72</b>             | —      | —    | —      | —    | —    | \$2101 |
|                       | WT     | WA   | WC     | WD   | PP   | PT     |
| <b>DT1HT. 30 60</b>   | \$2320 | 2925 | 2320   | 2925 | 1458 | 1894   |
| <b>66</b>             | \$2495 | 3142 | 2495   | 3142 | 1563 | 2030   |
| <b>72</b>             | \$2669 | 3358 | 2669   | 3358 | 1668 | 2167   |
| <b>36 60</b>          | \$2387 | 2991 | —      | —    | 1545 | 1963   |
| <b>66</b>             | \$2561 | 3207 | —      | —    | 1629 | 2069   |
| <b>72</b>             | \$2736 | 3425 | —      | —    | 1710 | 2175   |
|                       |        |      | PA     | PC   | PD   |        |
| <b>DT1HT. 30 60</b>   |        |      | \$2367 | 1894 | 2367 |        |
| <b>66</b>             |        |      | \$2536 | 2030 | 2536 |        |
| <b>72</b>             |        |      | \$2707 | 2167 | 2707 |        |

| <b>36 60</b>        | \$2386 | —      | —    |      |        |      |
|---------------------|--------|--------|------|------|--------|------|
| <b>66</b>           | \$2608 | —      | —    |      |        |      |
| <b>72</b>           | \$2833 | —      | —    |      |        |      |
|                     | WT     | WA     | WC   | WD   | PP     | PT   |
| <b>DT1HE. 30 60</b> | —      | —      | —    | —    | \$1458 | 1894 |
| <b>66</b>           | —      | —      | —    | —    | \$1563 | 2030 |
| <b>72</b>           | —      | —      | —    | —    | \$1668 | 2167 |
| <b>36 60</b>        | —      | —      | —    | —    | \$1545 | 1963 |
| <b>66</b>           | —      | —      | —    | —    | \$1629 | 2069 |
| <b>72</b>           | —      | —      | —    | —    | \$1710 | 2175 |
|                     |        | PA     | PC   | PD   |        |      |
| <b>DT1HE. 30 60</b> |        | \$2367 | 1894 | 2367 |        |      |
| <b>66</b>           |        | \$2536 | 2030 | 2536 |        |      |
| <b>72</b>           |        | \$2707 | 2167 | 2707 |        |      |
| <b>36 60</b>        |        | \$2386 | —    | —    |        |      |
| <b>66</b>           |        | \$2608 | —    | —    |        |      |
| <b>72</b>           |        | \$2833 | —    | —    |        |      |

| Step 7.  |                    |      |
|--|--------------------|------|
| Top Finish                                     |                    |      |
| <i>For laminate top/thermoplastic edge (L)</i> |                    |      |
| <b>28</b>                                      | canyon             | +\$0 |
| <b>29</b>                                      | misted             | +\$0 |
| <b>38</b>                                      | twilight           | +\$0 |
| <b>39</b>                                      | desert             | +\$0 |
| <b>76</b>                                      | light brown walnut | +\$0 |
| <b>91</b>                                      | white              | +\$0 |
| <b>98</b>                                      | studio white       | +\$0 |
| <b>1X</b>                                      | vanilla            | +\$0 |
| <b>2X</b>                                      | wheat              | +\$0 |
| <b>3X</b>                                      | celery             | +\$0 |
| <b>4X</b>                                      | coriander          | +\$0 |
| <b>5X</b>                                      | chamomile          | +\$0 |
| <b>6X</b>                                      | cinnamon           | +\$0 |
| <b>7X</b>                                      | cardamom           | +\$0 |
| <b>8X</b>                                      | kale               | +\$0 |
| <b>8Q</b>                                      | folkstone grey     | +\$0 |
| <b>CL</b>                                      | cool grey neutral  | +\$0 |
| <b>HF</b>                                      | inner tone light   | +\$0 |
| <b>HM</b>                                      | natural maple      | +\$0 |
| <b>HP</b>                                      | light anigre       | +\$0 |
| <b>HT</b>                                      | inner tone         | +\$0 |
| <b>HX</b>                                      | aged cherry        | +\$0 |
| <b>HY</b>                                      | walnut on cherry   | +\$0 |

Everywhere™ Standard-Height Tables

# Concave Rectangle *continued*

Everywhere™ Standard-Height Tables

|            |                            |      |
|------------|----------------------------|------|
| <b>J4</b>  | frosted light grey         | +\$0 |
| <b>J5</b>  | frosted inner tone light   | +\$0 |
| <b>J7</b>  | frosted medium tone        | +\$0 |
| <b>LA</b>  | light ash                  | +\$0 |
| <b>LBA</b> | clear on ash               | +\$0 |
| <b>LBU</b> | medium matte walnut        | +\$0 |
| <b>LBB</b> | oak on ash                 | +\$0 |
| <b>LBC</b> | walnut on ash              | +\$0 |
| <b>LBD</b> | dark brown walnut          | +\$0 |
| <b>LBE</b> | medium red walnut          | +\$0 |
| <b>LBF</b> | neutral twill              | +\$0 |
| <b>LBG</b> | sarum twill                | +\$0 |
| <b>LBH</b> | earthen twill              | +\$0 |
| <b>LBJ</b> | graphite twill             | +\$0 |
| <b>LBK</b> | pewter mesh                | +\$0 |
| <b>LBL</b> | steel mesh                 | +\$0 |
| <b>LBM</b> | crisp linen                | +\$0 |
| <b>LBN</b> | classic linen              | +\$0 |
| <b>LBP</b> | casual linen               | +\$0 |
| <b>LBQ</b> | white twill                | +\$0 |
| <b>LG</b>  | light grey (discontinuing) | +\$0 |
| <b>LM</b>  | mahogany                   | +\$0 |
| <b>LT</b>  | light tone                 | +\$0 |
| <b>LU</b>  | soft white                 | +\$0 |
| <b>MT</b>  | medium tone                | +\$0 |
| <b>OG</b>  | honey maple                | +\$0 |
| <b>WL</b>  | sandstone                  | +\$0 |
| <b>WN</b>  | warm grey neutral          | +\$0 |
| <b>X1</b>  | chalk white                | +\$0 |

Top/Edge Finish: Wood Veneer

*For veneer top/veneer edge (W)*

|           |  |       |
|-----------|--|-------|
| <b>2U</b> | light brown walnut <span style="border: 1px solid black; padding: 0 2px;">A</span> | +\$85 |
| <b>40</b> | dark brown walnut <span style="border: 1px solid black; padding: 0 2px;">A</span>  | +\$85 |
| <b>ED</b> | aged cherry <span style="border: 1px solid black; padding: 0 2px;">A</span>        | +\$85 |
| <b>EK</b> | medium red walnut <span style="border: 1px solid black; padding: 0 2px;">A</span>  | +\$85 |
| <b>ET</b> | clear on ash   | +\$85 |
| <b>EU</b> | oak on ash   | +\$85 |
| <b>EV</b> | walnut on ash  | +\$85 |
| <b>UL</b> | natural maple <span style="border: 1px solid black; padding: 0 2px;">A</span>      | +\$85 |
| <b>UX</b> | walnut on cherry <span style="border: 1px solid black; padding: 0 2px;">A</span>   | +\$85 |

Top/Edge Finish: Opaque Formcoat®

*For painted Formcoat® top/edge (P)*

|           |                   |      |
|-----------|-------------------|------|
| <b>8Q</b> | folkstone grey    | +\$0 |
| <b>91</b> | white             | +\$0 |
| <b>CL</b> | cool grey neutral | +\$0 |
| <b>LU</b> | soft white        | +\$0 |
| <b>WL</b> | sandstone         | +\$0 |
| <b>WN</b> | warm grey neutral | +\$0 |

Step 8. Edge Finish

*For laminate top/thermoplastic edge (L)*

|            |                     |      |
|------------|---------------------|------|
| <b>76</b>  | light brown walnut  | +\$0 |
| <b>8Q</b>  | folkstone grey      | +\$0 |
| <b>91</b>  | white               | +\$0 |
| <b>98</b>  | studio white        | +\$0 |
| <b>CL</b>  | cool grey neutral   | +\$0 |
| <b>LA</b>  | light ash           | +\$0 |
| <b>LBA</b> | clear on ash        | +\$0 |
| <b>LBU</b> | medium matte walnut | +\$0 |
| <b>LBB</b> | oak on ash          | +\$0 |
| <b>LBC</b> | walnut on ash       | +\$0 |
| <b>LBD</b> | dark brown walnut   | +\$0 |
| <b>LBE</b> | medium red walnut   | +\$0 |
| <b>LBF</b> | neutral twill       | +\$0 |
| <b>LBG</b> | sarum twill         | +\$0 |
| <b>LBH</b> | earthen twill       | +\$0 |
| <b>LBJ</b> | graphite twill      | +\$0 |
| <b>LBK</b> | pewter mesh         | +\$0 |
| <b>LBL</b> | steel mesh          | +\$0 |
| <b>LBM</b> | crisp linen         | +\$0 |
| <b>LBN</b> | classic linen       | +\$0 |
| <b>LBP</b> | casual linen        | +\$0 |
| <b>LBQ</b> | white twill         | +\$0 |
| <b>WL</b>  | sandstone           | +\$0 |
| <b>WN</b>  | warm grey neutral   | +\$0 |
| <b>HF</b>  | inner tone light    | +\$0 |
| <b>HM</b>  | natural maple       | +\$0 |
| <b>HP</b>  | light anigre        | +\$0 |
| <b>HT</b>  | inner tone          | +\$0 |
| <b>HX</b>  | aged cherry         | +\$0 |
| <b>HY</b>  | walnut on cherry    | +\$0 |
| <b>LU</b>  | soft white          | +\$0 |

## Concave Rectangle *continued*

| Step 9. Leg Finish      |   |        |
|-------------------------|---|--------|
| <b>8Q</b>               | folkstone grey                          | +\$0   |
| <b>91</b>               | white                                   | +\$0   |
| <b>98</b>               | studio white <input type="checkbox"/> A | +\$0   |
| <b>BU</b>               | black umber                             | +\$0   |
| <b>CL</b>               | cool grey neutral                       | +\$0   |
| <b>G2</b>               | graphite satin                          | +\$0   |
| <b>HF</b>               | inner tone light                        | +\$0   |
| <b>LU</b>               | soft white                              | +\$0   |
| <b>MT</b>               | medium tone                             | +\$0   |
| <b>SG</b>               | slate grey                              | +\$0   |
| <b>WL</b>               | sandstone                               | +\$0   |
| <b>WN</b>               | warm grey neutral                       | +\$0   |
| <b>CN</b>               | metallic champagne                      | +\$20  |
| <b>EH</b>               | metallic bronze                         | +\$20  |
| <b>MS</b>               | metallic silver                         | +\$20  |
| <b>CD</b>               | polished aluminum                       | +\$110 |
| Step 10. Casters/Glides |   |        |
| <b>20</b>               | casters                                 | +\$0   |
| <b>57</b>               | glides                                  | +\$0   |
| Step 11. Grommets       |   |        |
| <b>NTG</b>              | no grommet                              | +\$0   |
| <b>253</b>              | cutout for Y1420. or Y1425. - 3 port    | +\$27  |
| <b>254</b>              | cutout for Y1420. or Y1425. - 5 port    | +\$27  |
| <b>255</b>              | cutout for Y1420. or Y1425. - 6 port    | +\$27  |

# Soft Square Table

DT1JE.  
DT1JS.  
DT1JT.

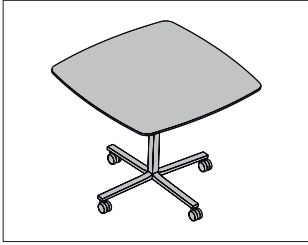

Everywhere™ Standard-Height Tables

### Product Information

#### Description

This square table comes in multiple edge styles and has a laminate top with thermoplastic edge, veneer top and edge, or painted top and edge. It has multiple leg/base options, and is available with casters or glides. The caster option has 2 locking and 2 non-locking casters. Glides have 1/2" leveling range. Shipped knocked down.

#### Notes

48" tops available only with post leg option for optimum stability.

For additional details on available edge options see Appendices.

For additional size, edge, and finish options, see Vary Easy Program in Appendices.

UL listed when used with Connect™ single circuit electrical product (Y137x.) with post leg (P) option.

#### Dimensions

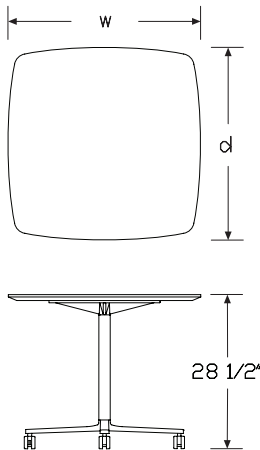

### Specification Information

#### Step 1.

**DT1J**

#### Step 2. Edge

- S.** squared-edge
- T.** thin-edge
- E.** eased-edge

#### Step 3. Depth/Width

- 3030** 30" deep x 30" wide
- 3636** 36" deep x 36" wide
- 4242** 42" deep x 42" wide
- 4848** 48" deep x 48" wide

#### Step 4. Surface Material

##### For squared-edge (S.)

- L** laminate top/thermoplastic edge
- W** veneer top/veneer edge A
- P** painted Formcoat® top/edge

##### For thin-edge (T.)

- W** veneer top/veneer edge A
- P** painted Formcoat® top/edge

##### For eased-edge (E.)

- P** painted Formcoat® top/edge

#### Step 5. Leg/Base Type

##### For 30" deep x 30" wide (3030) or 36" deep x 36" wide (3636)

- P** post leg
- S** single-column base A

##### For 42" deep x 42" wide (4242)

- P** post leg

##### For 48" deep x 48" wide (4848)

- P** post leg

#### Prices for Steps 1-5.

|                    |          | P      | S    |
|--------------------|----------|--------|------|
| <b>DT1JS. 3030</b> | <b>L</b> | \$798  | 880  |
|                    | <b>W</b> | \$1009 | 1120 |
|                    | <b>P</b> | \$916  | 1013 |



Soft Square Table *continued*

|                      |          |          |
|----------------------|----------|----------|
| <b>3636 L</b>        | \$956    | 1056     |
| <b>W</b>             | \$1224   | 1357     |
| <b>P</b>             | \$1100   | 1214     |
| <b>4242 L</b>        | \$1098   | —        |
| <b>W</b>             | \$1416   | —        |
| <b>P</b>             | \$1264   | —        |
| <b>4848 L</b>        | \$1231   | —        |
| <b>W</b>             | \$1659   | —        |
| <b>P</b>             | \$1416   | —        |
|                      | <b>P</b> | <b>S</b> |
| <b>DT1JT. 3030 W</b> | \$1209   | 1344     |
| <b>P</b>             | \$977    | 1080     |
| <b>3636 W</b>        | \$1467   | 1630     |
| <b>P</b>             | \$1172   | 1295     |
| <b>4242 W</b>        | \$1698   | —        |
| <b>P</b>             | \$1346   | —        |
| <b>4848 W</b>        | \$1990   | —        |
| <b>P</b>             | \$1507   | —        |
|                      | <b>P</b> | <b>S</b> |
| <b>DT1JE. 3030 P</b> | \$977    | 1080     |
| <b>3636 P</b>        | \$1172   | 1295     |
| <b>4242 P</b>        | \$1346   | —        |
| <b>4848 P</b>        | \$1507   | —        |

Step 6.

Top Finish

*For laminate top/thermoplastic edge (L)*

|           |                    |      |
|-----------|--------------------|------|
| <b>28</b> | canyon             | +\$0 |
| <b>29</b> | misted             | +\$0 |
| <b>38</b> | twilight           | +\$0 |
| <b>39</b> | desert             | +\$0 |
| <b>76</b> | light brown walnut | +\$0 |
| <b>91</b> | white              | +\$0 |
| <b>98</b> | studio white       | +\$0 |
| <b>1X</b> | vanilla            | +\$0 |
| <b>2X</b> | wheat              | +\$0 |
| <b>3X</b> | celery             | +\$0 |
| <b>4X</b> | coriander          | +\$0 |
| <b>5X</b> | chamomile          | +\$0 |
| <b>6X</b> | cinnamon           | +\$0 |
| <b>7X</b> | cardamom           | +\$0 |
| <b>8X</b> | kale               | +\$0 |
| <b>8Q</b> | folkstone grey     | +\$0 |
| <b>CL</b> | cool grey neutral  | +\$0 |

|            |                            |      |
|------------|----------------------------|------|
| <b>HF</b>  | inner tone light           | +\$0 |
| <b>HM</b>  | natural maple              | +\$0 |
| <b>HP</b>  | light anigre               | +\$0 |
| <b>HT</b>  | inner tone                 | +\$0 |
| <b>HX</b>  | aged cherry                | +\$0 |
| <b>HY</b>  | walnut on cherry           | +\$0 |
| <b>J4</b>  | frosted light grey         | +\$0 |
| <b>J5</b>  | frosted inner tone light   | +\$0 |
| <b>J7</b>  | frosted medium tone        | +\$0 |
| <b>LA</b>  | light ash                  | +\$0 |
| <b>LBA</b> | clear on ash               | +\$0 |
| <b>LBU</b> | medium matte walnut        | +\$0 |
| <b>LBB</b> | oak on ash                 | +\$0 |
| <b>LBC</b> | walnut on ash              | +\$0 |
| <b>LBD</b> | dark brown walnut          | +\$0 |
| <b>LBE</b> | medium red walnut          | +\$0 |
| <b>LBF</b> | neutral twill              | +\$0 |
| <b>LBG</b> | sarum twill                | +\$0 |
| <b>LBH</b> | earthen twill              | +\$0 |
| <b>LBJ</b> | graphite twill             | +\$0 |
| <b>LBK</b> | pewter mesh                | +\$0 |
| <b>LBL</b> | steel mesh                 | +\$0 |
| <b>LBM</b> | crisp linen                | +\$0 |
| <b>LBN</b> | classic linen              | +\$0 |
| <b>LBP</b> | casual linen               | +\$0 |
| <b>LBQ</b> | white twill                | +\$0 |
| <b>LG</b>  | light grey (discontinuing) | +\$0 |
| <b>LM</b>  | mahogany                   | +\$0 |
| <b>LT</b>  | light tone                 | +\$0 |
| <b>LU</b>  | soft white                 | +\$0 |
| <b>MT</b>  | medium tone                | +\$0 |
| <b>OG</b>  | honey maple                | +\$0 |
| <b>WL</b>  | sandstone                  | +\$0 |
| <b>WN</b>  | warm grey neutral          | +\$0 |
| <b>X1</b>  | chalk white                | +\$0 |

Top/Edge Finish: Wood Veneer

*For veneer top/veneer edge (W)*

|           |                    |       |
|-----------|--------------------|-------|
| <b>2U</b> | light brown walnut | +\$85 |
| <b>40</b> | dark brown walnut  | +\$85 |
| <b>ED</b> | aged cherry        | +\$85 |
| <b>EK</b> | medium red walnut  | +\$85 |
| <b>ET</b> | clear on ash       | +\$85 |
| <b>EU</b> | oak on ash         | +\$85 |
| <b>EV</b> | walnut on ash      | +\$85 |
| <b>UL</b> | natural maple      | +\$85 |
| <b>UX</b> | walnut on cherry   | +\$85 |

# Soft Square Table *continued*

Everywhere™ Standard-Height Tables

## Top/Edge Finish: Opaque Formcoat®

*For painted Formcoat® top/edge (P)*

|           |                   |      |
|-----------|-------------------|------|
| <b>8Q</b> | folkstone grey    | +\$0 |
| <b>91</b> | white             | +\$0 |
| <b>CL</b> | cool grey neutral | +\$0 |
| <b>LU</b> | soft white        | +\$0 |
| <b>WL</b> | sandstone         | +\$0 |
| <b>WN</b> | warm grey neutral | +\$0 |

## Step 7. Edge Finish

*For laminate top/thermoplastic edge (L)*

|            |                     |      |
|------------|---------------------|------|
| <b>76</b>  | light brown walnut  | +\$0 |
| <b>8Q</b>  | folkstone grey      | +\$0 |
| <b>91</b>  | white               | +\$0 |
| <b>98</b>  | studio white        | +\$0 |
| <b>CL</b>  | cool grey neutral   | +\$0 |
| <b>LA</b>  | light ash           | +\$0 |
| <b>LBA</b> | clear on ash        | +\$0 |
| <b>LBU</b> | medium matte walnut | +\$0 |
| <b>LBB</b> | oak on ash          | +\$0 |
| <b>LBC</b> | walnut on ash       | +\$0 |
| <b>LBD</b> | dark brown walnut   | +\$0 |
| <b>LBE</b> | medium red walnut   | +\$0 |
| <b>LBF</b> | neutral twill       | +\$0 |
| <b>LBG</b> | sarum twill         | +\$0 |
| <b>LBH</b> | earthen twill       | +\$0 |
| <b>LBJ</b> | graphite twill      | +\$0 |
| <b>LBK</b> | pewter mesh         | +\$0 |
| <b>LBL</b> | steel mesh          | +\$0 |
| <b>LBM</b> | crisp linen         | +\$0 |
| <b>LBN</b> | classic linen       | +\$0 |
| <b>LBP</b> | casual linen        | +\$0 |
| <b>LBQ</b> | white twill         | +\$0 |
| <b>WL</b>  | sandstone           | +\$0 |
| <b>WN</b>  | warm grey neutral   | +\$0 |
| <b>HF</b>  | inner tone light    | +\$0 |
| <b>HM</b>  | natural maple       | +\$0 |
| <b>HP</b>  | light anigre        | +\$0 |
| <b>HT</b>  | inner tone          | +\$0 |
| <b>HX</b>  | aged cherry         | +\$0 |
| <b>HY</b>  | walnut on cherry    | +\$0 |
| <b>LU</b>  | soft white          | +\$0 |

## Step 8. Leg Finish

|           |  |        |
|-----------|--|--------|
| <b>8Q</b> | folkstone grey   | +\$0   |
| <b>91</b> | white  | +\$0   |
| <b>98</b> | studio white <span style="border: 1px solid black; padding: 0 2px;">A</span> | +\$0   |
| <b>BU</b> | black umber  | +\$0   |
| <b>CL</b> | cool grey neutral  | +\$0   |
| <b>G2</b> | graphite satin   | +\$0   |
| <b>HF</b> | inner tone light   | +\$0   |
| <b>LU</b> | soft white   | +\$0   |
| <b>MT</b> | medium tone  | +\$0   |
| <b>SG</b> | slate grey   | +\$0   |
| <b>WL</b> | sandstone  | +\$0   |
| <b>WN</b> | warm grey neutral  | +\$0   |
| <b>CN</b> | metallic champagne   | +\$20  |
| <b>EH</b> | metallic bronze  | +\$20  |
| <b>MS</b> | metallic silver  | +\$20  |
| <b>CD</b> | polished aluminum  | +\$110 |

## Step 9. Casters/Glides

|           |         |      |
|-----------|---------|------|
| <b>20</b> | casters | +\$0 |
| <b>57</b> | glides  | +\$0 |

# Tear Drop Table

DT1KE.  
DT1KS.  
DT1KT.

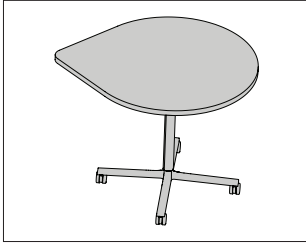

### Product Information

#### Description

This tear drop table comes in multiple edge styles and has a laminate top with thermoplastic edge, veneer top and edge, or painted top and edge. It has multiple leg/base options, and is available with casters or glides. The caster option has 2 locking and 2 non-locking casters. Glides have 1/2" leveling range. Shipped knocked down.

#### Notes

For additional details on available edge options see Appendices.

For additional size, edge, and finish options, see Vary Easy Program in Appendices.

#### Dimensions

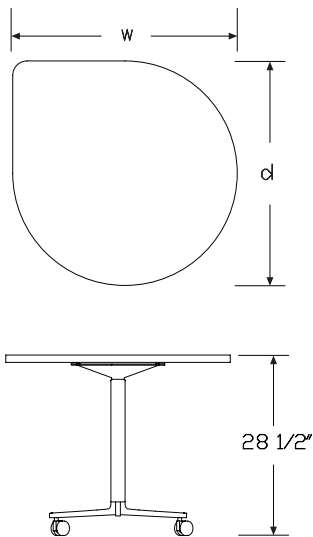

### Specification Information

#### Step 1.

**DT1K** A

#### Step 2. Edge

- S.** squared-edge
- T.** thin-edge
- E.** eased-edge

#### Step 3. Diameter

- 30** 30" diameter
- 36** 36" diameter

#### Step 4. Surface Material

##### For eased-edge (E.)

- P** painted Formcoat® top/edge

##### For thin-edge (T.)

- W** veneer top/veneer edge
- P** painted Formcoat® top/edge

##### For squared-edge (S.)

- L** laminate top/thermoplastic edge
- W** veneer top/veneer edge
- P** painted Formcoat® top/edge

#### Step 5. Leg/Base Type

- S** single-column base A

#### Prices for Steps 1-5.

|                    | <b>S</b> |
|--------------------|----------|
| <b>DT1KS. 30 L</b> | \$903    |
| <b>W</b>           | \$1145   |
| <b>P</b>           | \$1037   |
| <b>36 L</b>        | \$1033   |
| <b>W</b>           | \$1390   |
| <b>P</b>           | \$1189   |
|                    | <b>S</b> |
| <b>DT1KT. 30 W</b> | \$1376   |
| <b>P</b>           | \$1104   |
| <b>36 W</b>        | \$1667   |
| <b>P</b>           | \$1266   |
|                    | <b>S</b> |
| <b>DT1KE. 30 P</b> | \$1104   |

# Tear Drop Table *continued*

Everywhere™ Standard-Height Tables

**36 P** \$1266

Step 6.

Top Finish

*For laminate top/thermoplastic edge (L)*

|            |                          |      |
|------------|--------------------------|------|
| <b>28</b>  | canyon                   | +\$0 |
| <b>29</b>  | misted                   | +\$0 |
| <b>38</b>  | twilight                 | +\$0 |
| <b>39</b>  | desert                   | +\$0 |
| <b>76</b>  | light brown walnut       | +\$0 |
| <b>91</b>  | white                    | +\$0 |
| <b>98</b>  | studio white             | +\$0 |
| <b>1X</b>  | vanilla                  | +\$0 |
| <b>2X</b>  | wheat                    | +\$0 |
| <b>3X</b>  | celery                   | +\$0 |
| <b>4X</b>  | coriander                | +\$0 |
| <b>5X</b>  | chamomile                | +\$0 |
| <b>6X</b>  | cinnamon                 | +\$0 |
| <b>7X</b>  | cardamom                 | +\$0 |
| <b>8X</b>  | kale                     | +\$0 |
| <b>8Q</b>  | folkstone grey           | +\$0 |
| <b>CL</b>  | cool grey neutral        | +\$0 |
| <b>HF</b>  | inner tone light         | +\$0 |
| <b>HM</b>  | natural maple            | +\$0 |
| <b>HP</b>  | light anigre             | +\$0 |
| <b>HT</b>  | inner tone               | +\$0 |
| <b>HX</b>  | aged cherry              | +\$0 |
| <b>HY</b>  | walnut on cherry         | +\$0 |
| <b>J4</b>  | frosted light grey       | +\$0 |
| <b>J5</b>  | frosted inner tone light | +\$0 |
| <b>J7</b>  | frosted medium tone      | +\$0 |
| <b>LA</b>  | light ash                | +\$0 |
| <b>LBA</b> | clear on ash             | +\$0 |
| <b>LBU</b> | medium matte walnut      | +\$0 |
| <b>LBB</b> | oak on ash               | +\$0 |
| <b>LBC</b> | walnut on ash            | +\$0 |
| <b>LBD</b> | dark brown walnut        | +\$0 |
| <b>LBE</b> | medium red walnut        | +\$0 |
| <b>LBF</b> | neutral twill            | +\$0 |
| <b>LBG</b> | sarum twill              | +\$0 |
| <b>LBH</b> | earthen twill            | +\$0 |
| <b>LBJ</b> | graphite twill           | +\$0 |
| <b>LBK</b> | pewter mesh              | +\$0 |
| <b>LBL</b> | steel mesh               | +\$0 |
| <b>LBM</b> | crisp linen              | +\$0 |
| <b>LBN</b> | classic linen            | +\$0 |

|            |                            |      |
|------------|----------------------------|------|
| <b>LBP</b> | casual linen               | +\$0 |
| <b>LBQ</b> | white twill                | +\$0 |
| <b>LG</b>  | light grey (discontinuing) | +\$0 |
| <b>LM</b>  | mahogany                   | +\$0 |
| <b>LT</b>  | light tone                 | +\$0 |
| <b>LU</b>  | soft white                 | +\$0 |
| <b>MT</b>  | medium tone                | +\$0 |
| <b>OG</b>  | honey maple                | +\$0 |
| <b>WL</b>  | sandstone                  | +\$0 |
| <b>WN</b>  | warm grey neutral          | +\$0 |
| <b>X1</b>  | chalk white                | +\$0 |

Top/Edge Finish: Opaque Formcoat®

*For painted Formcoat® top/edge (P)*

|           |                   |      |
|-----------|-------------------|------|
| <b>8Q</b> | folkstone grey    | +\$0 |
| <b>91</b> | white             | +\$0 |
| <b>CL</b> | cool grey neutral | +\$0 |
| <b>LU</b> | soft white        | +\$0 |
| <b>WL</b> | sandstone         | +\$0 |
| <b>WN</b> | warm grey neutral | +\$0 |

Top/Edge Finish: Wood Veneer

*For veneer top/veneer edge (W)*

|           |  |       |
|-----------|--|-------|
| <b>2U</b> | light brown walnut <span style="border: 1px solid black; padding: 0 2px;">A</span> | +\$85 |
| <b>40</b> | dark brown walnut <span style="border: 1px solid black; padding: 0 2px;">A</span>  | +\$85 |
| <b>ED</b> | aged cherry <span style="border: 1px solid black; padding: 0 2px;">A</span>        | +\$85 |
| <b>EK</b> | medium red walnut <span style="border: 1px solid black; padding: 0 2px;">A</span>  | +\$85 |
| <b>ET</b> | clear on ash   | +\$85 |
| <b>EU</b> | oak on ash   | +\$85 |
| <b>EV</b> | walnut on ash  | +\$85 |
| <b>EY</b> | light anigre <span style="border: 1px solid black; padding: 0 2px;">A</span>       | +\$85 |
| <b>UL</b> | natural maple <span style="border: 1px solid black; padding: 0 2px;">A</span>      | +\$85 |
| <b>UX</b> | walnut on cherry <span style="border: 1px solid black; padding: 0 2px;">A</span>   | +\$85 |

# Tear Drop Table *continued*

| Step 7. Edge Finish                            |                     |      |
|--|---------------------|------|
| <i>For laminate top/thermoplastic edge (L)</i> |                     |      |
| <b>76</b>                                      | light brown walnut  | +\$0 |
| <b>8Q</b>                                      | folkstone grey      | +\$0 |
| <b>91</b>                                      | white               | +\$0 |
| <b>98</b>                                      | studio white        | +\$0 |
| <b>CL</b>                                      | cool grey neutral   | +\$0 |
| <b>LA</b>                                      | light ash           | +\$0 |
| <b>LBA</b>                                     | clear on ash        | +\$0 |
| <b>LBU</b>                                     | medium matte walnut | +\$0 |
| <b>LBB</b>                                     | oak on ash          | +\$0 |
| <b>LBC</b>                                     | walnut on ash       | +\$0 |
| <b>LBD</b>                                     | dark brown walnut   | +\$0 |
| <b>LBE</b>                                     | medium red walnut   | +\$0 |
| <b>LBF</b>                                     | neutral twill       | +\$0 |
| <b>LBG</b>                                     | sarum twill         | +\$0 |
| <b>LBH</b>                                     | earthen twill       | +\$0 |
| <b>LBJ</b>                                     | graphite twill      | +\$0 |
| <b>LBK</b>                                     | pewter mesh         | +\$0 |
| <b>LBL</b>                                     | steel mesh          | +\$0 |
| <b>LBM</b>                                     | crisp linen         | +\$0 |
| <b>LBN</b>                                     | classic linen       | +\$0 |
| <b>LBP</b>                                     | casual linen        | +\$0 |
| <b>LBQ</b>                                     | white twill         | +\$0 |
| <b>WL</b>                                      | sandstone           | +\$0 |
| <b>WN</b>                                      | warm grey neutral   | +\$0 |
| <b>HF</b>                                      | inner tone light    | +\$0 |
| <b>HM</b>                                      | natural maple       | +\$0 |
| <b>HP</b>                                      | light anigre        | +\$0 |
| <b>HT</b>                                      | inner tone          | +\$0 |
| <b>HX</b>                                      | aged cherry         | +\$0 |
| <b>HY</b>                                      | walnut on cherry    | +\$0 |
| <b>LU</b>                                      | soft white          | +\$0 |

| Step 8. Leg/Base Finish |  |        |
|-------------------------|--|--------|
| <b>8Q</b>               | folkstone grey   | +\$0   |
| <b>91</b>               | white  | +\$0   |
| <b>98</b>               | studio white <span style="border: 1px solid black; padding: 0 2px;">A</span> | +\$0   |
| <b>BU</b>               | black umber  | +\$0   |
| <b>CL</b>               | cool grey neutral  | +\$0   |
| <b>G2</b>               | graphite satin   | +\$0   |
| <b>HF</b>               | inner tone light   | +\$0   |
| <b>LU</b>               | soft white   | +\$0   |
| <b>MT</b>               | medium tone  | +\$0   |
| <b>SG</b>               | slate grey   | +\$0   |
| <b>WL</b>               | sandstone  | +\$0   |
| <b>WN</b>               | warm grey neutral  | +\$0   |
| <b>CN</b>               | metallic champagne   | +\$20  |
| <b>EH</b>               | metallic bronze  | +\$20  |
| <b>MS</b>               | metallic silver  | +\$20  |
| <b>CD</b>               | polished aluminum  | +\$110 |

| Step 9. Casters/Glides |         |      |
|------------------------|---------|------|
| <b>20</b>              | casters | +\$0 |
| <b>57</b>              | glides  | +\$0 |

Everywhere™ Standard-Height Tables

# Classroom Curve Table

DT1LE.  
DT1LS.  
DT1LT.

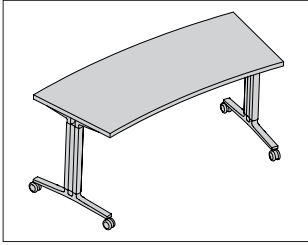

### Product Information

**Description**  
This classroom table comes in multiple edge styles and has a laminate top with thermoplastic edge, veneer top and edge, or painted top and edge. It has multiple leg options, and is available with casters or glides. The caster option has 2 locking and 2 non-locking casters. Glides have 1/2" leveling range. Shipped knocked down. Height-adjustable legs have a 5" range in 1" increments.

**Notes**  
Cable grommet options available through Vary Easy Program for round pass through grommet with 2 1/4" hole clearance. Holes are located 3" from rear edge and 6" from end for the L and R options. Covers not provided with painted surface option. Reinforcement channels are used under table tops 54" and wider. They will be located along the center line for 18" deep and 24" deep surfaces, and 19" from the front edge for 30" deep surfaces. For additional details on available edge options see Appendices. For additional size, edge, finish, and cable management options, see Vary Easy Program in Appendices. UL listed when used with Connect™ single circuit electrical product (Y137x.) with post leg (P) and T-leg (T) options.

### Dimensions

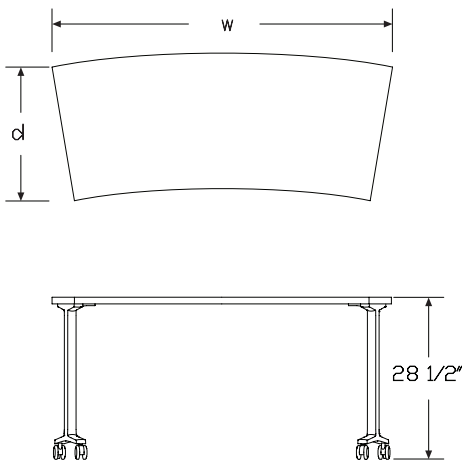

### Specification Information

#### Step 1.

**DT1L**

#### Step 2. Edge

- S.** squared-edge
- T.** thin-edge
- E.** eased-edge

#### Step 3. Depth

##### For squared-edge (S.)

- 18** 18" deep
- 24** 24" deep

##### For thin-edge (T.)

- 24** 24" deep

##### For eased-edge (E.)

- 24** 24" deep

#### Step 4. Width

##### For 18" deep (18)

- 60** 60" wide

##### For 24" deep (24)

- 48** 48" wide
- 60** 60" wide

#### Step 5. Surface Material

##### For squared-edge (S.)

- L** laminate top/thermoplastic edge
- W** veneer top/veneer edge **A**
- P** painted Formcoat® top/edge

##### For thin-edge (T.)

- W** veneer top/veneer edge **A**
- P** painted Formcoat® top/edge

##### For eased-edge (E.)

- P** painted Formcoat® top/edge

Classroom Curve Table *continued*

Step 6. Leg Type

For 18" deep (18)

**P** post leg

For 24" deep (24)

**P** post leg

**T** T-leg

**A** T-leg with height adjustment

Prices for Steps 1-6.

|                     | LP     | LT   | LA   | WP   | WT   | WA   |
|---------------------|--------|------|------|------|------|------|
| <b>DT1LS. 18 60</b> | \$1017 | —    | —    | 1247 | —    | —    |
| <b>24 48</b>        | \$1018 | 1322 | 1654 | 1249 | 1645 | 2074 |
| <b>60</b>           | \$1144 | 1488 | 1858 | 1413 | 1858 | 2342 |

|                     | PP     | PT   | PA   |
|---------------------|--------|------|------|
| <b>DT1LS. 18 60</b> | \$1169 | —    | —    |
| <b>24 48</b>        | \$1170 | 1521 | 1902 |
| <b>60</b>           | \$1316 | 1710 | 2135 |

|                     | LP | LT | LA | WP     | WT   | WA   |
|---------------------|----|----|----|--------|------|------|
| <b>DT1LT. 24 48</b> | —  | —  | —  | \$1499 | 1975 | 2488 |
| <b>60</b>           | —  | —  | —  | \$1695 | 2228 | 2808 |

|                     | PP     | PT   | PA   |
|---------------------|--------|------|------|
| <b>DT1LT. 24 48</b> | \$1246 | 1621 | 2025 |
| <b>60</b>           | \$1401 | 1821 | 2275 |

|                     | PP     | PT   | PA   |
|---------------------|--------|------|------|
| <b>DT1LE. 24 48</b> | \$1246 | 1621 | 2025 |
| <b>60</b>           | \$1401 | 1821 | 2275 |

Step 7.

Top Finish

For laminate top/thermoplastic edge (L)

|           |                    |      |
|-----------|--------------------|------|
| <b>28</b> | canyon             | +\$0 |
| <b>29</b> | misted             | +\$0 |
| <b>38</b> | twilight           | +\$0 |
| <b>39</b> | desert             | +\$0 |
| <b>76</b> | light brown walnut | +\$0 |
| <b>91</b> | white              | +\$0 |
| <b>98</b> | studio white       | +\$0 |
| <b>1X</b> | vanilla            | +\$0 |
| <b>2X</b> | wheat              | +\$0 |
| <b>3X</b> | celery             | +\$0 |

|            |                            |      |
|------------|----------------------------|------|
| <b>4X</b>  | coriander                  | +\$0 |
| <b>5X</b>  | chamomile                  | +\$0 |
| <b>6X</b>  | cinnamon                   | +\$0 |
| <b>7X</b>  | cardamom                   | +\$0 |
| <b>8X</b>  | kale                       | +\$0 |
| <b>8Q</b>  | folkstone grey             | +\$0 |
| <b>CL</b>  | cool grey neutral          | +\$0 |
| <b>HF</b>  | inner tone light           | +\$0 |
| <b>HM</b>  | natural maple              | +\$0 |
| <b>HP</b>  | light anigre               | +\$0 |
| <b>HT</b>  | inner tone                 | +\$0 |
| <b>HX</b>  | aged cherry                | +\$0 |
| <b>HY</b>  | walnut on cherry           | +\$0 |
| <b>J4</b>  | frosted light grey         | +\$0 |
| <b>J5</b>  | frosted inner tone light   | +\$0 |
| <b>J7</b>  | frosted medium tone        | +\$0 |
| <b>LA</b>  | light ash                  | +\$0 |
| <b>LBA</b> | clear on ash               | +\$0 |
| <b>LBU</b> | medium matte walnut        | +\$0 |
| <b>LBB</b> | oak on ash                 | +\$0 |
| <b>LBC</b> | walnut on ash              | +\$0 |
| <b>LBD</b> | dark brown walnut          | +\$0 |
| <b>LBE</b> | medium red walnut          | +\$0 |
| <b>LBF</b> | neutral twill              | +\$0 |
| <b>LBG</b> | sarum twill                | +\$0 |
| <b>LBH</b> | earthen twill              | +\$0 |
| <b>LBJ</b> | graphite twill             | +\$0 |
| <b>LBK</b> | pewter mesh                | +\$0 |
| <b>LBL</b> | steel mesh                 | +\$0 |
| <b>LBM</b> | crisp linen                | +\$0 |
| <b>LBN</b> | classic linen              | +\$0 |
| <b>LBP</b> | casual linen               | +\$0 |
| <b>LBQ</b> | white twill                | +\$0 |
| <b>LG</b>  | light grey (discontinuing) | +\$0 |
| <b>LM</b>  | mahogany                   | +\$0 |
| <b>LT</b>  | light tone                 | +\$0 |
| <b>LU</b>  | soft white                 | +\$0 |
| <b>MT</b>  | medium tone                | +\$0 |
| <b>OG</b>  | honey maple                | +\$0 |
| <b>WL</b>  | sandstone                  | +\$0 |
| <b>WN</b>  | warm grey neutral          | +\$0 |
| <b>X1</b>  | chalk white                | +\$0 |

# Classroom Curve Table *continued*

Everywhere™ Standard-Height Tables

| Top/Edge Finish: Wood Veneer          |   |       |
|---------------------------------------|---|-------|
| <i>For veneer top/veneer edge (W)</i> |   |       |
| <b>2U</b>                             | light brown walnut <input type="checkbox"/> A | +\$85 |
| <b>40</b>                             | dark brown walnut <input type="checkbox"/> A  | +\$85 |
| <b>ED</b>                             | aged cherry <input type="checkbox"/> A        | +\$85 |
| <b>EK</b>                             | medium red walnut <input type="checkbox"/> A  | +\$85 |
| <b>ET</b>                             | clear on ash <input type="checkbox"/> A       | +\$85 |
| <b>EU</b>                             | oak on ash <input type="checkbox"/> A         | +\$85 |
| <b>EV</b>                             | walnut on ash <input type="checkbox"/> A      | +\$85 |
| <b>UL</b>                             | natural maple <input type="checkbox"/> A      | +\$85 |
| <b>UX</b>                             | walnut on cherry <input type="checkbox"/> A   | +\$85 |

| Top/Edge Finish: Opaque Formcoat®         |                   |      |
|---|-------------------|------|
| <i>For painted Formcoat® top/edge (P)</i> |                   |      |
| <b>8Q</b>                                 | folkstone grey    | +\$0 |
| <b>91</b>                                 | white             | +\$0 |
| <b>CL</b>                                 | cool grey neutral | +\$0 |
| <b>LU</b>                                 | soft white        | +\$0 |
| <b>WL</b>                                 | sandstone         | +\$0 |
| <b>WN</b>                                 | warm grey neutral | +\$0 |

| Step 8. Edge Finish                            |                     |      |
|--|---------------------|------|
| <i>For laminate top/thermoplastic edge (L)</i> |                     |      |
| <b>76</b>                                      | light brown walnut  | +\$0 |
| <b>8Q</b>                                      | folkstone grey      | +\$0 |
| <b>91</b>                                      | white               | +\$0 |
| <b>98</b>                                      | studio white        | +\$0 |
| <b>CL</b>                                      | cool grey neutral   | +\$0 |
| <b>LA</b>                                      | light ash           | +\$0 |
| <b>LBA</b>                                     | clear on ash        | +\$0 |
| <b>LBU</b>                                     | medium matte walnut | +\$0 |
| <b>LBB</b>                                     | oak on ash          | +\$0 |
| <b>LBC</b>                                     | walnut on ash       | +\$0 |
| <b>LBD</b>                                     | dark brown walnut   | +\$0 |
| <b>LBE</b>                                     | medium red walnut   | +\$0 |
| <b>LBF</b>                                     | neutral twill       | +\$0 |
| <b>LBG</b>                                     | sarum twill         | +\$0 |
| <b>LBH</b>                                     | earthen twill       | +\$0 |
| <b>LBJ</b>                                     | graphite twill      | +\$0 |
| <b>LBK</b>                                     | pewter mesh         | +\$0 |
| <b>LBL</b>                                     | steel mesh          | +\$0 |
| <b>LBM</b>                                     | crisp linen         | +\$0 |
| <b>LBN</b>                                     | classic linen       | +\$0 |
| <b>LBP</b>                                     | casual linen        | +\$0 |
| <b>LBQ</b>                                     | white twill         | +\$0 |
| <b>WL</b>                                      | sandstone           | +\$0 |
| <b>WN</b>                                      | warm grey neutral   | +\$0 |
| <b>HF</b>                                      | inner tone light    | +\$0 |
| <b>HM</b>                                      | natural maple       | +\$0 |
| <b>HP</b>                                      | light anigre        | +\$0 |
| <b>HT</b>                                      | inner tone          | +\$0 |
| <b>HX</b>                                      | aged cherry         | +\$0 |
| <b>HY</b>                                      | walnut on cherry    | +\$0 |
| <b>LU</b>                                      | soft white          | +\$0 |



## Classroom Curve Table *continued*

| Step 9. Leg Finish      |   |        |
|-------------------------|---|--------|
| <b>8Q</b>               | folkstone grey                          | +\$0   |
| <b>91</b>               | white                                   | +\$0   |
| <b>98</b>               | studio white <input type="checkbox"/> A | +\$0   |
| <b>BU</b>               | black umber                             | +\$0   |
| <b>CL</b>               | cool grey neutral                       | +\$0   |
| <b>G2</b>               | graphite satin                          | +\$0   |
| <b>HF</b>               | inner tone light                        | +\$0   |
| <b>LU</b>               | soft white                              | +\$0   |
| <b>MT</b>               | medium tone                             | +\$0   |
| <b>SG</b>               | slate grey                              | +\$0   |
| <b>WL</b>               | sandstone                               | +\$0   |
| <b>WN</b>               | warm grey neutral                       | +\$0   |
| <b>CN</b>               | metallic champagne                      | +\$20  |
| <b>EH</b>               | metallic bronze                         | +\$20  |
| <b>MS</b>               | metallic silver                         | +\$20  |
| <b>CD</b>               | polished aluminum                       | +\$110 |
| Step 10. Casters/Glides |   |        |
| <b>20</b>               | casters                                 | +\$0   |
| <b>57</b>               | glides                                  | +\$0   |

# Conference Corner Table

DT1ME.  
DT1MS.  
DT1MT.

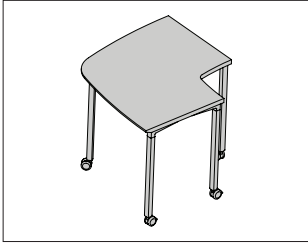

Everywhere™ Standard-Height Tables

### Product Information

#### Description

This corner table comes in multiple edge styles and has a laminate top with thermoplastic edge, veneer top and edge, or painted top and edge. It has multiple leg/base options, and is available with casters or glides. The caster option has 2 locking and 2 non-locking casters. Glides have 1/2" leveling range. Shipped knocked down.

#### Notes

Tables have an additional (5th) leg for stability.

Additional ganging bracket kits (Y1338.) can be used with adjacent tables.

For additional details on available edge options see Appendices.

#### Dimensions

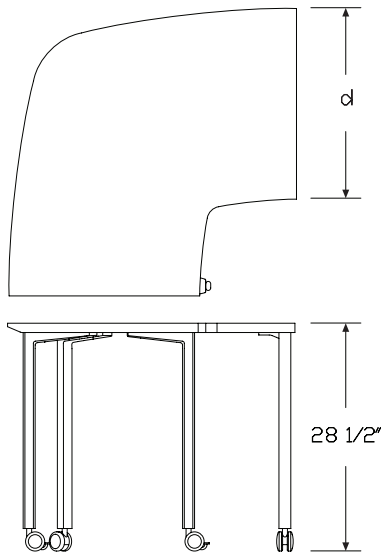

### Specification Information

#### Step 1.

#### DT1M

#### Step 2. Edge

- S. squared-edge
- T. thin-edge
- E. eased-edge

#### Step 3. Depth

- 24 24" deep
- 30 30" deep

#### Step 4. Surface Material

#### For squared-edge (S.)

- L laminate top/thermoplastic edge
- W veneer top/veneer edge  A
- P painted Formcoat® top/edge

#### For thin-edge (T.)

- W veneer top/veneer edge  A
- P painted Formcoat® top/edge

#### For eased-edge (E.)

- P painted Formcoat® top/edge

#### Step 5. Leg/Base Type

- P post leg

#### Prices for Steps 1-5.

|            | P      |
|------------|--------|
| DT1MS.24 L | \$1141 |
| W          | \$1442 |
| P          | \$1313 |
| 30 L       | \$1370 |
| W          | \$1750 |
| P          | \$1574 |
|            | P      |
| DT1MT.24 W | \$1731 |
| P          | \$1397 |
| 30 W       | \$2101 |
| P          | \$1676 |
|            | P      |
| DT1ME.24 P | \$1397 |

Conference Corner Table *continued*

|  |                          |        |
|--|--------------------------|--------|
| <b>30 P</b>                                    |                          | \$1676 |
| Step 6.  |                          |        |
| Top Finish                                     |                          |        |
| <i>For laminate top/thermoplastic edge (L)</i> |                          |        |
| <b>28</b>                                      | canyon                   | +\$0   |
| <b>29</b>                                      | misted                   | +\$0   |
| <b>38</b>                                      | twilight                 | +\$0   |
| <b>39</b>                                      | desert                   | +\$0   |
| <b>76</b>                                      | light brown walnut       | +\$0   |
| <b>91</b>                                      | white                    | +\$0   |
| <b>98</b>                                      | studio white             | +\$0   |
| <b>1X</b>                                      | vanilla                  | +\$0   |
| <b>2X</b>                                      | wheat                    | +\$0   |
| <b>3X</b>                                      | celery                   | +\$0   |
| <b>4X</b>                                      | coriander                | +\$0   |
| <b>5X</b>                                      | chamomile                | +\$0   |
| <b>6X</b>                                      | cinnamon                 | +\$0   |
| <b>7X</b>                                      | cardamom                 | +\$0   |
| <b>8X</b>                                      | kale                     | +\$0   |
| <b>8Q</b>                                      | folkstone grey           | +\$0   |
| <b>CL</b>                                      | cool grey neutral        | +\$0   |
| <b>HF</b>                                      | inner tone light         | +\$0   |
| <b>HM</b>                                      | natural maple            | +\$0   |
| <b>HP</b>                                      | light anigre             | +\$0   |
| <b>HT</b>                                      | inner tone               | +\$0   |
| <b>HX</b>                                      | aged cherry              | +\$0   |
| <b>HY</b>                                      | walnut on cherry         | +\$0   |
| <b>J4</b>                                      | frosted light grey       | +\$0   |
| <b>J5</b>                                      | frosted inner tone light | +\$0   |
| <b>J7</b>                                      | frosted medium tone      | +\$0   |
| <b>LA</b>                                      | light ash                | +\$0   |
| <b>LBA</b>                                     | clear on ash             | +\$0   |
| <b>LBU</b>                                     | medium matte walnut      | +\$0   |
| <b>LBB</b>                                     | oak on ash               | +\$0   |
| <b>LBC</b>                                     | walnut on ash            | +\$0   |
| <b>LBD</b>                                     | dark brown walnut        | +\$0   |
| <b>LBE</b>                                     | medium red walnut        | +\$0   |
| <b>LBF</b>                                     | neutral twill            | +\$0   |
| <b>LBG</b>                                     | sarum twill              | +\$0   |
| <b>LBH</b>                                     | earthen twill            | +\$0   |
| <b>LBJ</b>                                     | graphite twill           | +\$0   |
| <b>LBK</b>                                     | pewter mesh              | +\$0   |
| <b>LBL</b>                                     | steel mesh               | +\$0   |
| <b>LBM</b>                                     | crisp linen              | +\$0   |
| <b>LBN</b>                                     | classic linen            | +\$0   |

|            |                            |      |
|------------|----------------------------|------|
| <b>LBP</b> | casual linen               | +\$0 |
| <b>LBQ</b> | white twill                | +\$0 |
| <b>LG</b>  | light grey (discontinuing) | +\$0 |
| <b>LM</b>  | mahogany                   | +\$0 |
| <b>LT</b>  | light tone                 | +\$0 |
| <b>LU</b>  | soft white                 | +\$0 |
| <b>MT</b>  | medium tone                | +\$0 |
| <b>OG</b>  | honey maple                | +\$0 |
| <b>WL</b>  | sandstone                  | +\$0 |
| <b>WN</b>  | warm grey neutral          | +\$0 |
| <b>X1</b>  | chalk white                | +\$0 |

|                                       |   |       |
|---------------------------------------|---|-------|
| Top/Edge Finish: Wood Veneer          |   |       |
| <i>For veneer top/veneer edge (W)</i> |   |       |
| <b>2U</b>                             | light brown walnut <input type="checkbox"/> A | +\$85 |
| <b>40</b>                             | dark brown walnut <input type="checkbox"/> A  | +\$85 |
| <b>ED</b>                             | aged cherry <input type="checkbox"/> A        | +\$85 |
| <b>EK</b>                             | medium red walnut <input type="checkbox"/> A  | +\$85 |
| <b>ET</b>                             | clear on ash <input type="checkbox"/> A       | +\$85 |
| <b>EU</b>                             | oak on ash <input type="checkbox"/> A         | +\$85 |
| <b>EV</b>                             | walnut on ash <input type="checkbox"/> A      | +\$85 |
| <b>UL</b>                             | natural maple <input type="checkbox"/> A      | +\$85 |
| <b>UX</b>                             | walnut on cherry <input type="checkbox"/> A   | +\$85 |

|   |                   |      |
|---|-------------------|------|
| Top/Edge Finish: Opaque Formcoat®         |                   |      |
| <i>For painted Formcoat® top/edge (P)</i> |                   |      |
| <b>8Q</b>                                 | folkstone grey    | +\$0 |
| <b>91</b>                                 | white             | +\$0 |
| <b>CL</b>                                 | cool grey neutral | +\$0 |
| <b>LU</b>                                 | soft white        | +\$0 |
| <b>WL</b>                                 | sandstone         | +\$0 |
| <b>WN</b>                                 | warm grey neutral | +\$0 |

Everywhere™ Standard-Height Tables

Conference Corner Table *continued*

Everywhere™ Standard-Height Tables

| Step 7. Edge Finish                            |                     |      |
|--|---------------------|------|
| <i>For laminate top/thermoplastic edge (L)</i> |                     |      |
| <b>76</b>                                      | light brown walnut  | +\$0 |
| <b>8Q</b>                                      | folkstone grey      | +\$0 |
| <b>91</b>                                      | white               | +\$0 |
| <b>98</b>                                      | studio white        | +\$0 |
| <b>CL</b>                                      | cool grey neutral   | +\$0 |
| <b>LA</b>                                      | light ash           | +\$0 |
| <b>LBA</b>                                     | clear on ash        | +\$0 |
| <b>LBU</b>                                     | medium matte walnut | +\$0 |
| <b>LBB</b>                                     | oak on ash          | +\$0 |
| <b>LBC</b>                                     | walnut on ash       | +\$0 |
| <b>LBD</b>                                     | dark brown walnut   | +\$0 |
| <b>LBE</b>                                     | medium red walnut   | +\$0 |
| <b>LBF</b>                                     | neutral twill       | +\$0 |
| <b>LBG</b>                                     | sarum twill         | +\$0 |
| <b>LBH</b>                                     | earthen twill       | +\$0 |
| <b>LBJ</b>                                     | graphite twill      | +\$0 |
| <b>LBK</b>                                     | pewter mesh         | +\$0 |
| <b>LBL</b>                                     | steel mesh          | +\$0 |
| <b>LBM</b>                                     | crisp linen         | +\$0 |
| <b>LBN</b>                                     | classic linen       | +\$0 |
| <b>LBP</b>                                     | casual linen        | +\$0 |
| <b>LBQ</b>                                     | white twill         | +\$0 |
| <b>WL</b>                                      | sandstone           | +\$0 |
| <b>WN</b>                                      | warm grey neutral   | +\$0 |
| <b>HF</b>                                      | inner tone light    | +\$0 |
| <b>HM</b>                                      | natural maple       | +\$0 |
| <b>HP</b>                                      | light anigre        | +\$0 |
| <b>HT</b>                                      | inner tone          | +\$0 |
| <b>HX</b>                                      | aged cherry         | +\$0 |
| <b>HY</b>                                      | walnut on cherry    | +\$0 |
| <b>LU</b>                                      | soft white          | +\$0 |

| Step 8. Leg/Base Finish |                    |        |
|-------------------------|--------------------|--------|
| <b>8Q</b>               | folkstone grey     | +\$0   |
| <b>91</b>               | white              | +\$0   |
| <b>98</b>               | studio white       | +\$0   |
| <b>BU</b>               | black umber        | +\$0   |
| <b>CL</b>               | cool grey neutral  | +\$0   |
| <b>G2</b>               | graphite satin     | +\$0   |
| <b>HF</b>               | inner tone light   | +\$0   |
| <b>LU</b>               | soft white         | +\$0   |
| <b>MT</b>               | medium tone        | +\$0   |
| <b>SG</b>               | slate grey         | +\$0   |
| <b>WL</b>               | sandstone          | +\$0   |
| <b>WN</b>               | warm grey neutral  | +\$0   |
| <b>CN</b>               | metallic champagne | +\$20  |
| <b>EH</b>               | metallic bronze    | +\$20  |
| <b>MS</b>               | metallic silver    | +\$20  |
| <b>CD</b>               | polished aluminum  | +\$110 |

| Step 9. Casters/Glides |         |      |
|------------------------|---------|------|
| <b>20</b>              | casters | +\$0 |
| <b>57</b>              | glides  | +\$0 |

# Round Corner Table

DT1NE.  
DT1NS.  
DT1NT.

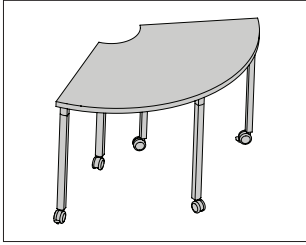

### Product Information

#### Description

This corner table comes in multiple edge styles and has a laminate top with thermoplastic edge, veneer top and edge, or painted top and edge. It has multiple leg/base options, and is available with casters or glides. The caster option has 2 locking and 2 non-locking casters. Glides have 1/2" leveling range. Shipped knocked down.

#### Notes

Tables have an additional (5th) leg for stability.  
 3 36" deep tables ganged together make an 84" diameter table.  
 Additional ganging bracket kits (Y1338.), sold separately, can be used to ensure proper alignment with adjacent tables.  
 For additional details on available edge options see Appendices.  
 UL listed when used with Connect™ single circuit electrical product (Y137x.) with post leg (P) option.

#### Dimensions

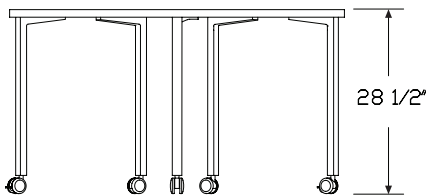
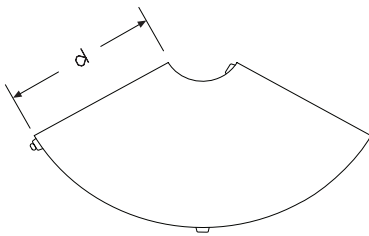

### Specification Information

#### Step 1.

**DT1N**

#### Step 2. Edge

- S.** squared-edge
- T.** thin-edge
- E.** eased-edge

#### Step 3. Depth

- 24** 24" deep
- 30** 30" deep
- 36** 36" deep

#### Step 4. Surface Material

##### For squared-edge (S.)

- L** laminate top/thermoplastic edge
- W** veneer top/veneer edge **A**
- P** painted Formcoat® top/edge

##### For thin-edge (T.)

- W** veneer top/veneer edge **A**
- P** painted Formcoat® top/edge

##### For eased-edge (E.)

- P** painted Formcoat® top/edge

#### Step 5. Leg/Base Type

- P** post leg

#### Prices for Steps 1-5.

|                    | <b>P</b> |
|--------------------|----------|
| <b>DT1NS. 24 L</b> | \$1141   |
| <b>W</b>           | \$1442   |
| <b>P</b>           | \$1313   |
| <b>30 L</b>        | \$1370   |
| <b>W</b>           | \$1750   |
| <b>P</b>           | \$1574   |
| <b>36 L</b>        | \$1598   |
| <b>W</b>           | \$2059   |
| <b>P</b>           | \$1837   |
|                    | <b>P</b> |
| <b>DT1NT. 24 W</b> | \$1731   |
| <b>P</b>           | \$1397   |

Round Corner Table *continued*

Everywhere™ Standard-Height Tables

|                    |          |
|--------------------|----------|
| <b>30 W</b>        | \$2101   |
| <b>P</b>           | \$1676   |
| <b>36 W</b>        | \$2470   |
| <b>P</b>           | \$1956   |
|                    | <b>P</b> |
| <b>DT1NE. 24 P</b> | \$1397   |
| <b>30 P</b>        | \$1676   |
| <b>36 P</b>        | \$1956   |

Step 6.

Top Finish

*For laminate top/thermoplastic edge (L)*

|            |                          |      |
|------------|--------------------------|------|
| <b>28</b>  | canyon                   | +\$0 |
| <b>29</b>  | misted                   | +\$0 |
| <b>38</b>  | twilight                 | +\$0 |
| <b>39</b>  | desert                   | +\$0 |
| <b>76</b>  | light brown walnut       | +\$0 |
| <b>91</b>  | white                    | +\$0 |
| <b>98</b>  | studio white             | +\$0 |
| <b>1X</b>  | vanilla                  | +\$0 |
| <b>2X</b>  | wheat                    | +\$0 |
| <b>3X</b>  | celery                   | +\$0 |
| <b>4X</b>  | coriander                | +\$0 |
| <b>5X</b>  | chamomile                | +\$0 |
| <b>6X</b>  | cinnamon                 | +\$0 |
| <b>7X</b>  | cardamom                 | +\$0 |
| <b>8X</b>  | kale                     | +\$0 |
| <b>8Q</b>  | folkstone grey           | +\$0 |
| <b>CL</b>  | cool grey neutral        | +\$0 |
| <b>HF</b>  | inner tone light         | +\$0 |
| <b>HM</b>  | natural maple            | +\$0 |
| <b>HP</b>  | light anigre             | +\$0 |
| <b>HT</b>  | inner tone               | +\$0 |
| <b>HX</b>  | aged cherry              | +\$0 |
| <b>HY</b>  | walnut on cherry         | +\$0 |
| <b>J4</b>  | frosted light grey       | +\$0 |
| <b>J5</b>  | frosted inner tone light | +\$0 |
| <b>J7</b>  | frosted medium tone      | +\$0 |
| <b>LA</b>  | light ash                | +\$0 |
| <b>LBA</b> | clear on ash             | +\$0 |
| <b>LBU</b> | medium matte walnut      | +\$0 |
| <b>LBB</b> | oak on ash               | +\$0 |
| <b>LBC</b> | walnut on ash            | +\$0 |
| <b>LBD</b> | dark brown walnut        | +\$0 |
| <b>LBE</b> | medium red walnut        | +\$0 |

|            |                            |      |
|------------|----------------------------|------|
| <b>LBF</b> | neutral twill              | +\$0 |
| <b>LBG</b> | sarum twill                | +\$0 |
| <b>LBH</b> | earthen twill              | +\$0 |
| <b>LBJ</b> | graphite twill             | +\$0 |
| <b>LBK</b> | pewter mesh                | +\$0 |
| <b>LBL</b> | steel mesh                 | +\$0 |
| <b>LBM</b> | crisp linen                | +\$0 |
| <b>LBN</b> | classic linen              | +\$0 |
| <b>LBP</b> | casual linen               | +\$0 |
| <b>LBQ</b> | white twill                | +\$0 |
| <b>LG</b>  | light grey (discontinuing) | +\$0 |
| <b>LM</b>  | mahogany                   | +\$0 |
| <b>LT</b>  | light tone                 | +\$0 |
| <b>LU</b>  | soft white                 | +\$0 |
| <b>MT</b>  | medium tone                | +\$0 |
| <b>OG</b>  | honey maple                | +\$0 |
| <b>WL</b>  | sandstone                  | +\$0 |
| <b>WN</b>  | warm grey neutral          | +\$0 |
| <b>X1</b>  | chalk white                | +\$0 |

Top/Edge Finish: Wood Veneer

*For veneer top/veneer edge (W)*

|           |                             |       |
|-----------|-----------------------------|-------|
| <b>2U</b> | light brown walnut <b>A</b> | +\$85 |
| <b>40</b> | dark brown walnut <b>A</b>  | +\$85 |
| <b>ED</b> | aged cherry <b>A</b>        | +\$85 |
| <b>EK</b> | medium red walnut <b>A</b>  | +\$85 |
| <b>ET</b> | clear on ash <b>A</b>       | +\$85 |
| <b>EU</b> | oak on ash <b>A</b>         | +\$85 |
| <b>EV</b> | walnut on ash <b>A</b>      | +\$85 |
| <b>UL</b> | natural maple <b>A</b>      | +\$85 |
| <b>UX</b> | walnut on cherry <b>A</b>   | +\$85 |

Top/Edge Finish: Opaque Formcoat®

*For painted Formcoat® top/edge (P)*

|           |                   |      |
|-----------|-------------------|------|
| <b>8Q</b> | folkstone grey    | +\$0 |
| <b>91</b> | white             | +\$0 |
| <b>CL</b> | cool grey neutral | +\$0 |
| <b>LU</b> | soft white        | +\$0 |
| <b>WL</b> | sandstone         | +\$0 |
| <b>WN</b> | warm grey neutral | +\$0 |

# Round Corner Table *continued*

| Step 7. Edge Finish                            |                     |      |
|--|---------------------|------|
| <i>For laminate top/thermoplastic edge (L)</i> |                     |      |
| <b>76</b>                                      | light brown walnut  | +\$0 |
| <b>8Q</b>                                      | folkstone grey      | +\$0 |
| <b>91</b>                                      | white               | +\$0 |
| <b>98</b>                                      | studio white        | +\$0 |
| <b>CL</b>                                      | cool grey neutral   | +\$0 |
| <b>LA</b>                                      | light ash           | +\$0 |
| <b>LBA</b>                                     | clear on ash        | +\$0 |
| <b>LBU</b>                                     | medium matte walnut | +\$0 |
| <b>LBB</b>                                     | oak on ash          | +\$0 |
| <b>LBC</b>                                     | walnut on ash       | +\$0 |
| <b>LBD</b>                                     | dark brown walnut   | +\$0 |
| <b>LBE</b>                                     | medium red walnut   | +\$0 |
| <b>LBF</b>                                     | neutral twill       | +\$0 |
| <b>LBG</b>                                     | sarum twill         | +\$0 |
| <b>LBH</b>                                     | earthen twill       | +\$0 |
| <b>LBJ</b>                                     | graphite twill      | +\$0 |
| <b>LBK</b>                                     | pewter mesh         | +\$0 |
| <b>LBL</b>                                     | steel mesh          | +\$0 |
| <b>LBM</b>                                     | crisp linen         | +\$0 |
| <b>LBN</b>                                     | classic linen       | +\$0 |
| <b>LBP</b>                                     | casual linen        | +\$0 |
| <b>LBQ</b>                                     | white twill         | +\$0 |
| <b>WL</b>                                      | sandstone           | +\$0 |
| <b>WN</b>                                      | warm grey neutral   | +\$0 |
| <b>HF</b>                                      | inner tone light    | +\$0 |
| <b>HM</b>                                      | natural maple       | +\$0 |
| <b>HP</b>                                      | light anigre        | +\$0 |
| <b>HT</b>                                      | inner tone          | +\$0 |
| <b>HX</b>                                      | aged cherry         | +\$0 |
| <b>HY</b>                                      | walnut on cherry    | +\$0 |
| <b>LU</b>                                      | soft white          | +\$0 |

| Step 8. Leg/Base Finish |                    |        |
|-------------------------|--------------------|--------|
| <b>98</b>               | studio white       | +\$0   |
| <b>8Q</b>               | folkstone grey     | +\$0   |
| <b>91</b>               | white              | +\$0   |
| <b>BU</b>               | black umber        | +\$0   |
| <b>CL</b>               | cool grey neutral  | +\$0   |
| <b>G2</b>               | graphite satin     | +\$0   |
| <b>HF</b>               | inner tone light   | +\$0   |
| <b>LU</b>               | soft white         | +\$0   |
| <b>MT</b>               | medium tone        | +\$0   |
| <b>SG</b>               | slate grey         | +\$0   |
| <b>WL</b>               | sandstone          | +\$0   |
| <b>WN</b>               | warm grey neutral  | +\$0   |
| <b>CN</b>               | metallic champagne | +\$20  |
| <b>EH</b>               | metallic bronze    | +\$20  |
| <b>MS</b>               | metallic silver    | +\$20  |
| <b>CD</b>               | polished aluminum  | +\$110 |

| Step 9. Casters/Glides |         |      |
|------------------------|---------|------|
| <b>20</b>              | casters | +\$0 |
| <b>57</b>              | glides  | +\$0 |

Everywhere™ Standard-Height Tables

## Flip-Top Rectangular Table

DT5AE.  
DT5AS.  
DT5AT.

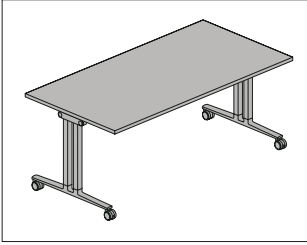

### Product Information

#### Description

This rectangular table comes in multiple edge styles and has a laminate top with thermoplastic edge, laminate top with a thermoplastic backed plywood edge, veneer top and edge, or painted top and edge. It has 2 paddles under the front edge that allow the surface to flip up, minimizing space for storage when not in use. The table has T-legs and is available with casters or glides. The caster option has 2 locking and 2 non-locking casters. Glides have 1/2" leveling range. Shipped knocked down.

#### Notes

Thin edge and eased edge tops not available with 18"-deep surfaces.

Cable grommet options available through Vary Easy Program for round pass through grommet with 2 1/4" hole clearance. Holes are located 3" from rear edge and 6" from end for the L and R options. Covers not provided with painted surface option.

Cutouts available for all Connect™ power and data accessories (see Thrive® Portfolio). Cutouts will be located in the center, laterally, and approximately 3" from the rear edge of surface.

Multiple tables can be nested for storage when surface is flipped up. First table in nest requires 23" of floor space. All additional tables require only 9" of additional space.

Table top overhangs the base by 2 3/4" on each end.

For additional details on available edge options see Appendices.

Only fabric modesty panel (Y1114.) will enable flip top table to fold as intended. It is the recommended modesty panel for use with flip top tables. It is full length and folds out of the way for table storage.

For additional size, edge, finish, and cable management options, see Vary Easy Program in Appendices.

UL listed when used with Connect single circuit electrical product (Y137x.) with T-leg (T) option.

### Dimensions

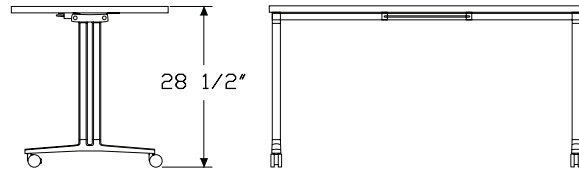
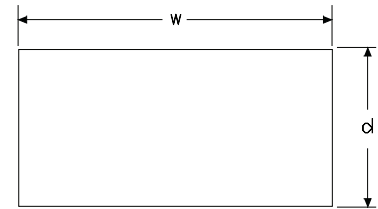



# Flip-Top Rectangular Table *continued*

## Specification Information

### Step 1.

**DT5A**

### Step 2. Edge

- S.** squared-edge
- T.** thin-edge
- E.** eased-edge

### Step 3. Depth

#### *For squared-edge (S.)*

- 18** 18" deep
- 24** 24" deep
- 30** 30" deep

#### *For eased-edge (E.)*

- 24** 24" deep
- 30** 30" deep

#### *For thin-edge (T.)*

- 24** 24" deep
- 30** 30" deep

### Step 4. Width

- 48** 48" wide
- 60** 60" wide
- 72** 72" wide

### Step 5. Surface Material

#### *For squared-edge (S.)*

- L** laminate top/thermoplastic edge
- W** veneer top/veneer edge A
- P** painted Formcoat® top/edge

#### *For thin-edge (T.)*

- W** veneer top/veneer edge A
- P** painted Formcoat® top/edge

#### *For eased-edge (E.)*

- P** painted Formcoat® top/edge

### Step 6. Leg Type

- T** T-leg

## Prices for Steps 1-6.

|                     | LT     | WT     | PT     |
|---------------------|--------|--------|--------|
| <b>DT5AS. 18 48</b> | \$1435 | 1740   | 1651   |
| <b>60</b>           | \$1505 | 1833   | 1732   |
| <b>72</b>           | \$1582 | 1926   | 1818   |
| <b>24 48</b>        | \$1464 | 1776   | 1684   |
| <b>60</b>           | \$1537 | 1871   | 1769   |
| <b>72</b>           | \$1613 | 1965   | 1857   |
| <b>30 48</b>        | \$1552 | 1886   | 1784   |
| <b>60</b>           | \$1692 | 2060   | 1945   |
| <b>72</b>           | \$1776 | 2165   | 2042   |
| <b>DT5AT. 24 48</b> | —      | \$2131 | 1795   |
| <b>60</b>           | —      | \$2244 | 1883   |
| <b>72</b>           | —      | \$2357 | 1977   |
| <b>30 48</b>        | —      | \$2264 | 1901   |
| <b>60</b>           | —      | \$2471 | 2072   |
| <b>72</b>           | —      | \$2598 | 2175   |
| <b>DT5AE. 24 48</b> | —      | —      | \$1795 |
| <b>60</b>           | —      | —      | \$1883 |
| <b>72</b>           | —      | —      | \$1977 |
| <b>30 48</b>        | —      | —      | \$1901 |
| <b>60</b>           | —      | —      | \$2072 |
| <b>72</b>           | —      | —      | \$2175 |

# Flip-Top Rectangular Table *continued*

Everywhere™ Standard-Height Tables

## Step 7.

### Top Finish

#### For laminate top/thermoplastic edge (L)

|            |                     |      |
|------------|---------------------|------|
| <b>76</b>  | light brown walnut  | +\$0 |
| <b>91</b>  | white               | +\$0 |
| <b>98</b>  | studio white        | +\$0 |
| <b>8Q</b>  | folkstone grey      | +\$0 |
| <b>CL</b>  | cool grey neutral   | +\$0 |
| <b>HF</b>  | inner tone light    | +\$0 |
| <b>HM</b>  | natural maple       | +\$0 |
| <b>HP</b>  | light anigre        | +\$0 |
| <b>HT</b>  | inner tone          | +\$0 |
| <b>HX</b>  | aged cherry         | +\$0 |
| <b>HY</b>  | walnut on cherry    | +\$0 |
| <b>LA</b>  | light ash           | +\$0 |
| <b>LBA</b> | clear on ash        | +\$0 |
| <b>LBU</b> | medium matte walnut | +\$0 |
| <b>LBB</b> | oak on ash          | +\$0 |
| <b>LBC</b> | walnut on ash       | +\$0 |
| <b>LBD</b> | dark brown walnut   | +\$0 |
| <b>LBE</b> | medium red walnut   | +\$0 |
| <b>LBF</b> | neutral twill       | +\$0 |
| <b>LBG</b> | sarum twill         | +\$0 |
| <b>LBH</b> | earthen twill       | +\$0 |
| <b>LBJ</b> | graphite twill      | +\$0 |
| <b>LBK</b> | pewter mesh         | +\$0 |
| <b>LBL</b> | steel mesh          | +\$0 |
| <b>LBM</b> | crisp linen         | +\$0 |
| <b>LBN</b> | classic linen       | +\$0 |
| <b>LBP</b> | casual linen        | +\$0 |
| <b>LBQ</b> | white twill         | +\$0 |
| <b>LU</b>  | soft white          | +\$0 |
| <b>WL</b>  | sandstone           | +\$0 |
| <b>WN</b>  | warm grey neutral   | +\$0 |

### Top/Edge Finish: Wood Veneer

#### For veneer top/veneer edge (W)

|           |  |       |
|-----------|--|-------|
| <b>2U</b> | light brown walnut <span style="border: 1px solid black; padding: 0 2px;">A</span> | +\$50 |
| <b>40</b> | dark brown walnut <span style="border: 1px solid black; padding: 0 2px;">A</span>  | +\$50 |
| <b>ED</b> | aged cherry <span style="border: 1px solid black; padding: 0 2px;">A</span>        | +\$50 |
| <b>EK</b> | medium red walnut <span style="border: 1px solid black; padding: 0 2px;">A</span>  | +\$50 |
| <b>ET</b> | clear on ash <span style="border: 1px solid black; padding: 0 2px;">A</span>       | +\$50 |
| <b>EU</b> | oak on ash <span style="border: 1px solid black; padding: 0 2px;">A</span>         | +\$50 |
| <b>EV</b> | walnut on ash <span style="border: 1px solid black; padding: 0 2px;">A</span>      | +\$50 |
| <b>UL</b> | natural maple <span style="border: 1px solid black; padding: 0 2px;">A</span>      | +\$50 |
| <b>UX</b> | walnut on cherry <span style="border: 1px solid black; padding: 0 2px;">A</span>   | +\$50 |

### Top/Edge Finish: Opaque Formcoat®

#### For painted Formcoat® top/edge (P)

|           |                   |      |
|-----------|-------------------|------|
| <b>8Q</b> | folkstone grey    | +\$0 |
| <b>91</b> | white             | +\$0 |
| <b>CL</b> | cool grey neutral | +\$0 |
| <b>LU</b> | soft white        | +\$0 |
| <b>WL</b> | sandstone         | +\$0 |
| <b>WN</b> | warm grey neutral | +\$0 |

### Step 8. Edge Finish

#### For laminate top/thermoplastic edge (L)

|            |                     |      |
|------------|---------------------|------|
| <b>76</b>  | light brown walnut  | +\$0 |
| <b>8Q</b>  | folkstone grey      | +\$0 |
| <b>91</b>  | white               | +\$0 |
| <b>98</b>  | studio white        | +\$0 |
| <b>CL</b>  | cool grey neutral   | +\$0 |
| <b>LA</b>  | light ash           | +\$0 |
| <b>LBA</b> | clear on ash        | +\$0 |
| <b>LBU</b> | medium matte walnut | +\$0 |
| <b>LBB</b> | oak on ash          | +\$0 |
| <b>LBC</b> | walnut on ash       | +\$0 |
| <b>LBD</b> | dark brown walnut   | +\$0 |
| <b>LBE</b> | medium red walnut   | +\$0 |
| <b>LBF</b> | neutral twill       | +\$0 |
| <b>LBG</b> | sarum twill         | +\$0 |
| <b>LBH</b> | earthen twill       | +\$0 |
| <b>LBJ</b> | graphite twill      | +\$0 |
| <b>LBK</b> | pewter mesh         | +\$0 |
| <b>LBL</b> | steel mesh          | +\$0 |
| <b>LBM</b> | crisp linen         | +\$0 |
| <b>LBN</b> | classic linen       | +\$0 |
| <b>LBP</b> | casual linen        | +\$0 |
| <b>LBQ</b> | white twill         | +\$0 |
| <b>WL</b>  | sandstone           | +\$0 |
| <b>WN</b>  | warm grey neutral   | +\$0 |
| <b>HF</b>  | inner tone light    | +\$0 |
| <b>HM</b>  | natural maple       | +\$0 |
| <b>HP</b>  | light anigre        | +\$0 |
| <b>HT</b>  | inner tone          | +\$0 |
| <b>HX</b>  | aged cherry         | +\$0 |
| <b>HY</b>  | walnut on cherry    | +\$0 |
| <b>LU</b>  | soft white          | +\$0 |

## Flip-Top Rectangular Table *continued*

| Step 9. Leg Finish      |   |        |
|-------------------------|---|--------|
| <b>8Q</b>               | folkstone grey                          | +\$0   |
| <b>91</b>               | white                                   | +\$0   |
| <b>98</b>               | studio white <input type="checkbox"/> A | +\$0   |
| <b>BU</b>               | black umber                             | +\$0   |
| <b>CL</b>               | cool grey neutral                       | +\$0   |
| <b>G2</b>               | graphite satin                          | +\$0   |
| <b>HF</b>               | inner tone light                        | +\$0   |
| <b>LU</b>               | soft white                              | +\$0   |
| <b>MT</b>               | medium tone                             | +\$0   |
| <b>SG</b>               | slate grey                              | +\$0   |
| <b>WL</b>               | sandstone                               | +\$0   |
| <b>WN</b>               | warm grey neutral                       | +\$0   |
| <b>CN</b>               | metallic champagne                      | +\$20  |
| <b>EH</b>               | metallic bronze                         | +\$20  |
| <b>MS</b>               | metallic silver                         | +\$20  |
| <b>CD</b>               | polished aluminum                       | +\$110 |
| Step 10. Casters/Glides |   |        |
| <b>20</b>               | casters                                 | +\$0   |
| <b>57</b>               | glides                                  | +\$0   |

# Standard-Height Table Leg

DT2A.

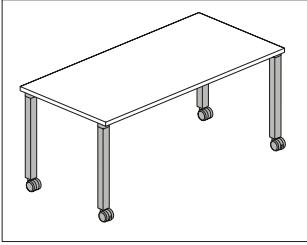

Everywhere™ Standard-Height Table Legs and Bases

## Product Information

### Description

This product is a kit of a full set of table legs with attachment hardware. It has multiple leg options, and is available with casters or glides. The caster option has 2 locking and 2 non-locking casters. Glides have 1/2" leveling range. Shipped knocked down.

### Notes

Height adjustable table legs have a 5" range in 1" increments.

Tabletop must be no more than 30" deep and no less than 24" deep for C and D options. Tabletop must be no more than 36" deep and no less than 18" deep for P, A, and T options.

Tabletops 54" and wider are recommended to have a steel support channel.

Not recommended for tables wider than 84".

Table leg must be located such that the floor glides are not more than 3" from the front and rear sides for table stability.

Tabletop can overhang sides of table base by no more than 15" for tops 60" and wider.

1" long screws provided with base are recommended to attach to tabletop. Ensure mounting surface is no less than 1" thick.

## Dimensions

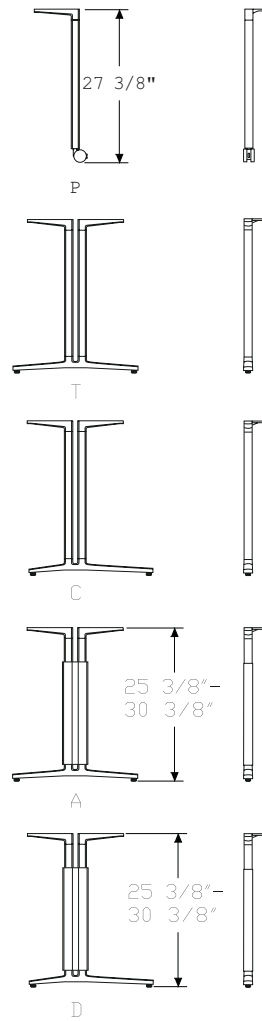

Standard-Height Table Leg *continued*

**Specification Information**

Step 1.

**DT2A.**

Step 2. Depth

|           |          |
|-----------|----------|
| <b>18</b> | 18" deep |
| <b>24</b> | 24" deep |
| <b>30</b> | 30" deep |
| <b>36</b> | 36" deep |

Step 3. Leg Type

*For 18" deep (18) or 36" deep (36)*

|          |                              |
|----------|------------------------------|
| <b>P</b> | post leg                     |
| <b>T</b> | T-leg                        |
| <b>A</b> | T-leg with height adjustment |

*For 24" deep (24) or 30" deep (30)*

|          |                              |
|----------|------------------------------|
| <b>P</b> | post leg                     |
| <b>T</b> | T-leg                        |
| <b>A</b> | T-leg with height adjustment |
| <b>C</b> | C-leg                        |
| <b>D</b> | C-leg with height adjustment |

Step 4. Table Top Surface Material

*For post leg (P)*

|          |                               |
|----------|-------------------------------|
| <b>P</b> | paintable table top           |
| <b>Z</b> | laminated or veneer table top |

*For T-leg (T), T-leg with height adjustment (A), C-leg (C), or C-leg with height adjustment (D)*

|          |  |
|----------|--|
| <b>N</b> | laminated, painted or veneer table top |
|----------|--|

Prices for Steps 1-4.

|              |             | <b>N</b> | <b>P</b> | <b>Z</b> |
|--------------|-------------|----------|----------|----------|
| <b>DT2A.</b> | <b>18 P</b> | —        | \$536    | 536      |
|              | <b>T</b>    | \$679    | —        | —        |
|              | <b>A</b>    | \$1034   | —        | —        |
|              | <b>24 P</b> | —        | \$536    | 536      |
|              | <b>T</b>    | \$702    | —        | —        |
|              | <b>A</b>    | \$1069   | —        | —        |
|              | <b>C</b>    | \$702    | —        | —        |
|              | <b>D</b>    | \$1083   | —        | —        |

|             |        |       |     |
|-------------|--------|-------|-----|
| <b>30 P</b> | —      | \$536 | 536 |
| <b>T</b>    | \$702  | —     | —   |
| <b>A</b>    | \$1069 | —     | —   |
| <b>C</b>    | \$702  | —     | —   |
| <b>D</b>    | \$1083 | —     | —   |
| <b>36 P</b> | —      | \$536 | 536 |
| <b>T</b>    | \$741  | —     | —   |
| <b>A</b>    | \$1107 | —     | —   |

Step 5. Leg Finish

|           |                    |        |
|-----------|--------------------|--------|
| <b>8Q</b> | folkstone grey     | +\$0   |
| <b>91</b> | white              | +\$0   |
| <b>98</b> | studio white       | +\$0   |
| <b>BU</b> | black umber        | +\$0   |
| <b>CL</b> | cool grey neutral  | +\$0   |
| <b>G2</b> | graphite satin     | +\$0   |
| <b>HF</b> | inner tone light   | +\$0   |
| <b>LU</b> | soft white         | +\$0   |
| <b>MT</b> | medium tone        | +\$0   |
| <b>SG</b> | slate grey         | +\$0   |
| <b>WL</b> | sandstone          | +\$0   |
| <b>WN</b> | warm grey neutral  | +\$0   |
| <b>CN</b> | metallic champagne | +\$20  |
| <b>EH</b> | metallic bronze    | +\$20  |
| <b>MS</b> | metallic silver    | +\$20  |
| <b>CD</b> | polished aluminum  | +\$110 |

Step 6. Casters/Glides

|           |         |      |
|-----------|---------|------|
| <b>20</b> | casters | +\$0 |
| <b>57</b> | glides  | +\$0 |

# Standard-Height Table Base

DT2B.

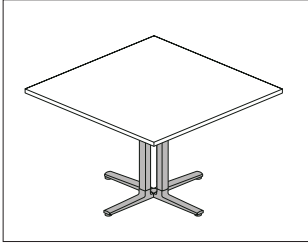

Everywhere™ Standard-Height Table Legs and Bases

### Product Information

#### Description

This product is a kit of a full set of center column table legs with attachment hardware. It has either single column S or 4 column X leg options, and is available with casters or glides. The caster option has 2 locking and 2 non-locking casters. Glides have 1/2" leveling range. Shipped knocked down.

#### Notes

Tabletop must be no more than 42" deep and no less than 30" deep for X base.

Tabletop must be no more than 36" deep and no less than 24" deep for S base.

Table base to be centered side-to-side and left-to-right under tabletop.

Tabletop can over hang sides of table base by no more than 15" for tops 60" and wider.

1" long screws provided with base are recommended to attach to tabletop. Ensure mounting surface is no less than 1" thick.

#### Dimensions

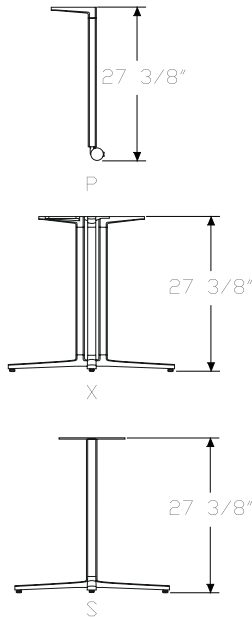

### Specification Information

#### Step 1.

**DT2B.**

#### Step 2. Leg/Base Type

- X** 4-column base
- S** single-column base

#### Prices for Steps 1-2.

|                |       |
|----------------|-------|
| <b>DT2B. X</b> | \$749 |
| <b>S</b>       | \$521 |

#### Step 3. Leg/Base Finish

|           |  |        |
|-----------|--|--------|
| <b>8Q</b> | folkstone grey   | +\$0   |
| <b>91</b> | white  | +\$0   |
| <b>98</b> | studio white <span style="border: 1px solid black; padding: 0 2px;">A</span> | +\$0   |
| <b>BU</b> | black umber  | +\$0   |
| <b>CL</b> | cool grey neutral  | +\$0   |
| <b>G2</b> | graphite satin   | +\$0   |
| <b>HF</b> | inner tone light   | +\$0   |
| <b>LU</b> | soft white   | +\$0   |
| <b>MT</b> | medium tone  | +\$0   |
| <b>SG</b> | slate grey   | +\$0   |
| <b>WL</b> | sandstone  | +\$0   |
| <b>WN</b> | warm grey neutral  | +\$0   |
| <b>CN</b> | metallic champagne   | +\$20  |
| <b>EH</b> | metallic bronze  | +\$20  |
| <b>MS</b> | metallic silver  | +\$20  |
| <b>CD</b> | polished aluminum  | +\$110 |

#### Step 4. Casters/Glides

|           |         |      |
|-----------|---------|------|
| <b>20</b> | casters | +\$0 |
| <b>57</b> | glides  | +\$0 |

# Standing-Height Square Table

DT3BE.  
DT3BS.  
DT3BT.

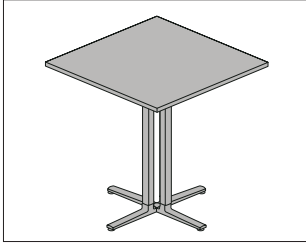

### Product Information

#### Description

This 42"-high, square table comes in multiple edge styles and has a laminate top with thermoplastic edge, laminate top with a thermoplastic backed plywood edge, veneer top and edge, or painted top and edge. The base has glides with 1/2" leveling range. Shipped knocked down.

#### Notes

For additional details on available edge options see Appendices.

For additional size, edge, and finish options, see Vary Easy Program in Appendices.

#### Dimensions

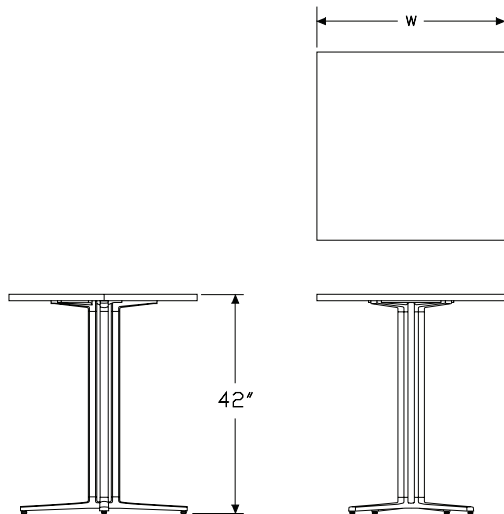

### Specification Information

#### Step 1.

**DT3B**

#### Step 2. Edge

- S.** squared-edge
- T.** thin-edge
- E.** eased-edge

#### Step 3. Depth/Width

- 3030** 30" deep x 30" wide
- 3636** 36" deep x 36" wide

#### Step 4. Surface Material

##### For squared-edge (S.)

- L** laminate top/thermoplastic edge
- W** veneer top/veneer edge **A**
- P** painted Formcoat® top/edge

##### For thin-edge (T.)

- W** veneer top/veneer edge **A**
- P** painted Formcoat® top/edge

##### For eased-edge (E.)

- P** painted Formcoat® top/edge

#### Step 5. Base Type

- X** 4-column base

#### Prices for Steps 1-5.

|                      | <b>X</b> |
|----------------------|----------|
| <b>DT3BS. 3030 L</b> | \$914    |
| <b>W</b>             | \$1086   |
| <b>P</b>             | \$1052   |
| <b>3636 L</b>        | \$1096   |
| <b>W</b>             | \$1314   |
| <b>P</b>             | \$1262   |
|                      | <b>X</b> |
| <b>DT3BT. 3030 W</b> | \$1303   |
| <b>P</b>             | \$1120   |
| <b>3636 W</b>        | \$1575   |
| <b>P</b>             | \$1344   |
|                      | <b>X</b> |
| <b>DT3BE. 3030 P</b> | \$1120   |

# Standing-Height Square Table

continued

Everywhere™ Standing-Height Tables

3636 P \$1344

Step 6.

Top Finish

For laminate top/thermoplastic edge (L)

|            |                     |      |
|------------|---------------------|------|
| <b>76</b>  | light brown walnut  | +\$0 |
| <b>91</b>  | white               | +\$0 |
| <b>98</b>  | studio white        | +\$0 |
| <b>8Q</b>  | folkstone grey      | +\$0 |
| <b>CL</b>  | cool grey neutral   | +\$0 |
| <b>HF</b>  | inner tone light    | +\$0 |
| <b>HM</b>  | natural maple       | +\$0 |
| <b>HP</b>  | light anigre        | +\$0 |
| <b>HT</b>  | inner tone          | +\$0 |
| <b>HX</b>  | aged cherry         | +\$0 |
| <b>HY</b>  | walnut on cherry    | +\$0 |
| <b>LA</b>  | light ash           | +\$0 |
| <b>LBA</b> | clear on ash        | +\$0 |
| <b>LBU</b> | medium matte walnut | +\$0 |
| <b>LBB</b> | oak on ash          | +\$0 |
| <b>LBC</b> | walnut on ash       | +\$0 |
| <b>LBD</b> | dark brown walnut   | +\$0 |
| <b>LBE</b> | medium red walnut   | +\$0 |
| <b>LBF</b> | neutral twill       | +\$0 |
| <b>LBG</b> | sarum twill         | +\$0 |
| <b>LBH</b> | earthen twill       | +\$0 |
| <b>LBJ</b> | graphite twill      | +\$0 |
| <b>LBK</b> | pewter mesh         | +\$0 |
| <b>LBL</b> | steel mesh          | +\$0 |
| <b>LBM</b> | crisp linen         | +\$0 |
| <b>LBN</b> | classic linen       | +\$0 |
| <b>LBP</b> | casual linen        | +\$0 |
| <b>LBQ</b> | white twill         | +\$0 |
| <b>LU</b>  | soft white          | +\$0 |
| <b>WL</b>  | sandstone           | +\$0 |
| <b>WN</b>  | warm grey neutral   | +\$0 |

Top/Edge Finish: Wood Veneer

For veneer top/veneer edge (W)

|           |   |       |
|-----------|---|-------|
| <b>2U</b> | light brown walnut <input type="checkbox"/> A | +\$50 |
| <b>40</b> | dark brown walnut <input type="checkbox"/> A  | +\$50 |
| <b>ED</b> | aged cherry <input type="checkbox"/> A        | +\$50 |
| <b>EK</b> | medium red walnut <input type="checkbox"/> A  | +\$50 |
| <b>ET</b> | clear on ash <input type="checkbox"/> A       | +\$50 |
| <b>EU</b> | oak on ash <input type="checkbox"/> A         | +\$50 |
| <b>EV</b> | walnut on ash <input type="checkbox"/> A      | +\$50 |
| <b>UL</b> | natural maple <input type="checkbox"/> A      | +\$50 |
| <b>UX</b> | walnut on cherry <input type="checkbox"/> A   | +\$50 |

Top/Edge Finish: Opaque Formcoat®

For painted Formcoat® top/edge (P)

|           |                   |      |
|-----------|-------------------|------|
| <b>8Q</b> | folkstone grey    | +\$0 |
| <b>91</b> | white             | +\$0 |
| <b>CL</b> | cool grey neutral | +\$0 |
| <b>LU</b> | soft white        | +\$0 |
| <b>WL</b> | sandstone         | +\$0 |
| <b>WN</b> | warm grey neutral | +\$0 |



# Standing-Height Square Table

continued

| Step 7. Edge Finish                            |                     |      |
|--|---------------------|------|
| <i>For laminate top/thermoplastic edge (L)</i> |                     |      |
| <b>76</b>                                      | light brown walnut  | +\$0 |
| <b>8Q</b>                                      | folkstone grey      | +\$0 |
| <b>91</b>                                      | white               | +\$0 |
| <b>98</b>                                      | studio white        | +\$0 |
| <b>CL</b>                                      | cool grey neutral   | +\$0 |
| <b>LA</b>                                      | light ash           | +\$0 |
| <b>LBA</b>                                     | clear on ash        | +\$0 |
| <b>LBU</b>                                     | medium matte walnut | +\$0 |
| <b>LBB</b>                                     | oak on ash          | +\$0 |
| <b>LBC</b>                                     | walnut on ash       | +\$0 |
| <b>LBD</b>                                     | dark brown walnut   | +\$0 |
| <b>LBE</b>                                     | medium red walnut   | +\$0 |
| <b>LBF</b>                                     | neutral twill       | +\$0 |
| <b>LBG</b>                                     | sarum twill         | +\$0 |
| <b>LBH</b>                                     | earthen twill       | +\$0 |
| <b>LBJ</b>                                     | graphite twill      | +\$0 |
| <b>LBK</b>                                     | pewter mesh         | +\$0 |
| <b>LBL</b>                                     | steel mesh          | +\$0 |
| <b>LBM</b>                                     | crisp linen         | +\$0 |
| <b>LBN</b>                                     | classic linen       | +\$0 |
| <b>LBP</b>                                     | casual linen        | +\$0 |
| <b>LBQ</b>                                     | white twill         | +\$0 |
| <b>WL</b>                                      | sandstone           | +\$0 |
| <b>WN</b>                                      | warm grey neutral   | +\$0 |
| <b>HF</b>                                      | inner tone light    | +\$0 |
| <b>HM</b>                                      | natural maple       | +\$0 |
| <b>HP</b>                                      | light anigre        | +\$0 |
| <b>HT</b>                                      | inner tone          | +\$0 |
| <b>HX</b>                                      | aged cherry         | +\$0 |
| <b>HY</b>                                      | walnut on cherry    | +\$0 |
| <b>LU</b>                                      | soft white          | +\$0 |

| Step 8. Base Finish |  |        |
|---------------------|--|--------|
| <b>8Q</b>           | folkstone grey   | +\$0   |
| <b>91</b>           | white  | +\$0   |
| <b>98</b>           | studio white <span style="border: 1px solid black; padding: 0 2px;">A</span> | +\$0   |
| <b>BU</b>           | black umber  | +\$0   |
| <b>CD</b>           | polished aluminum  | +\$110 |
| <b>CL</b>           | cool grey neutral  | +\$0   |
| <b>CN</b>           | metallic champagne   | +\$20  |
| <b>EH</b>           | metallic bronze  | +\$20  |
| <b>G2</b>           | graphite satin   | +\$0   |
| <b>HF</b>           | inner tone light   | +\$0   |
| <b>LU</b>           | soft white   | +\$0   |
| <b>MS</b>           | metallic silver  | +\$20  |
| <b>MT</b>           | medium tone  | +\$0   |
| <b>SG</b>           | slate grey   | +\$0   |
| <b>WL</b>           | sandstone  | +\$0   |
| <b>WN</b>           | warm grey neutral  | +\$0   |

Everywhere™ Standing-Height Tables

# Standing-Height Round Table

DT3CE.  
DT3CS.  
DT3CT.



Everywhere™ Standing-Height Tables

### Product Information

**Description**  
This 42"-high, round table comes in multiple edge styles and has a laminate top with thermoplastic edge, veneer top and edge, or painted top and edge. The base has glides with 1/2" leveling range. Shipped knocked down.

### Notes

For additional details on available edge options see Appendices.  
For additional size, edge, and finish options, see Vary Easy Program in Appendices.

### Dimensions

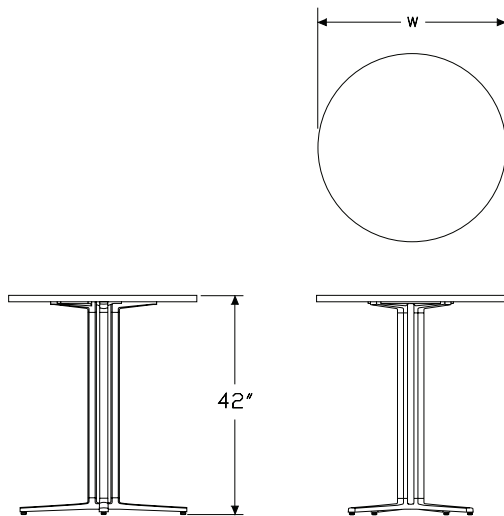

### Specification Information

#### Step 1.

**DT3C**

#### Step 2. Edge

- S.** squared-edge
- T.** thin-edge
- E.** eased-edge

#### Step 3. Diameter

- 30** 30" diameter
- 36** 36" diameter

#### Step 4. Surface Material

##### For squared-edge (S.)

- L** laminate top/thermoplastic edge
- W** veneer top/veneer edge **A**
- P** painted Formcoat® top/edge

##### For thin-edge (T.)

- W** veneer top/veneer edge **A**
- P** painted Formcoat® top/edge

##### For eased-edge (E.)

- P** painted Formcoat® top/edge

#### Step 5. Base Type

- X** 4-column base

#### Prices for Steps 1-5.

|                    | <b>X</b> |
|--------------------|----------|
| <b>DT3CS. 30 L</b> | \$1052   |
| <b>W</b>           | \$1248   |
| <b>P</b>           | \$1210   |
| <b>36 L</b>        | \$1261   |
| <b>W</b>           | \$1510   |
| <b>P</b>           | \$1451   |
|                    | <b>X</b> |
| <b>DT3CT. 30 W</b> | \$1498   |
| <b>P</b>           | \$1288   |
| <b>36 W</b>        | \$1813   |
| <b>P</b>           | \$1544   |
|                    | <b>X</b> |
| <b>DT3CE. 30 P</b> | \$1288   |

# Standing-Height Round Table

continued

**36 P** \$1544

Step 6.

Top Finish

*For laminate top/thermoplastic edge (L)*

|            |                     |      |
|------------|---------------------|------|
| <b>76</b>  | light brown walnut  | +\$0 |
| <b>91</b>  | white               | +\$0 |
| <b>98</b>  | studio white        | +\$0 |
| <b>8Q</b>  | folkstone grey      | +\$0 |
| <b>CL</b>  | cool grey neutral   | +\$0 |
| <b>HF</b>  | inner tone light    | +\$0 |
| <b>HM</b>  | natural maple       | +\$0 |
| <b>HP</b>  | light anigre        | +\$0 |
| <b>HT</b>  | inner tone          | +\$0 |
| <b>HX</b>  | aged cherry         | +\$0 |
| <b>HY</b>  | walnut on cherry    | +\$0 |
| <b>LA</b>  | light ash           | +\$0 |
| <b>LBA</b> | clear on ash        | +\$0 |
| <b>LBU</b> | medium matte walnut | +\$0 |
| <b>LBB</b> | oak on ash          | +\$0 |
| <b>LBC</b> | walnut on ash       | +\$0 |
| <b>LBD</b> | dark brown walnut   | +\$0 |
| <b>LBE</b> | medium red walnut   | +\$0 |
| <b>LBF</b> | neutral twill       | +\$0 |
| <b>LBG</b> | sarum twill         | +\$0 |
| <b>LBH</b> | earthen twill       | +\$0 |
| <b>LBJ</b> | graphite twill      | +\$0 |
| <b>LBK</b> | pewter mesh         | +\$0 |
| <b>LBL</b> | steel mesh          | +\$0 |
| <b>LBM</b> | crisp linen         | +\$0 |
| <b>LBN</b> | classic linen       | +\$0 |
| <b>LBP</b> | casual linen        | +\$0 |
| <b>LBQ</b> | white twill         | +\$0 |
| <b>LU</b>  | soft white          | +\$0 |
| <b>WL</b>  | sandstone           | +\$0 |
| <b>WN</b>  | warm grey neutral   | +\$0 |

Top/Edge Finish: Wood Veneer

*For veneer top/veneer edge (W)*

|           |   |       |
|-----------|---|-------|
| <b>2U</b> | light brown walnut <input type="checkbox"/> A | +\$50 |
| <b>40</b> | dark brown walnut <input type="checkbox"/> A  | +\$50 |
| <b>ED</b> | aged cherry <input type="checkbox"/> A        | +\$50 |
| <b>EK</b> | medium red walnut <input type="checkbox"/> A  | +\$50 |
| <b>ET</b> | clear on ash <input type="checkbox"/> A       | +\$50 |
| <b>EU</b> | oak on ash <input type="checkbox"/> A         | +\$50 |
| <b>EV</b> | walnut on ash <input type="checkbox"/> A      | +\$50 |
| <b>UL</b> | natural maple <input type="checkbox"/> A      | +\$50 |
| <b>UX</b> | walnut on cherry <input type="checkbox"/> A   | +\$50 |

Top/Edge Finish: Opaque Formcoat®

*For painted Formcoat® top/edge (P)*

|           |                   |      |
|-----------|-------------------|------|
| <b>8Q</b> | folkstone grey    | +\$0 |
| <b>91</b> | white             | +\$0 |
| <b>CL</b> | cool grey neutral | +\$0 |
| <b>LU</b> | soft white        | +\$0 |
| <b>WL</b> | sandstone         | +\$0 |
| <b>WN</b> | warm grey neutral | +\$0 |

Everywhere™ Standing-Height Tables

# Standing-Height Round Table

continued

Everywhere™ Standing-Height Tables

| Step 7. Edge Finish                            |                     |      |
|--|---------------------|------|
| <i>For laminate top/thermoplastic edge (L)</i> |                     |      |
| <b>76</b>                                      | light brown walnut  | +\$0 |
| <b>8Q</b>                                      | folkstone grey      | +\$0 |
| <b>91</b>                                      | white               | +\$0 |
| <b>98</b>                                      | studio white        | +\$0 |
| <b>CL</b>                                      | cool grey neutral   | +\$0 |
| <b>LA</b>                                      | light ash           | +\$0 |
| <b>LBA</b>                                     | clear on ash        | +\$0 |
| <b>LBU</b>                                     | medium matte walnut | +\$0 |
| <b>LBB</b>                                     | oak on ash          | +\$0 |
| <b>LBC</b>                                     | walnut on ash       | +\$0 |
| <b>LBD</b>                                     | dark brown walnut   | +\$0 |
| <b>LBE</b>                                     | medium red walnut   | +\$0 |
| <b>LBF</b>                                     | neutral twill       | +\$0 |
| <b>LBG</b>                                     | sarum twill         | +\$0 |
| <b>LBH</b>                                     | earthen twill       | +\$0 |
| <b>LBJ</b>                                     | graphite twill      | +\$0 |
| <b>LBK</b>                                     | pewter mesh         | +\$0 |
| <b>LBL</b>                                     | steel mesh          | +\$0 |
| <b>LBM</b>                                     | crisp linen         | +\$0 |
| <b>LBN</b>                                     | classic linen       | +\$0 |
| <b>LBP</b>                                     | casual linen        | +\$0 |
| <b>LBQ</b>                                     | white twill         | +\$0 |
| <b>WL</b>                                      | sandstone           | +\$0 |
| <b>WN</b>                                      | warm grey neutral   | +\$0 |
| <b>HF</b>                                      | inner tone light    | +\$0 |
| <b>HM</b>                                      | natural maple       | +\$0 |
| <b>HP</b>                                      | light anigre        | +\$0 |
| <b>HT</b>                                      | inner tone          | +\$0 |
| <b>HX</b>                                      | aged cherry         | +\$0 |
| <b>HY</b>                                      | walnut on cherry    | +\$0 |
| <b>LU</b>                                      | soft white          | +\$0 |

| Step 8. Base Finish |  |        |
|---------------------|--|--------|
| <b>8Q</b>           | folkstone grey   | +\$0   |
| <b>91</b>           | white  | +\$0   |
| <b>98</b>           | studio white <span style="border: 1px solid black; padding: 0 2px;">A</span> | +\$0   |
| <b>BU</b>           | black umber  | +\$0   |
| <b>CL</b>           | cool grey neutral  | +\$0   |
| <b>G2</b>           | graphite satin   | +\$0   |
| <b>HF</b>           | inner tone light   | +\$0   |
| <b>LU</b>           | soft white   | +\$0   |
| <b>MT</b>           | medium tone  | +\$0   |
| <b>SG</b>           | slate grey   | +\$0   |
| <b>WL</b>           | sandstone  | +\$0   |
| <b>WN</b>           | warm grey neutral  | +\$0   |
| <b>CN</b>           | metallic champagne   | +\$20  |
| <b>EH</b>           | metallic bronze  | +\$20  |
| <b>MS</b>           | metallic silver  | +\$20  |
| <b>CD</b>           | polished aluminum  | +\$110 |

# Occasional Table, Square

DT4BS.  
DT4BT.

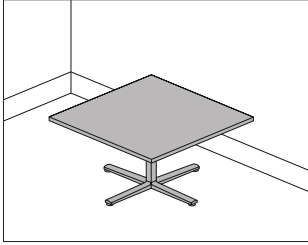

### Product Information

#### Description

This 16"-high, square table comes in multiple edge styles and has a laminate top with thermoplastic edge, laminate top with a thermoplastic backed plywood edge, veneer top and edge, or painted top and edge. The base has glides with 1/2" leveling range. Shipped knocked down.

#### Notes

For additional details on available edge options see Appendices.

For additional size, edge, and finish options, see Vary Easy Program in Appendices.

#### Dimensions

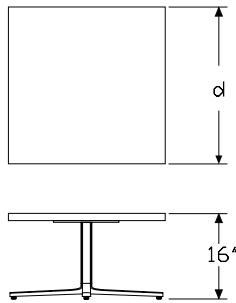

### Specification Information

#### Step 1.

**DT4B**

#### Step 2. Edge

- S.** squared-edge
- T.** thin-edge

#### Step 3. Depth/Width

- 2424** 24" deep x 24" wide
- 3030** 30" deep x 30" wide
- 3636** 36" deep x 36" wide

#### Step 4. Surface Material

##### For squared-edge (S.)

- L** laminate top/thermoplastic edge
- W** veneer top/veneer edge **A**
- P** painted Formcoat® top/edge

##### For thin-edge (T.)

- W** veneer top/veneer edge **A**
- P** painted Formcoat® top/edge

#### Step 5. Base Type

- S** single-column base

#### Prices for Steps 1-5.

|                      | <b>S</b> |
|----------------------|----------|
| <b>DT4BS. 2424 L</b> | \$698    |
| <b>W</b>             | \$815    |
| <b>P</b>             | \$803    |
| <b>3030 L</b>        | \$837    |
| <b>W</b>             | \$988    |
| <b>P</b>             | \$963    |
| <b>3636 L</b>        | \$963    |
| <b>W</b>             | \$1145   |
| <b>P</b>             | \$1107   |
|                      | <b>S</b> |
| <b>DT4BT. 2424 W</b> | \$978    |
| <b>P</b>             | \$855    |
| <b>3030 W</b>        | \$1187   |
| <b>P</b>             | \$1024   |
| <b>3636 W</b>        | \$1376   |
| <b>P</b>             | \$1179   |

# Occasional Table, Square *continued*

Step 6.

Top Finish

*For laminate top/thermoplastic edge (L)*

|            |                          |      |
|------------|--------------------------|------|
| <b>28</b>  | canyon                   | +\$0 |
| <b>29</b>  | misted                   | +\$0 |
| <b>38</b>  | twilight                 | +\$0 |
| <b>39</b>  | desert                   | +\$0 |
| <b>76</b>  | light brown walnut       | +\$0 |
| <b>91</b>  | white                    | +\$0 |
| <b>98</b>  | studio white             | +\$0 |
| <b>1X</b>  | vanilla                  | +\$0 |
| <b>2X</b>  | wheat                    | +\$0 |
| <b>3X</b>  | celery                   | +\$0 |
| <b>4X</b>  | coriander                | +\$0 |
| <b>5X</b>  | chamomile                | +\$0 |
| <b>6X</b>  | cinnamon                 | +\$0 |
| <b>7X</b>  | cardamom                 | +\$0 |
| <b>8X</b>  | kale                     | +\$0 |
| <b>8Q</b>  | folkstone grey           | +\$0 |
| <b>CL</b>  | cool grey neutral        | +\$0 |
| <b>HF</b>  | inner tone light         | +\$0 |
| <b>HM</b>  | natural maple            | +\$0 |
| <b>HP</b>  | light anigre             | +\$0 |
| <b>HT</b>  | inner tone               | +\$0 |
| <b>HX</b>  | aged cherry              | +\$0 |
| <b>HY</b>  | walnut on cherry         | +\$0 |
| <b>J4</b>  | frosted light grey       | +\$0 |
| <b>J5</b>  | frosted inner tone light | +\$0 |
| <b>J7</b>  | frosted medium tone      | +\$0 |
| <b>LA</b>  | light ash                | +\$0 |
| <b>LBA</b> | clear on ash             | +\$0 |
| <b>LBU</b> | medium matte walnut      | +\$0 |
| <b>LBB</b> | oak on ash               | +\$0 |
| <b>LBC</b> | walnut on ash            | +\$0 |
| <b>LBD</b> | dark brown walnut        | +\$0 |
| <b>LBE</b> | medium red walnut        | +\$0 |
| <b>LBF</b> | neutral twill            | +\$0 |
| <b>LBG</b> | sarum twill              | +\$0 |
| <b>LBH</b> | earthen twill            | +\$0 |
| <b>LBJ</b> | graphite twill           | +\$0 |
| <b>LBK</b> | pewter mesh              | +\$0 |
| <b>LBL</b> | steel mesh               | +\$0 |
| <b>LBM</b> | crisp linen              | +\$0 |
| <b>LBN</b> | classic linen            | +\$0 |
| <b>LBP</b> | casual linen             | +\$0 |
| <b>LBQ</b> | white twill              | +\$0 |

|           |                            |      |
|-----------|----------------------------|------|
| <b>LG</b> | light grey (discontinuing) | +\$0 |
| <b>LM</b> | mahogany                   | +\$0 |
| <b>LT</b> | light tone                 | +\$0 |
| <b>LU</b> | soft white                 | +\$0 |
| <b>MT</b> | medium tone                | +\$0 |
| <b>OG</b> | honey maple                | +\$0 |
| <b>WL</b> | sandstone                  | +\$0 |
| <b>WN</b> | warm grey neutral          | +\$0 |
| <b>X1</b> | chalk white                | +\$0 |

Top/Edge Finish: Wood Veneer

*For veneer top/veneer edge (W)*

|           |  |       |
|-----------|--|-------|
| <b>2U</b> | light brown walnut <span style="border: 1px solid black; padding: 0 2px;">A</span> | +\$50 |
| <b>40</b> | dark brown walnut <span style="border: 1px solid black; padding: 0 2px;">A</span>  | +\$50 |
| <b>ED</b> | aged cherry <span style="border: 1px solid black; padding: 0 2px;">A</span>        | +\$50 |
| <b>EK</b> | medium red walnut <span style="border: 1px solid black; padding: 0 2px;">A</span>  | +\$50 |
| <b>ET</b> | clear on ash <span style="border: 1px solid black; padding: 0 2px;">A</span>       | +\$50 |
| <b>EU</b> | oak on ash <span style="border: 1px solid black; padding: 0 2px;">A</span>         | +\$50 |
| <b>EV</b> | walnut on ash <span style="border: 1px solid black; padding: 0 2px;">A</span>      | +\$50 |
| <b>UL</b> | natural maple <span style="border: 1px solid black; padding: 0 2px;">A</span>      | +\$50 |
| <b>UX</b> | walnut on cherry <span style="border: 1px solid black; padding: 0 2px;">A</span>   | +\$50 |

Top/Edge Finish: Opaque Formcoat®

*For painted Formcoat® top/edge (P)*

|           |                   |      |
|-----------|-------------------|------|
| <b>8Q</b> | folkstone grey    | +\$0 |
| <b>91</b> | white             | +\$0 |
| <b>CL</b> | cool grey neutral | +\$0 |
| <b>LU</b> | soft white        | +\$0 |
| <b>WL</b> | sandstone         | +\$0 |
| <b>WN</b> | warm grey neutral | +\$0 |

## Occasional Table, Square *continued*

### Step 7. Edge Finish

*For laminate top/thermoplastic edge (L)*

|            |                     |      |
|------------|---------------------|------|
| <b>76</b>  | light brown walnut  | +\$0 |
| <b>8Q</b>  | folkstone grey      | +\$0 |
| <b>91</b>  | white               | +\$0 |
| <b>98</b>  | studio white        | +\$0 |
| <b>CL</b>  | cool grey neutral   | +\$0 |
| <b>HF</b>  | inner tone light    | +\$0 |
| <b>HM</b>  | natural maple       | +\$0 |
| <b>HP</b>  | light anigre        | +\$0 |
| <b>HT</b>  | inner tone          | +\$0 |
| <b>HX</b>  | aged cherry         | +\$0 |
| <b>HY</b>  | walnut on cherry    | +\$0 |
| <b>LA</b>  | light ash           | +\$0 |
| <b>LBA</b> | clear on ash        | +\$0 |
| <b>LBB</b> | oak on ash          | +\$0 |
| <b>LBC</b> | walnut on ash       | +\$0 |
| <b>LBD</b> | dark brown walnut   | +\$0 |
| <b>LBE</b> | medium red walnut   | +\$0 |
| <b>LBF</b> | neutral twill       | +\$0 |
| <b>LBG</b> | sarum twill         | +\$0 |
| <b>LBH</b> | earthen twill       | +\$0 |
| <b>LBJ</b> | graphite twill      | +\$0 |
| <b>LBK</b> | pewter mesh         | +\$0 |
| <b>LBL</b> | steel mesh          | +\$0 |
| <b>LBM</b> | crisp linen         | +\$0 |
| <b>LBN</b> | classic linen       | +\$0 |
| <b>LBP</b> | casual linen        | +\$0 |
| <b>LBQ</b> | white twill         | +\$0 |
| <b>LBU</b> | medium matte walnut | +\$0 |
| <b>LU</b>  | soft white          | +\$0 |
| <b>WL</b>  | sandstone           | +\$0 |
| <b>WN</b>  | warm grey neutral   | +\$0 |

### Step 8. Base Finish

|           |  |        |
|-----------|--|--------|
| <b>8Q</b> | folkstone grey   | +\$0   |
| <b>91</b> | white  | +\$0   |
| <b>98</b> | studio white <span style="border: 1px solid black; padding: 0 2px;">A</span> | +\$0   |
| <b>BU</b> | black umber  | +\$0   |
| <b>CD</b> | polished aluminum  | +\$110 |
| <b>CL</b> | cool grey neutral  | +\$0   |
| <b>CN</b> | metallic champagne   | +\$20  |
| <b>EH</b> | metallic bronze  | +\$20  |
| <b>G2</b> | graphite satin   | +\$0   |
| <b>HF</b> | inner tone light   | +\$0   |
| <b>LU</b> | soft white   | +\$0   |
| <b>MS</b> | metallic silver  | +\$20  |
| <b>MT</b> | medium tone  | +\$0   |
| <b>SG</b> | slate grey   | +\$0   |
| <b>WL</b> | sandstone  | +\$0   |
| <b>WN</b> | warm grey neutral  | +\$0   |

# Occasional Table, Round

DT4CS.  
DT4CT.

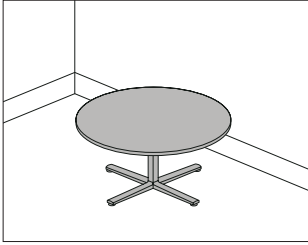

### Product Information

#### Description

This 16"-high, round table comes in multiple edge styles and has a laminate top with thermoplastic edge, veneer top and edge, or painted top and edge. The base has glides with 1/2" leveling range. Shipped knocked down.

#### Notes

For additional details on available edge options see Appendices.

For additional size, edge, and finish options, see Vary Easy Program in Appendices.

#### Dimensions

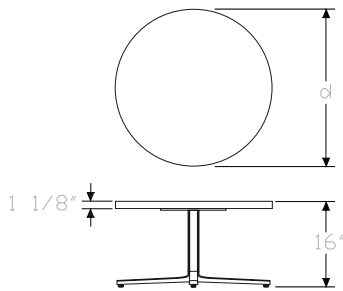

Everywhere™ Occasional Tables

### Specification Information

#### Step 1.

#### DT4C

#### Step 2. Edge

- S. squared-edge
- T. thin-edge

#### Step 3. Diameter

- 30 30" diameter
- 36 36" diameter

#### Step 4. Surface Material

#### For squared-edge (S.)

- L laminate top/thermoplastic edge
- W veneer top/veneer edge A
- P painted Formcoat® top/edge

#### For thin-edge (T.)

- W veneer top/veneer edge A
- P painted Formcoat® top/edge

#### Step 5. Base Type

- S single-column base

#### Prices for Steps 1-5.

|                    | <b>S</b> |
|--------------------|----------|
| <b>DT4CS. 30 L</b> | \$961    |
| <b>W</b>           | \$1137   |
| <b>P</b>           | \$1106   |
| <b>36 L</b>        | \$1106   |
| <b>W</b>           | \$1317   |
| <b>P</b>           | \$1273   |

|                    | <b>S</b> |
|--------------------|----------|
| <b>DT4CT. 30 W</b> | \$1363   |
| <b>P</b>           | \$1178   |
| <b>36 W</b>        | \$1581   |
| <b>P</b>           | \$1355   |

#### Step 6.

#### Top Finish

#### For laminate top/thermoplastic edge (L)

- 28 canyon +\$0
- 29 misted +\$0



Occasional Table, Round *continued*

|            |                            |      |
|------------|----------------------------|------|
| <b>38</b>  | twilight                   | +\$0 |
| <b>39</b>  | desert                     | +\$0 |
| <b>76</b>  | light brown walnut         | +\$0 |
| <b>91</b>  | white                      | +\$0 |
| <b>98</b>  | studio white               | +\$0 |
| <b>1X</b>  | vanilla                    | +\$0 |
| <b>2X</b>  | wheat                      | +\$0 |
| <b>3X</b>  | celery                     | +\$0 |
| <b>4X</b>  | coriander                  | +\$0 |
| <b>5X</b>  | chamomile                  | +\$0 |
| <b>6X</b>  | cinnamon                   | +\$0 |
| <b>7X</b>  | cardamom                   | +\$0 |
| <b>8X</b>  | kale                       | +\$0 |
| <b>8Q</b>  | folkstone grey             | +\$0 |
| <b>CL</b>  | cool grey neutral          | +\$0 |
| <b>HF</b>  | inner tone light           | +\$0 |
| <b>HM</b>  | natural maple              | +\$0 |
| <b>HP</b>  | light anigre               | +\$0 |
| <b>HT</b>  | inner tone                 | +\$0 |
| <b>HX</b>  | aged cherry                | +\$0 |
| <b>HY</b>  | walnut on cherry           | +\$0 |
| <b>J4</b>  | frosted light grey         | +\$0 |
| <b>J5</b>  | frosted inner tone light   | +\$0 |
| <b>J7</b>  | frosted medium tone        | +\$0 |
| <b>LA</b>  | light ash                  | +\$0 |
| <b>LBA</b> | clear on ash               | +\$0 |
| <b>LBU</b> | medium matte walnut        | +\$0 |
| <b>LBB</b> | oak on ash                 | +\$0 |
| <b>LBC</b> | walnut on ash              | +\$0 |
| <b>LBD</b> | dark brown walnut          | +\$0 |
| <b>LBE</b> | medium red walnut          | +\$0 |
| <b>LBF</b> | neutral twill              | +\$0 |
| <b>LBG</b> | sarum twill                | +\$0 |
| <b>LBH</b> | earthen twill              | +\$0 |
| <b>LBJ</b> | graphite twill             | +\$0 |
| <b>LBK</b> | pewter mesh                | +\$0 |
| <b>LBL</b> | steel mesh                 | +\$0 |
| <b>LBM</b> | crisp linen                | +\$0 |
| <b>LBN</b> | classic linen              | +\$0 |
| <b>LBP</b> | casual linen               | +\$0 |
| <b>LBQ</b> | white twill                | +\$0 |
| <b>LG</b>  | light grey (discontinuing) | +\$0 |
| <b>LM</b>  | mahogany                   | +\$0 |
| <b>LT</b>  | light tone                 | +\$0 |
| <b>LU</b>  | soft white                 | +\$0 |
| <b>MT</b>  | medium tone                | +\$0 |
| <b>OG</b>  | honey maple                | +\$0 |

|           |                   |      |
|-----------|-------------------|------|
| <b>WL</b> | sandstone         | +\$0 |
| <b>WN</b> | warm grey neutral | +\$0 |
| <b>X1</b> | chalk white       | +\$0 |

---

Top/Edge Finish: Wood Veneer

*For veneer top/veneer edge (W)*

|           |  |       |
|-----------|--|-------|
| <b>2U</b> | light brown walnut <span style="border: 1px solid black; padding: 0 2px;">A</span> | +\$50 |
| <b>40</b> | dark brown walnut <span style="border: 1px solid black; padding: 0 2px;">A</span>  | +\$50 |
| <b>ED</b> | aged cherry <span style="border: 1px solid black; padding: 0 2px;">A</span>        | +\$50 |
| <b>EK</b> | medium red walnut <span style="border: 1px solid black; padding: 0 2px;">A</span>  | +\$50 |
| <b>ET</b> | clear on ash <span style="border: 1px solid black; padding: 0 2px;">A</span>       | +\$50 |
| <b>EU</b> | oak on ash <span style="border: 1px solid black; padding: 0 2px;">A</span>         | +\$50 |
| <b>EV</b> | walnut on ash <span style="border: 1px solid black; padding: 0 2px;">A</span>      | +\$50 |
| <b>UL</b> | natural maple <span style="border: 1px solid black; padding: 0 2px;">A</span>      | +\$50 |
| <b>UX</b> | walnut on cherry <span style="border: 1px solid black; padding: 0 2px;">A</span>   | +\$50 |

---

Top/Edge Finish: Opaque Formcoat®

*For painted Formcoat® top/edge (P)*

|           |                   |      |
|-----------|-------------------|------|
| <b>8Q</b> | folkstone grey    | +\$0 |
| <b>91</b> | white             | +\$0 |
| <b>CL</b> | cool grey neutral | +\$0 |
| <b>LU</b> | soft white        | +\$0 |
| <b>WL</b> | sandstone         | +\$0 |
| <b>WN</b> | warm grey neutral | +\$0 |

# Occasional Table, Round *continued*

Everywhere™ Occasional Tables

| Step 7. Edge Finish                            |                     |      |
|--|---------------------|------|
| <i>For laminate top/thermoplastic edge (L)</i> |                     |      |
| <b>76</b>                                      | light brown walnut  | +\$0 |
| <b>8Q</b>                                      | folkstone grey      | +\$0 |
| <b>91</b>                                      | white               | +\$0 |
| <b>98</b>                                      | studio white        | +\$0 |
| <b>CL</b>                                      | cool grey neutral   | +\$0 |
| <b>HF</b>                                      | inner tone light    | +\$0 |
| <b>HM</b>                                      | natural maple       | +\$0 |
| <b>HP</b>                                      | light anigre        | +\$0 |
| <b>HT</b>                                      | inner tone          | +\$0 |
| <b>HX</b>                                      | aged cherry         | +\$0 |
| <b>HY</b>                                      | walnut on cherry    | +\$0 |
| <b>LA</b>                                      | light ash           | +\$0 |
| <b>LBA</b>                                     | clear on ash        | +\$0 |
| <b>LBB</b>                                     | oak on ash          | +\$0 |
| <b>LBC</b>                                     | walnut on ash       | +\$0 |
| <b>LBD</b>                                     | dark brown walnut   | +\$0 |
| <b>LBE</b>                                     | medium red walnut   | +\$0 |
| <b>LBF</b>                                     | neutral twill       | +\$0 |
| <b>LBG</b>                                     | sarum twill         | +\$0 |
| <b>LBH</b>                                     | earthen twill       | +\$0 |
| <b>LBJ</b>                                     | graphite twill      | +\$0 |
| <b>LBK</b>                                     | pewter mesh         | +\$0 |
| <b>LBL</b>                                     | steel mesh          | +\$0 |
| <b>LBM</b>                                     | crisp linen         | +\$0 |
| <b>LBN</b>                                     | classic linen       | +\$0 |
| <b>LBP</b>                                     | casual linen        | +\$0 |
| <b>LBQ</b>                                     | white twill         | +\$0 |
| <b>LBU</b>                                     | medium matte walnut | +\$0 |
| <b>LU</b>                                      | soft white          | +\$0 |
| <b>WL</b>                                      | sandstone           | +\$0 |
| <b>WN</b>                                      | warm grey neutral   | +\$0 |

| Step 8. Base Finish |  |        |
|---------------------|--|--------|
| <b>8Q</b>           | folkstone grey   | +\$0   |
| <b>91</b>           | white  | +\$0   |
| <b>98</b>           | studio white <span style="border: 1px solid black; padding: 0 2px;">A</span> | +\$0   |
| <b>BU</b>           | black umber  | +\$0   |
| <b>CL</b>           | cool grey neutral  | +\$0   |
| <b>G2</b>           | graphite satin   | +\$0   |
| <b>HF</b>           | inner tone light   | +\$0   |
| <b>LU</b>           | soft white   | +\$0   |
| <b>MT</b>           | medium tone  | +\$0   |
| <b>SG</b>           | slate grey   | +\$0   |
| <b>WL</b>           | sandstone  | +\$0   |
| <b>WN</b>           | warm grey neutral  | +\$0   |
| <b>CN</b>           | metallic champagne   | +\$20  |
| <b>EH</b>           | metallic bronze  | +\$20  |
| <b>MS</b>           | metallic silver  | +\$20  |
| <b>CD</b>           | polished aluminum  | +\$110 |

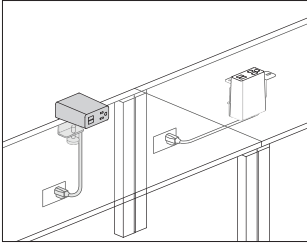

**Product Information**

**Description**

This electrical distributor plugs directly into floor, wall, or ceiling drop outlets. Each module configuration presents the same visual appearance. Cable clips and attachment hardware included. Product is UL listed.

**Notes**

- ..... Cable clips for cord management are intended for a 1-time installation.
- ..... Clamp versions can be reoriented in the field by a technician.
- ..... A small LED light illuminates through the USB ports when the USB version is plugged in and powered.
- ..... USB ports provide 10-watt power to charge most devices and tablets at full speed.
- ..... Cord color is predetermined. For white (G1) finish cords will be white. For graphite (G1) finish cords will be black.
- ..... Grommet mount attachment (Y1414.xxxG) does not come with the mini grommet. Order Logic mini grommet (Y1412.) separately, as needed.

**Dimensions**

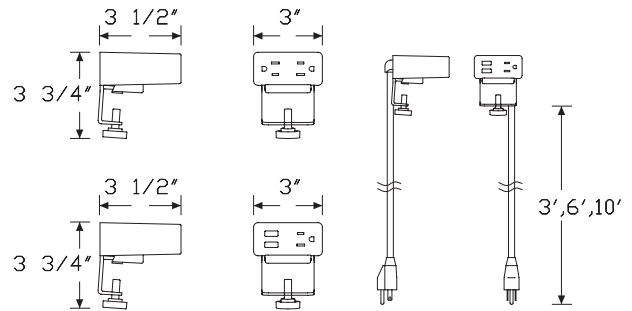

**Surface Clamp**

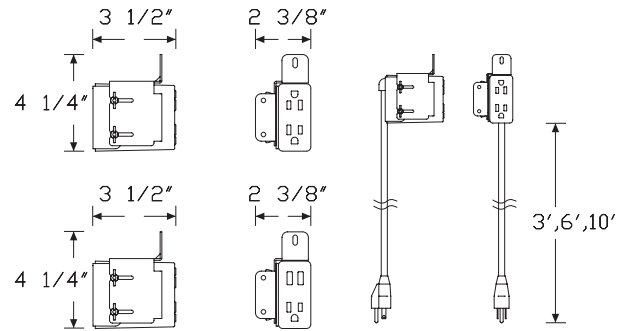

**Grommet Mount**

**Specification Information**

Step 1.

**Y1414.**  A

Step 2. Configuration

**J** 1 simplex receptacles, 2 powered USB  A

**K** 2 simplex receptacles  A

Step 3. Cord/Conduit Length

**03** 3' cord/conduit  A

**06** 6' cord/conduit  A

**10** 10' cord/conduit  A

Step 4. Attachment

**G** grommet mount  A

**S** surface clamp  A

Prices for Steps 1-4.

|                 |             | <b>G</b> | <b>S</b> |
|-----------------|-------------|----------|----------|
| <b>Y1414. J</b> | <b>03</b>   | \$332    | 332      |
|                 | <b>06</b>   | \$332    | 332      |
|                 | <b>10</b>   | \$342    | 342      |
|                 | <b>K 03</b> | \$185    | 185      |
|                 | <b>06</b>   | \$185    | 185      |
|                 | <b>10</b>   | \$195    | 195      |

Step 5. Finish

**91** white  A +\$0

**98** studio white  A +\$0

**G1** graphite  A +\$0

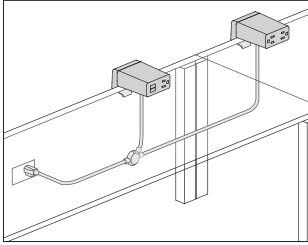

**Product Information**

**Description**

This electrical distributor plugs directly into floor, wall, or ceiling drop outlets. Each module configuration presents the same visual appearance. Cable clips and attachment hardware included. Product is ETL listed to UL962.

**Notes**

Cable clips for cord management are intended for a 1-time installation.

Clamp versions can be reoriented in the field by a technician.

Jumper length denotes distance between center points of each split point.

Cord length denotes distance from plug end to first split point.

All branch lengths from main power cord to module are 12".

A small LED light illuminates through the USB ports when the USB version is plugged in and powered.

USB ports provide 10-watt power to charge most devices and tablets at full speed.

The cord head contains a circuit breaker when there are more than 3 simplex receptacles.

Grommet mount attachment (Y1415.xxxxG) does not come with the mini grommet. Order Logic mini grommet (Y1412.) separately, as needed.

**Dimensions**

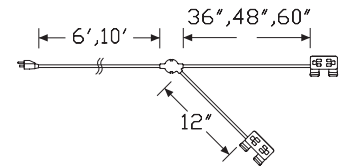
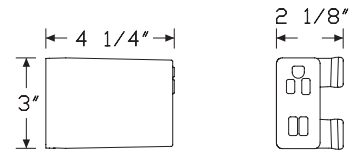

Two Power Modules

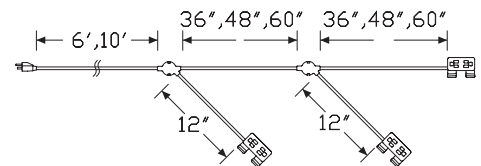

Three Power Modules

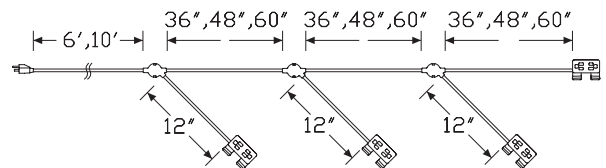

Four Power Modules

**Specification Information**

Step 1.

**Y1415.**  A

Step 2. Number of Modules

- 2** two power modules  A
- 3** three power modules  A
- 4** four power modules  A

Step 3. Power Type

- J** 1 simplex receptacles, 2 powered USB, all modules  A
- K** 2 simplex receptacles, all modules  A
- L** first module has 1 AC plus 2 powered USB all other modules have all AC simplex  A

Step 4. Jumper Length

- 36** 36" between split points  A
- 48** 48" between split points  A
- 60** 60" between split points  A

Step 5. Attachment

- G** grommet mount  A
- S** surface clamp  A

Step 6. Cord/Conduit Length

- 06** 6' cord/conduit  A
- 10** 10' cord/conduit  A

Prices for Steps 1-6.

|                 |          | <b>36G06</b> | <b>36G10</b> | <b>36S06</b> | <b>36S10</b> | <b>48G06</b> | <b>48G10</b> |
|-----------------|----------|--------------|--------------|--------------|--------------|--------------|--------------|
| <b>Y1415. 2</b> | <b>J</b> | \$736        | 746          | 736          | 746          | 744          | 754          |
|                 | <b>K</b> | \$441        | 451          | 441          | 451          | 449          | 459          |
|                 | <b>L</b> | \$588        | 599          | 588          | 599          | 597          | 607          |
| <b>3</b>        | <b>J</b> | \$1096       | 1106         | 1096         | 1106         | 1112         | 1122         |
|                 | <b>K</b> | \$669        | 680          | 669          | 680          | 686          | 696          |
|                 | <b>L</b> | \$817        | 827          | 817          | 827          | 833          | 844          |
| <b>4</b>        | <b>J</b> | \$1488       | 1499         | 1488         | 1499         | 1513         | 1523         |
|                 | <b>K</b> | \$898        | 908          | 898          | 908          | 923          | 933          |
|                 | <b>L</b> | \$1046       | 1056         | 1046         | 1056         | 1070         | 1080         |
|                 |          | <b>48S06</b> | <b>48S10</b> | <b>60G06</b> | <b>60G10</b> | <b>60S06</b> | <b>60S10</b> |
| <b>Y1415. 2</b> | <b>J</b> | \$744        | 754          | 752          | 763          | 752          | 763          |
|                 | <b>K</b> | \$449        | 459          | 457          | 467          | 457          | 467          |
|                 | <b>L</b> | \$597        | 607          | 605          | 615          | 605          | 615          |
| <b>3</b>        | <b>J</b> | \$1112       | 1122         | 1129         | 1139         | 1129         | 1139         |
|                 | <b>K</b> | \$686        | 696          | 702          | 712          | 702          | 712          |
|                 | <b>L</b> | \$833        | 844          | 850          | 860          | 850          | 860          |

|          |          |        |      |      |      |      |      |
|----------|----------|--------|------|------|------|------|------|
| <b>4</b> | <b>J</b> | \$1513 | 1523 | 1548 | 1558 | 1548 | 1558 |
|          | <b>K</b> | \$923  | 933  | 947  | 957  | 947  | 957  |
|          | <b>L</b> | \$1070 | 1080 | 1095 | 1105 | 1095 | 1105 |

Step 7. Finish

- 91** white  A +\$0
- 98** studio white  A +\$0
- G1** graphite  A +\$0

# Logic C1000 Universal Clamp Mount Distributor

Y1423.

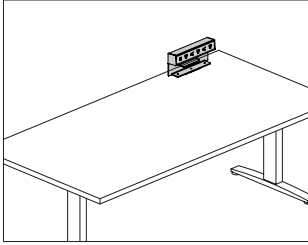

## Product Information

### Description

This Logic Power Access Solutions™ clamp mounted electrical distributor comes in several widths and configurations of simplex receptacles and USB charging ports. The unit is powered using a standard power cord with plug end or a hard-wired connection with electrical conduit. Data cords can be routed through the integrated opening at the rear of the unit. Product is UL listed.

### Notes

Clamp mounts on worksurfaces 1"-1 1/4" thick.

Faceplate color matches unit color.

Simplex receptacles have alternating orientation and greater than normal plug spacing to accommodate most plug types.

USB ports supply 10-watt power and will charge most small electronic devices. Software in each device controls that devices ability to accept a charge via USB.

## Dimensions

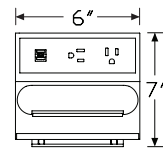
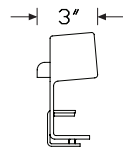

2 simplex receptacles, 2 powered USB

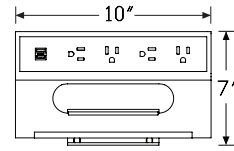
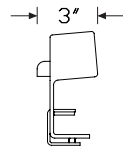

4 simplex receptacles, 2 powered USB

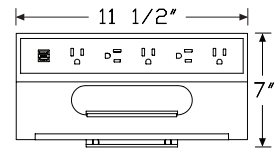
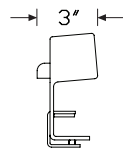

5 simplex receptacles, 2 powered USB

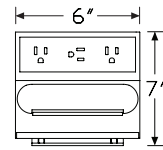
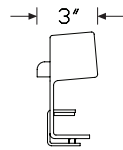

3 simplex receptacles

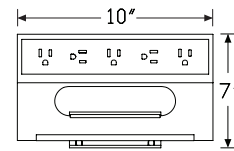
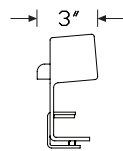

5 simplex receptacles

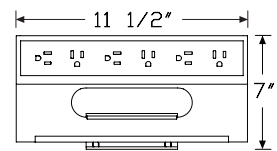
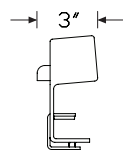

6 simplex receptacles

# Logic C1000 Universal Clamp Mount Distributor *continued*

Everywhere™ Power and Data Support

## Specification Information

### Step 1.

**Y1423.**  A

### Step 2. Configuration

- A** 2 simplex receptacles, 2 powered USB  A
- C** 4 simplex receptacles, 2 powered USB  A
- D** 5 simplex receptacles, 2 powered USB  A
- E** 3 simplex receptacles  A
- F** 5 simplex receptacles  A
- G** 6 simplex receptacles  A

### Step 3. Power Type

- A** power cord with plug end  A
- B** conduit with open end, for hard-wiring  A

### Step 4. Cord/Conduit Length

- 03** 3' cord/conduit  A
- 06** 6' cord/conduit  A
- 10** 10' cord/conduit  A

### Prices for Steps 1-4.

|                 |          | <b>03</b> | <b>06</b> | <b>10</b> |
|-----------------|----------|-----------|-----------|-----------|
| <b>Y1423. A</b> | <b>A</b> | \$449     | 449       | 459       |
|                 | <b>B</b> | \$498     | 498       | 508       |
| <b>C</b>        | <b>A</b> | \$539     | 539       | 549       |
|                 | <b>B</b> | \$588     | 588       | 599       |
| <b>D</b>        | <b>A</b> | \$577     | 577       | 587       |
|                 | <b>B</b> | \$626     | 626       | 637       |
| <b>E</b>        | <b>A</b> | \$301     | 301       | 312       |
|                 | <b>B</b> | \$351     | 351       | 361       |
| <b>F</b>        | <b>A</b> | \$392     | 392       | 402       |
|                 | <b>B</b> | \$441     | 441       | 451       |
| <b>G</b>        | <b>A</b> | \$429     | 429       | 440       |
|                 | <b>B</b> | \$479     | 479       | 489       |

### Step 5. Finish

- 91** white  A +\$0
- 98** studio white  A +\$0
- G1** graphite  A +\$0
- MS** metallic silver  A +\$0



# Logic G1000 Grommet Mounted Electrical Distributor

Y1425.

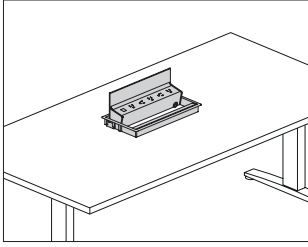

## Product Information

### Description

This Logic Power Access Solutions™ grommet mounted electrical distributor comes in several widths and configurations of simplex receptacles and USB charging ports. The unit is powered using a standard power cord with plug end, a hard-wired connection with electrical conduit, or an IEC connector when used with Renew™ Sit-to-Stand tables. An integrated cord keeper at the face of the unit captures data cords. The unit pivots from a closed position to 135° allowing easy access to power and data cords stored beneath the unit. Product is UL listed.

### Notes

Field cutting of grommet cutout is possible.

IEC connector for Renew power type (C) includes short cord designed to connect to the Renew table power cord through-leg option. Actual cord length may vary.

Simplex receptacles have alternating orientation and greater than normal plug spacing to accommodate most plug types.

USB ports supply 10-watt power and will charge most small electronic devices. Software in each device controls that devices ability to accept a charge via USB.

Refer to Renew™ Sit-to-Stand Tables and Locale® planning guides for specific application information.

20' cord/conduit length (20) is recommended for Exclave® applications.

## Dimensions

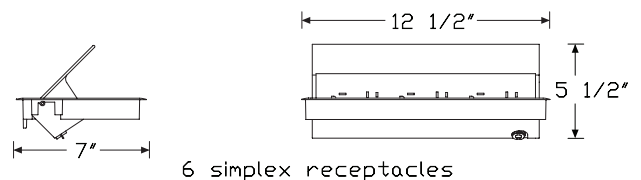
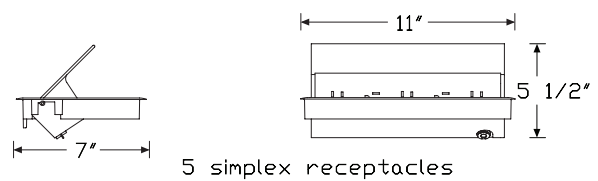
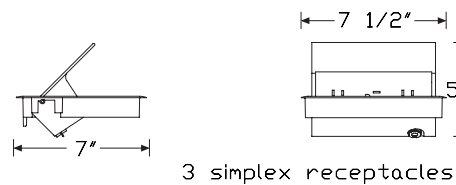
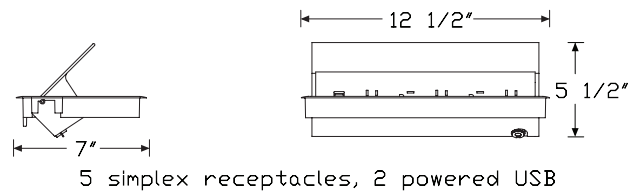
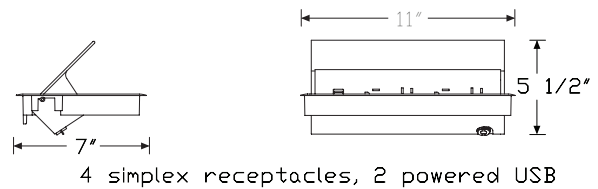
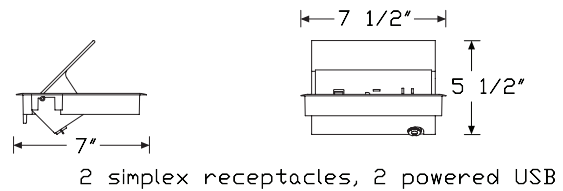

Everywhere™ Power and Data Support

# Logic G1000 Grommet Mounted Electrical Distributor *continued*

Everywhere™ Power and Data Support

## Specification Information

### Step 1.

**Y1425.**  A

### Step 2. Configuration

- A** 2 simplex receptacles, 2 powered USB  A
- C** 4 simplex receptacles, 2 powered USB  A
- D** 5 simplex receptacles, 2 powered USB  A
- E** 3 simplex receptacles  A
- F** 5 simplex receptacles  A
- G** 6 simplex receptacles  A

### Step 3. Power Type

- A** power cord with plug end  A
- B** conduit with open end, for hard-wiring  A
- C** IEC connector for Renew Tables  A

### Step 4. Cord/Conduit Length

#### *For power cord with plug end (A)*

- 03** 3' cord/conduit  A
- 06** 6' cord/conduit  A
- 10** 10' cord/conduit  A

#### *For conduit with open end, for hard-wiring (B)*

- 03** 3' cord/conduit  A
- 06** 6' cord/conduit  A
- 10** 10' cord/conduit  A

#### *For IEC connector for Renew Tables (C)*

- 03** 3' cord/conduit  A

### Prices for Steps 1-4.

|                 |          | <b>03</b> | <b>06</b> | <b>10</b> |
|-----------------|----------|-----------|-----------|-----------|
| <b>Y1425. A</b> | <b>A</b> | \$639     | 639       | 649       |
|                 | <b>B</b> | \$688     | 688       | 698       |
|                 | <b>C</b> | \$649     | —         | —         |
| <b>C</b>        | <b>A</b> | \$741     | 741       | 751       |
|                 | <b>B</b> | \$790     | 790       | 801       |
|                 | <b>C</b> | \$751     | —         | —         |
| <b>D</b>        | <b>A</b> | \$807     | 807       | 817       |
|                 | <b>B</b> | \$856     | 856       | 866       |
|                 | <b>C</b> | \$817     | —         | —         |
| <b>E</b>        | <b>A</b> | \$491     | 491       | 501       |
|                 | <b>B</b> | \$540     | 540       | 550       |
|                 | <b>C</b> | \$501     | —         | —         |

|          |          |       |     |     |
|----------|----------|-------|-----|-----|
| <b>F</b> | <b>A</b> | \$593 | 593 | 604 |
|          | <b>B</b> | \$643 | 643 | 653 |
|          | <b>C</b> | \$604 | —   | —   |
| <b>G</b> | <b>A</b> | \$659 | 659 | 669 |
|          | <b>B</b> | \$708 | 708 | 719 |
|          | <b>C</b> | \$669 | —   | —   |

### Step 5. Finish

|           |  |  |  |      |
|-----------|--|--|--|------|
| <b>91</b> | white <input type="checkbox"/> A           |  |  | +\$0 |
| <b>98</b> | studio white <input type="checkbox"/> A    |  |  | +\$0 |
| <b>G1</b> | graphite <input type="checkbox"/> A        |  |  | +\$0 |
| <b>MS</b> | metallic silver <input type="checkbox"/> A |  |  | +\$0 |

# Logic Mini Grommet

Y1412.

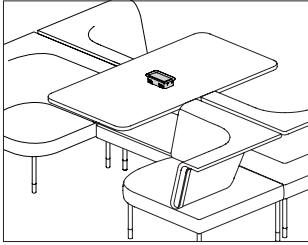

### Product Information

#### Description

This Logic Power Access Solutions™ plastic grommet is available in mini rectangle or mini square configuration. The integrated flaps can hide the things below the surface while also retaining power and data cords.

#### Notes

This grommet is installed in some HermanMiller applications. Verify your application before ordering grommet separately.

#### Dimensions

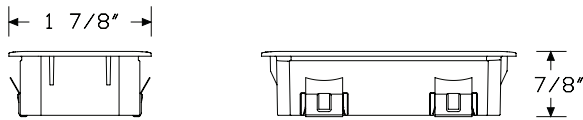
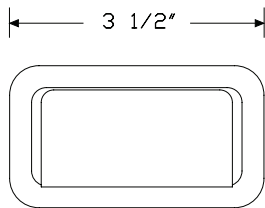

Grommet - Rectangle

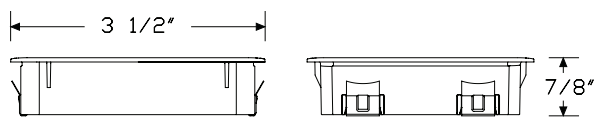
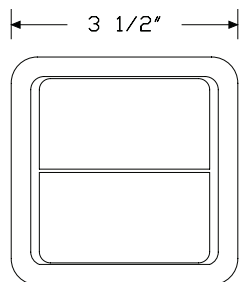

Grommet - Square

### Specification Information

#### Step 1.

**Y1412.**

#### Step 2. Configuration

- 1 mini rectangle grommet
- 2 mini square grommet

#### Prices for Steps 1-2.

|                 |      |
|-----------------|------|
| <b>Y1412. 1</b> | \$26 |
| <b>2</b>        | \$30 |

#### Step 3. Finish

|           |              |      |
|-----------|--------------|------|
| <b>91</b> | white        | +\$0 |
| <b>98</b> | studio white | +\$0 |
| <b>G1</b> | graphite     | +\$0 |

Everywhere™ Power and Data Support

Logic G1200 Grommet Pass Thru Y1420.

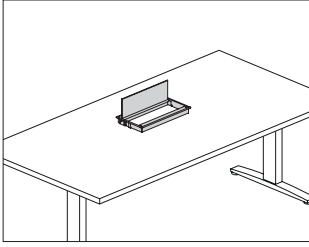

**Product Information**

**Description**  
 This Logic Power Access Solutions™ grommet mounted metal enclosure provides access to cords kept beneath the surface. The unit has an integrated cord keeper.

**Notes**

Unit size is based on the grommet mounted electrical distributor (Y1425.) with simplex receptacles.

**Dimensions**

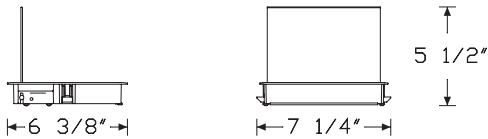

3 outlet opening (T)

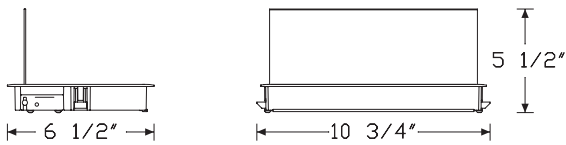

5 outlet opening (V)

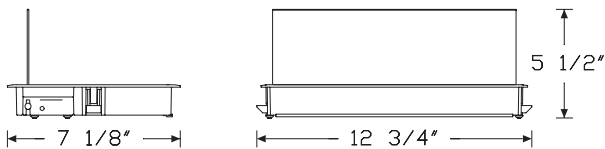

6 outlet opening (X)

**Specification Information**

Step 1.

**Y1420.**  A

Step 2. Configuration

**T** three outlet opening  A

**V** five outlet opening  A

**X** six outlet opening  A

Prices for Steps 1-2.

|                 |       |
|-----------------|-------|
| <b>Y1420. T</b> | \$214 |
| <b>V</b>        | \$235 |
| <b>X</b>        | \$255 |

Step 3. Finish

|  |      |
|--|------|
| <b>91</b> white <input type="checkbox"/> A           | +\$0 |
| <b>98</b> studio white <input type="checkbox"/> A    | +\$0 |
| <b>G1</b> graphite <input type="checkbox"/> A        | +\$0 |
| <b>MS</b> metallic silver <input type="checkbox"/> A | +\$0 |

Everywhere™ Power and Data Support

Logic HD Cable Manager

Y1424.

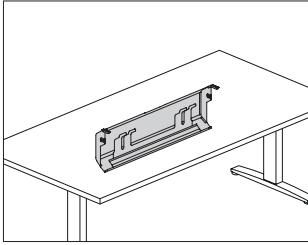

**Product Information**

Description

This Logic Power Access Solutions™ stand-alone cable management tray mounts to the underside of most surfaces. It can be used with a Logic unit for cord storage, or used alone with cords routed through the back side of the unit. Tray drops down and holds cords in place while working and can be easily stowed back in place.

Dimensions

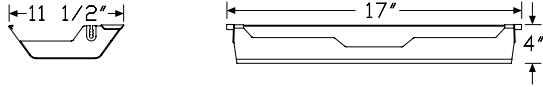

**Specification Information**

Step 1.

**Y1424.**  A

Step 2. Size

**17** 17" wide tray  A

Prices for Steps 1-2.

**Y1424. 17** \$235

Step 3. Finish

- 91** white  A +\$0
- 98** studio white  A +\$0
- G1** graphite  A +\$0
- MS** metallic silver  A +\$0

Everywhere™ Power and Data Support

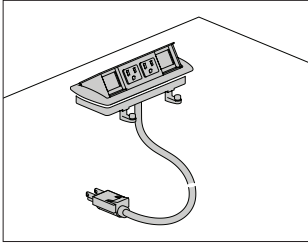

**Product Information**

**Description**

This electrical distributor mounts flush in a surface and has a one-touch pop-up mechanism for accessing power and data. It has 2 simplex receptacles and 2 data openings, and is available with a power cord with plug end, or electrical conduit for hardwire connection. A voice/data adapter kit is included, allowing the data openings to accept various manufacturers' couplers and jacks. Attachment hardware and cord/cable clips are also included. Product is UL listed.

**Notes**

Field cutting of surface may be required. Information on surface cutout size is included on instruction sheet.

Distributor with PVC-free wiring option (LZ) is Cradle to Cradle Silver Certified.

**Dimensions**

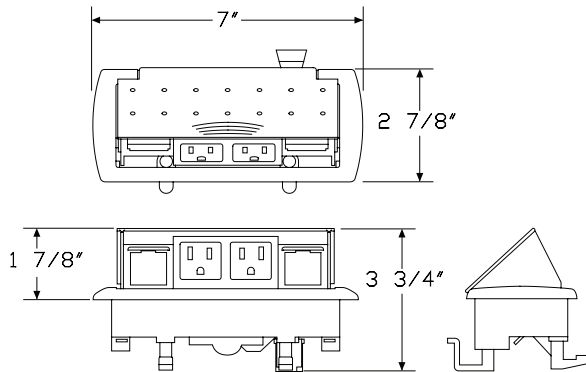

**Specification Information**

**Step 1.**

**Y1321.**

**Step 2. Power Type**

- A** power cord with plug end
- B** conduit with open end, for hard-wiring

**Step 3. Cord/Conduit Length**

- 03** 3' cord/conduit
- 06** 6' cord/conduit
- 10** 10' cord/conduit
- 20** 20' cord/conduit

**Prices for Steps 1-3.**

|                 | <b>03</b> | <b>06</b> | <b>10</b> | <b>20</b> |
|-----------------|-----------|-----------|-----------|-----------|
| <b>Y1321. A</b> | \$199     | 199       | 208       | 255       |
| <b>B</b>        | \$251     | 251       | 260       | 308       |

**Step 4. Wiring Type**

- 4Z** standard +\$0
- LZ** PVC-free +\$39

**Step 5. Finish**

- 0H** black +\$0

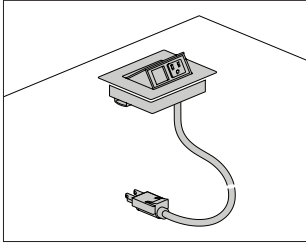

**Product Information**

**Description**

This electrical distributor mounts flush in a surface and has a one-touch pop-up mechanism for accessing power and data. It can be configured with 2 simplex receptacles, or 1 simplex receptacle and 1 data opening. The distributor is available with a power cord with plug end, or electrical conduit for hardwire connection. A voice/data adapter kit is included, allowing the data openings to accept various manufacturers' couplers and jacks. Attachment hardware and cord/cable clips are also included. Product is UL listed.

**Notes**

Field cutting of surface may be required. Information on surface cutout size is included on instruction sheet.

Distributor with PVC-free wiring option (LZ) is Cradle to Cradle Silver Certified.

Distributor with silver finish option (OI) or white finish option (OJ) and standard wiring (4Z) has painted metal trim with white plastic simplex/data interior. Distributor with black finish option (OH) and standard wiring (4Z) has black painted trim with black plastic simplex/data interior. Distributor with PVC-free wiring option (LZ) has black plastic simplex/data interior, regardless of the finish color.

**Dimensions**

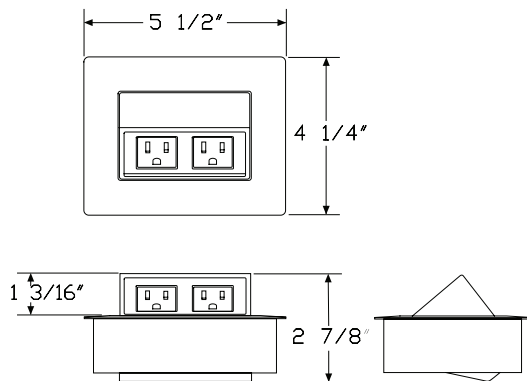

**Specification Information**

**Step 1.**

**Y1322.**

**Step 2. Configuration**

- 1 1 simplex receptacle, 1 data opening
- 2 2 simplex receptacles

**Step 3. Power Type**

- A power cord with plug end
- B conduit with open end, for hard-wiring

**Step 4. Cord/Conduit Length**

- 03 3' cord/conduit
- 06 6' cord/conduit
- 10 10' cord/conduit
- 20 20' cord/conduit

**Prices for Steps 1-4.**

|                 |            | 03    | 06  | 10  | 20  |
|-----------------|------------|-------|-----|-----|-----|
| <b>Y1322. 1</b> | <b>A</b>   | \$237 | 237 | 246 | 293 |
|                 | <b>B</b>   | \$288 | 288 | 297 | 343 |
|                 | <b>2 A</b> | \$251 | 251 | 260 | 308 |
|                 | <b>B</b>   | \$302 | 302 | 313 | 360 |

**Step 5. Wiring Type**

- 4Z standard +\$0
- LZ PVC-free +\$39

**Step 6. Finish**

- OH black +\$0
- OI silver +\$0
- OJ white +\$0

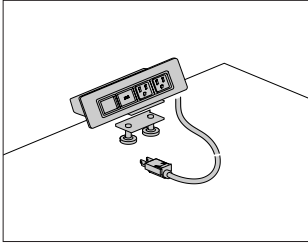

**Product Information**

**Description**

This electrical distributor can grommet-mount flush in a surface, or clamp-mount to the edge. It can be configured with 2 simplex receptacles and 2 data openings, or 3 simplex receptacles and 3 data openings. The distributor is available with a power cord with plug end, or electrical conduit for hardwire connection. A voice/data adapter kit is included, allowing the data openings to accept various manufacturers' couplers and jacks. Attachment hardware and cord/cable clips are also included. Product is UL listed.

**Notes**

Field cutting of surface may be required. Information on surface cutout size is included on instruction sheet.  
 Silver option (ol) and white option (oj) have painted metal trim with white plastic simplex/data interiors. Black option (oh) has black painted trim with black plastic simplex/data interior.  
 Overall width for distributor with 2 simplex receptacles, 2 data openings option (3) is 8" wide. Overall width for distributor with 3 simplex receptacles, 3 data openings option (4) is 11" wide.

**Dimensions**

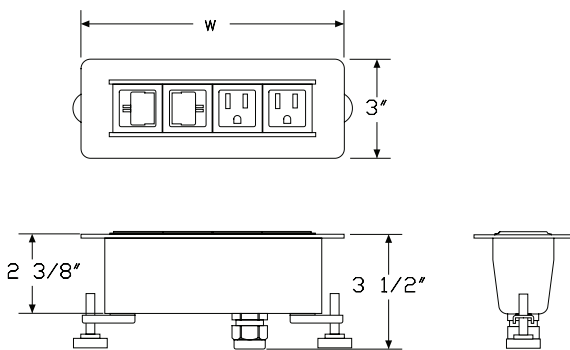

**Specification Information**

**Step 1.**

**Y1323.**

**Step 2. Configuration**

- 3** 2 simplex receptacles, 2 data openings
- 4** 3 simplex receptacles, 3 data openings

**Step 3. Power Type**

- A** power cord with plug end
- B** conduit with open end, for hard-wiring

**Step 4. Cord/Conduit Length**

- 03** 3' cord/conduit
- 06** 6' cord/conduit
- 10** 10' cord/conduit
- 20** 20' cord/conduit

**Step 5. Attachment**

- G** grommet mount
- S** surface clamp

**Prices for Steps 1-5.**

|                 |          | <b>03G</b> | <b>03S</b> | <b>06G</b> | <b>06S</b> | <b>10G</b> | <b>10S</b> |
|-----------------|----------|------------|------------|------------|------------|------------|------------|
| <b>Y1323. 3</b> | <b>A</b> | \$271      | 271        | 271        | 271        | 280        | 280        |
|                 | <b>B</b> | \$322      | 322        | 322        | 322        | 331        | 331        |
| <b>4</b>        | <b>A</b> | \$337      | 337        | 337        | 337        | 346        | 346        |
|                 | <b>B</b> | \$390      | 390        | 390        | 390        | 400        | 400        |
|                 |          |            |            | <b>20G</b> | <b>20S</b> |            |            |
| <b>Y1323. 3</b> | <b>A</b> |            |            |            |            | \$327      | 327        |
|                 | <b>B</b> |            |            |            |            | \$377      | 377        |
| <b>4</b>        | <b>A</b> |            |            |            |            | \$395      | 395        |
|                 | <b>B</b> |            |            |            |            | \$446      | 446        |

**Step 6. Finish**

- OH** black +\$0
- OI** silver +\$0
- OJ** white +\$0



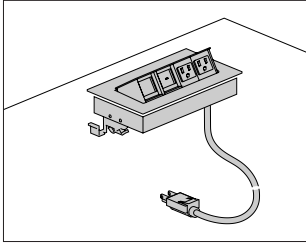

**Product Information**

**Description**

This electrical distributor mounts flush in a surface and has a one-touch pop-up mechanism for accessing power and data. It can be configured with 2 simplex receptacles and 2 data openings, or 3 simplex receptacles and 4 data openings. The distributor is available with a power cord with plug end, or electrical conduit for hardwire connection. A voice/data adapter kit is included, allowing the data openings to accept various manufacturers' couplers and jacks. Attachment hardware and cord/cable clips are also included. Product is UL listed.

**Notes**

Field cutting of surface may be required. Information on surface cutout size is included on instruction sheet.

Distributor with PVC-free wiring option (LZ) is Cradle to Cradle Silver Certified.

Distributor with silver anodized finish option (oK) and standard wiring (4Z) has anodized trim with white plastic simplex/data interior. Distributor with silver anodized finish option (oK) and PVC-free wiring (LZ) has anodized trim with black plastic simplex/data interior.

Overall width for distributor with 2 simplex receptacles, 2 data openings option (3) is 8 1/4" wide. Overall width for distributor with 3 simplex receptacles, 4 data openings option (5) is 12 3/4" wide.

**Dimensions**

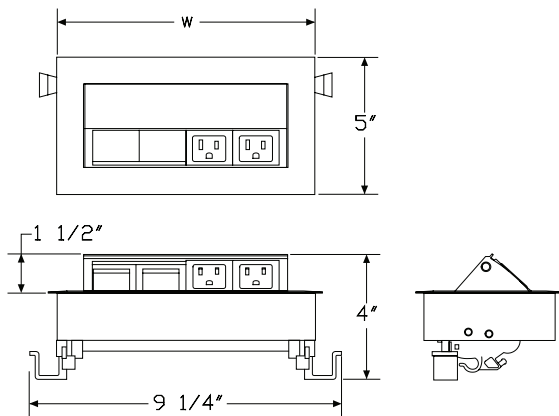

**Specification Information**

**Step 1.**

**Y1324.**

**Step 2. Configuration**

- 3** 2 simplex receptacles, 2 data openings
- 5** 3 simplex receptacles, 4 data openings

**Step 3. Power Type**

- A** power cord with plug end
- B** conduit with open end, for hard-wiring

**Step 4. Cord/Conduit Length**

- 03** 3' cord/conduit
- 06** 6' cord/conduit
- 10** 10' cord/conduit
- 20** 20' cord/conduit

**Prices for Steps 1-4.**

|                 |            | <b>03</b> | <b>06</b> | <b>10</b> | <b>20</b> |
|-----------------|------------|-----------|-----------|-----------|-----------|
| <b>Y1324. 3</b> | <b>A</b>   | \$377     | 377       | 386       | 434       |
|                 | <b>B</b>   | \$429     | 429       | 440       | 486       |
|                 | <b>5 A</b> | \$485     | 485       | 495       | 541       |
|                 | <b>B</b>   | \$537     | 537       | 543       | 589       |

**Step 5. Wiring Type**

- 4Z** standard +\$0
- LZ** PVC-free +\$39

**Step 6. Finish**

- OK** silver anodized +\$0

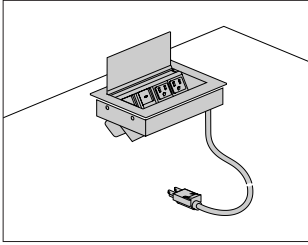

**Product Information**

**Description**  
 This electrical distributor mounts flush in a surface and has a flip-up lid for accessing power and data from above or below the surface. The flip lid can be closed once devices are connected for a clean visual appearance. It can be configured with 2 simplex receptacles and 2 data openings, or 3 simplex receptacles and 3 data openings. The distributor is available with a power cord with plug end, or electrical conduit for hardwire connection. A voice/data adapter kit is included, allowing the data openings to accept various manufacturers' couplers and jacks. Attachment hardware and cord/cable clips are also included. Product is UL listed.

**Notes**

Field cutting of surface may be required. Information on surface cutout size is included on instruction sheet.  
 Silver anodized option (OK) has anodized trim with white plastic simplex/data interior.  
 Overall width for distributor with 2 simplex receptacles, 2 data openings option (3) is 8<sup>3</sup>/<sub>8</sub>" wide. Overall width for distributor with 3 simplex receptacles, 3 data openings option (4) is 11<sup>3</sup>/<sub>8</sub>" wide.

**Dimensions**

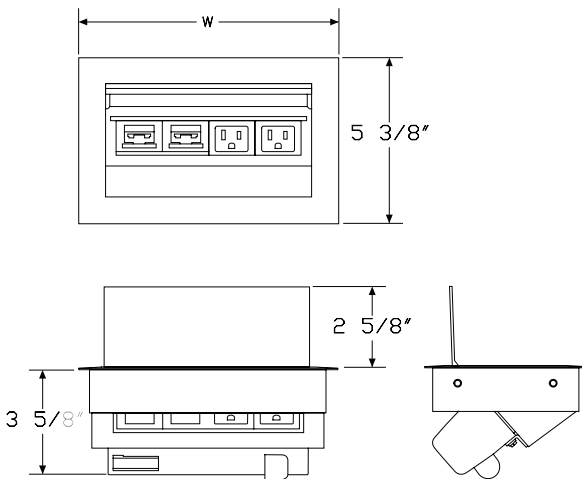

**Specification Information**

**Step 1.**

**Y1325.**

**Step 2. Configuration**

|          |  |
|----------|--|
| <b>3</b> | 2 simplex receptacles, 2 data openings |
| <b>7</b> | 3 simplex receptacles, 3 data openings |

**Step 3. Power Type**

|          |  |
|----------|--|
| <b>A</b> | power cord with plug end               |
| <b>B</b> | conduit with open end, for hard-wiring |

**Step 4. Cord/Conduit Length**

|           |                  |
|-----------|------------------|
| <b>03</b> | 3' cord/conduit  |
| <b>06</b> | 6' cord/conduit  |
| <b>10</b> | 10' cord/conduit |
| <b>20</b> | 20' cord/conduit |

**Prices for Steps 1-4.**

|                 |            | <b>03</b> | <b>06</b> | <b>10</b> | <b>20</b> |
|-----------------|------------|-----------|-----------|-----------|-----------|
| <b>Y1325. 3</b> | <b>A</b>   | \$445     | 445       | 454       | 501       |
|                 | <b>B</b>   | \$497     | 497       | 506       | 552       |
|                 | <b>7 A</b> | \$511     | 511       | 522       | 569       |
|                 | <b>B</b>   | \$563     | 563       | 574       | 620       |

**Step 5. Finish**

|           |                 |  |  |  |      |
|-----------|-----------------|--|--|--|------|
| <b>OK</b> | silver anodized |  |  |  | +\$0 |
|-----------|-----------------|--|--|--|------|

# Cable Management Clip

DT9A.

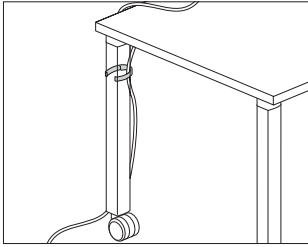

### Product Information

#### Description

This plastic clip snaps onto an Everywhere™ table leg to route cables or cords. Finish is clear. Package of 10.

#### Dimensions

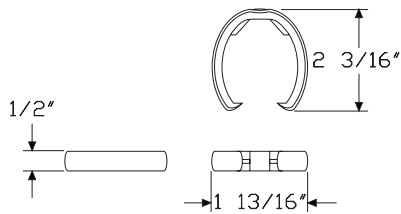

### Specification Information

#### Step 1.

DT9A.

\$36

# Vertical Cord Covers

DT9B.

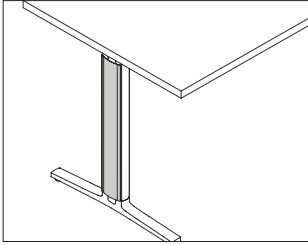

### Product Information

**Description**  
 These cord covers attach to Everywhere table T-leg and Y-leg sections that have either casters or glides. The covers are field installed, and are easily removed and reinstalled for ease of cable management.

### Notes

The T cover works with both the (T) and (C) base options.  
 The Y cover works with both the (E) and (G) base options.  
 To ensure proper height of the covers, select (C) if your table has casters or select (G) if your table has glides.

### Dimensions

Everywhere™ Accessories

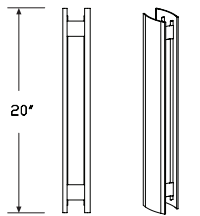

T-leg with casters

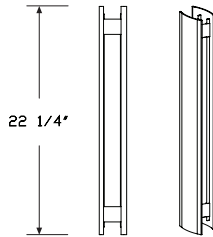

T-leg with glides

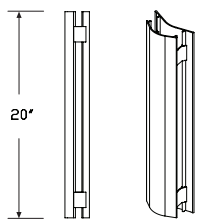

Y-leg with casters

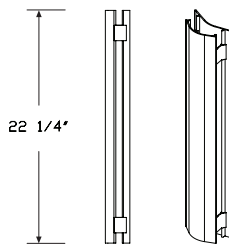

Y-leg with glides

### Specification Information

#### Step 1.

**DT9B.**

#### Step 2. Leg Type

- T** T-leg
- E** Y-leg

#### Prices for Steps 1-2.

|                |       |
|----------------|-------|
| <b>DT9B. T</b> | \$258 |
| <b>E</b>       | \$258 |

#### Step 3. Caster or Glide Table

|          |                            |      |
|----------|----------------------------|------|
| <b>C</b> | for table with caster base | +\$0 |
| <b>G</b> | for table with glide base  | +\$0 |

#### Step 4. Leg/Base Finish

|           |                    |       |
|-----------|--------------------|-------|
| <b>8Q</b> | folkstone grey     | +\$0  |
| <b>91</b> | white              | +\$0  |
| <b>98</b> | studio white       | +\$0  |
| <b>BU</b> | black umber        | +\$0  |
| <b>CL</b> | cool grey neutral  | +\$0  |
| <b>G2</b> | graphite satin     | +\$0  |
| <b>HF</b> | inner tone light   | +\$0  |
| <b>LU</b> | soft white         | +\$0  |
| <b>MT</b> | medium tone        | +\$0  |
| <b>SG</b> | slate grey         | +\$0  |
| <b>WL</b> | sandstone          | +\$0  |
| <b>WN</b> | warm grey neutral  | +\$0  |
| <b>CN</b> | metallic champagne | +\$20 |
| <b>EH</b> | metallic bronze    | +\$20 |
| <b>MS</b> | metallic silver    | +\$20 |

# Modesty Panel

Y1113.

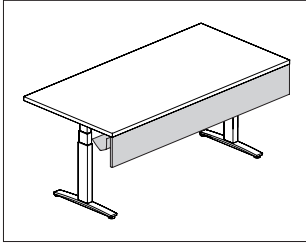

### Product Information

#### Description

This modesty panel attaches to a table, desk, peninsula, or work surface. It has a solid MDF core with a laminate or veneer surface, aluminum top rail and attachment brackets. Cable trough is optional. Attachment hardware included.

#### Notes

Specify modesty panel to be equal to surface width, or 6" less than surface width of a height adjustable table.  
 Modesty panel dimension is approximately 10" high with width specified in step 1. Actual width 1/4" less than specified value.  
 Modesty panel is field installed.  
 Brackets are located to work with Connect™ 2-circuit power system.  
 Modesty panel (Y1113.) may impede ideal folding functionality of flip top table (DT5Ax.). For use with flip top table, modesty panel (Y1114.) is recommended. It comes only with a fabric surface.

#### Dimensions

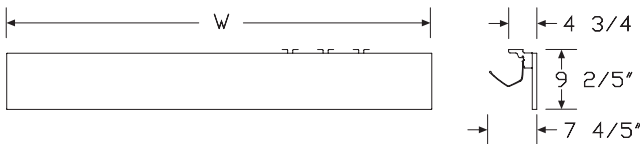

### Specification Information

#### Step 1.

**Y1113.**

#### Step 2. Width

|           |          |
|-----------|----------|
| <b>24</b> | 24" wide |
| <b>30</b> | 30" wide |
| <b>36</b> | 36" wide |
| <b>42</b> | 42" wide |
| <b>48</b> | 48" wide |
| <b>54</b> | 54" wide |
| <b>60</b> | 60" wide |
| <b>66</b> | 66" wide |
| <b>72</b> | 72" wide |

#### Step 3. Cable Trough

|          |                            |
|----------|----------------------------|
| <b>N</b> | without added cable trough |
| <b>Y</b> | with added cable trough    |

#### Step 4. Surface Material

|          |                                 |
|----------|---------------------------------|
| <b>L</b> | laminate top/thermoplastic edge |
| <b>W</b> | veneer top/veneer edge          |

#### Prices for Steps 1-4.

|                    | <b>L</b> | <b>W</b> |
|--------------------|----------|----------|
| <b>Y1113. 24 N</b> | \$188    | 334      |
| <b>Y</b>           | \$335    | 498      |
| <b>30 N</b>        | \$205    | 375      |
| <b>Y</b>           | \$380    | 568      |
| <b>36 N</b>        | \$224    | 417      |
| <b>Y</b>           | \$414    | 626      |
| <b>42 N</b>        | \$242    | 459      |
| <b>Y</b>           | \$456    | 692      |
| <b>48 N</b>        | \$260    | 500      |
| <b>Y</b>           | \$499    | 759      |
| <b>54 N</b>        | \$280    | 542      |
| <b>Y</b>           | \$541    | 826      |
| <b>60 N</b>        | \$298    | 583      |
| <b>Y</b>           | \$583    | 892      |
| <b>66 N</b>        | \$298    | 624      |
| <b>Y</b>           | \$625    | 958      |
| <b>72 N</b>        | \$322    | 665      |
| <b>Y</b>           | \$666    | 1024     |

## Modesty Panel *continued*

---

### Step 5. Finish

---

#### *For laminate top/thermoplastic edge (L)*

---

|           |                   |      |
|-----------|-------------------|------|
| <b>8Q</b> | folkstone grey    | +\$0 |
| <b>91</b> | white             | +\$0 |
| <b>LU</b> | soft white        | +\$0 |
| <b>WL</b> | sandstone         | +\$0 |
| <b>WN</b> | warm grey neutral | +\$0 |

---

#### *For veneer top/veneer edge (W)*

---

|           |                    |      |
|-----------|--------------------|------|
| <b>2U</b> | light brown walnut | +\$0 |
| <b>40</b> | dark brown walnut  | +\$0 |
| <b>UL</b> | natural maple      | +\$0 |

---

# Fabric Modesty Panel

Y1114.

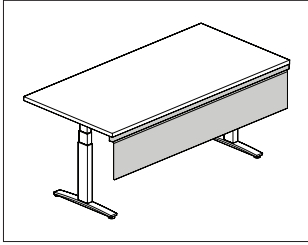

### Product Information

#### Description

This modesty panel attaches to a table, desk, peninsula, or work surface. It has a fabric surface with aluminum top rail and attachment brackets. Attachment hardware included.

#### Notes

Specify modesty panel to be equal to surface width, or 6" less than surface width of a height adjustable table.

For use with flip top table (DT5Ax.), modesty panel (Y1114.) is recommended to enable optimal folding functionality of the table.

#### Dimensions

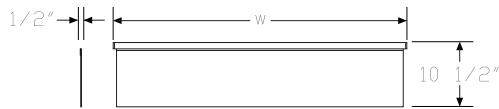

### Specification Information

#### Step 1.

Y1114.  A

#### Step 2. Width

- 24 24" wide  A
- 30 30" wide  A
- 36 36" wide  A
- 42 42" wide  A
- 48 48" wide  A
- 54 54" wide  A
- 60 60" wide  A
- 66 66" wide  A
- 72 72" wide  A

#### Prices for Steps 1-2.

|           |       |
|-----------|-------|
| Y1114. 24 | \$172 |
| 30        | \$187 |
| 36        | \$203 |
| 42        | \$215 |
| 48        | \$230 |
| 54        | \$258 |
| 60        | \$271 |
| 66        | \$286 |
| 72        | \$297 |

#### Step 3. Fabric

Price Category 1 + \$0

Everywhere™ Accessories

# Cable Trough

Y1200.

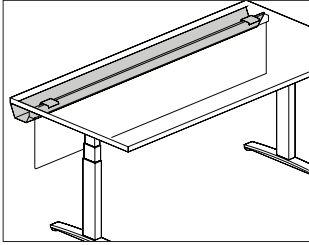

## Product Information

### Description

This trough attaches to a table, desk, peninsula, or work surface to hold and conceal cords and cables. It pivots down to allow easy access when laying cords inside, and can be specified with an optional modesty panel. The modesty panel has a fabric surface with aluminum top rail. Attachment hardware is included.

### Notes

Specify trough to be equal to or less than the surface width.

## Dimensions

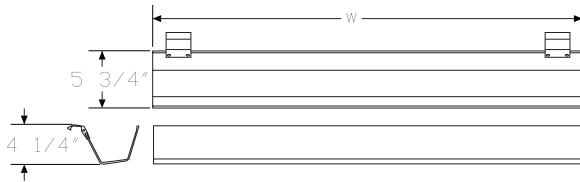

Everywhere™ Accessories

## Specification Information

### Step 1.

**Y1200.**

### Step 2. Width

- 24** 24" wide
- 30** 30" wide
- 36** 36" wide
- 42** 42" wide
- 48** 48" wide

### Step 3. Modesty Panel Option

- N** no modesty panel
- M** modesty panel

### Prices for Steps 1-3.

|                  |  | N     | M   |
|------------------|--|-------|-----|
| <b>Y1200. 24</b> |  | \$269 | 344 |
| <b>30</b>        |  | \$293 | 386 |
| <b>36</b>        |  | \$323 | 421 |
| <b>42</b>        |  | \$353 | 461 |
| <b>48</b>        |  | \$381 | 501 |

### Step 4. Cable Trough Finish

- AN** clear anodized aluminum + \$0

### Step 5. Modesty Panel Fabric

*For modesty panel (M)*

- Price Category 1 + \$0



Cable Management Trough, Work Surface Suspended AO382.

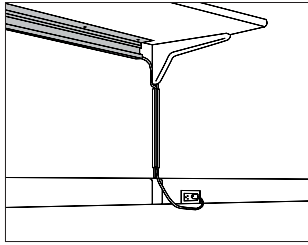

**Product Information**

**Description**

This trough attaches under an Action Office® suspended work surface to manage cables. Attachment hardware is included.

**Dimensions**

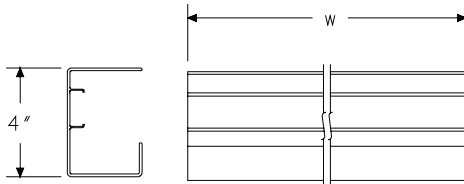

**Specification Information**

**Step 1.**

**AO382.**

**Step 2. Width**

**30** 30" wide

**40** 40" wide

**Prices for Steps 1-2.**

|                  |      |
|------------------|------|
| <b>AO382. 30</b> | \$74 |
| <b>40</b>        | \$90 |

**Step 3. Surface Finish**

|                       |      |
|-----------------------|------|
| <b>BU</b> black umber | +\$0 |
| <b>MT</b> medium tone | +\$0 |

# Cord Manager

FV984.

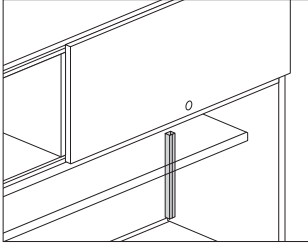

## Product Information

### Description

This cord manager routes a cord from the underside of a hutch to the surface when a task light is attached. Color is black. Package of 6.

### Dimensions

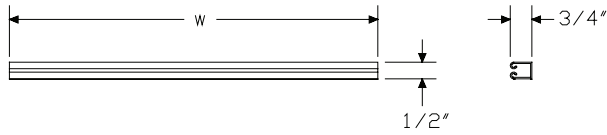

## Specification Information

### Step 1.

**FV984.**

### Step 2. Height

- 12** 12" high
- 24** 24" high
- 30** 29 1/2" high

### Prices for Steps 1-2.

|                  |       |
|------------------|-------|
| <b>FV984. 12</b> | \$77  |
| <b>24</b>        | \$117 |
| <b>30</b>        | \$142 |

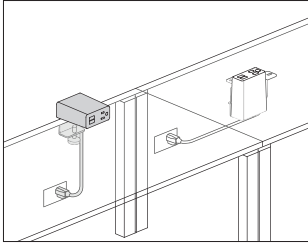

**Product Information**

**Description**

This electrical distributor plugs directly into floor, wall, or ceiling drop outlets. Each module configuration presents the same visual appearance. Cable clips and attachment hardware included. Product is UL listed.

**Notes**

- ..... Cable clips for cord management are intended for a 1-time installation.
- ..... Clamp versions can be reoriented in the field by a technician.
- ..... A small LED light illuminates through the USB ports when the USB version is plugged in and powered.
- ..... USB ports provide 10-watt power to charge most devices and tablets at full speed.
- ..... Cord color is predetermined. For white (G1) finish cords will be white. For graphite (G1) finish cords will be black.
- ..... Grommet mount attachment (Y1414.xxxG) does not come with the mini grommet. Order Logic mini grommet (Y1412.) separately, as needed.

**Dimensions**

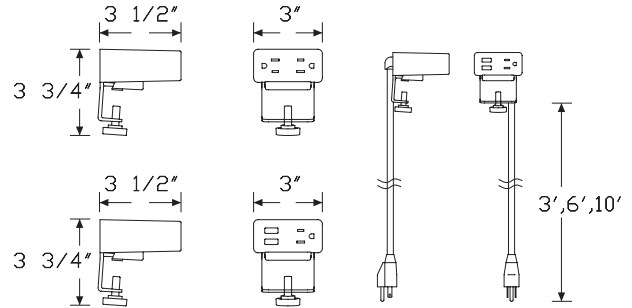

**Surface Clamp**

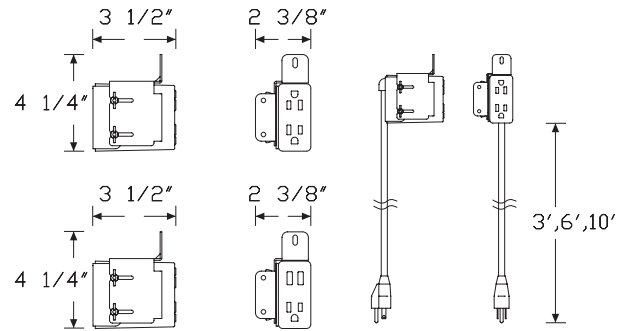

**Grommet Mount**

**Specification Information**

Step 1.

**Y1414.**  A

Step 2. Configuration

**J** 1 simplex receptacles, 2 powered USB  A

**K** 2 simplex receptacles  A

Step 3. Cord/Conduit Length

**03** 3' cord/conduit  A

**06** 6' cord/conduit  A

**10** 10' cord/conduit  A

Step 4. Attachment

**G** grommet mount  A

**S** surface clamp  A

Prices for Steps 1-4.

|                 |           | <b>G</b> | <b>S</b> |
|-----------------|-----------|----------|----------|
| <b>Y1414. J</b> | <b>03</b> | \$332    | 332      |
|                 | <b>06</b> | \$332    | 332      |
|                 | <b>10</b> | \$342    | 342      |
|                 | <hr/>     |          |          |
| <b>K</b>        | <b>03</b> | \$185    | 185      |
|                 | <b>06</b> | \$185    | 185      |
|                 | <b>10</b> | \$195    | 195      |

Step 5. Finish

**91** white  A +\$0

**98** studio white  A +\$0

**G1** graphite  A +\$0

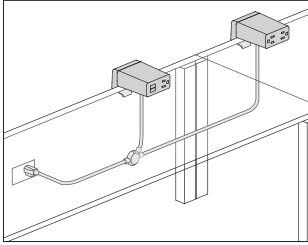

**Product Information**

**Description**

This electrical distributor plugs directly into floor, wall, or ceiling drop outlets. Each module configuration presents the same visual appearance. Cable clips and attachment hardware included. Product is ETL listed to UL962.

**Notes**

Cable clips for cord management are intended for a 1-time installation.

Clamp versions can be reoriented in the field by a technician.

Jumper length denotes distance between center points of each split point.

Cord length denotes distance from plug end to first split point.

All branch lengths from main power cord to module are 12".

A small LED light illuminates through the USB ports when the USB version is plugged in and powered.

USB ports provide 10-watt power to charge most devices and tablets at full speed.

The cord head contains a circuit breaker when there are more than 3 simplex receptacles.

Grommet mount attachment (Y1415.xxxxG) does not come with the mini grommet. Order Logic mini grommet (Y1412.) separately, as needed.

**Dimensions**

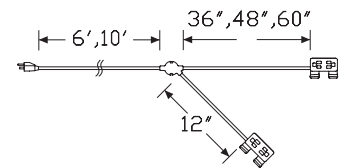
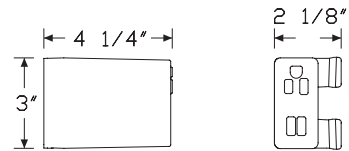

Two Power Modules

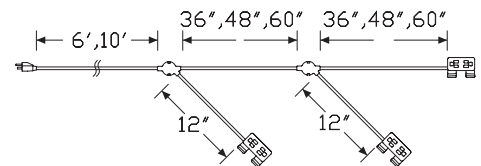

Three Power Modules

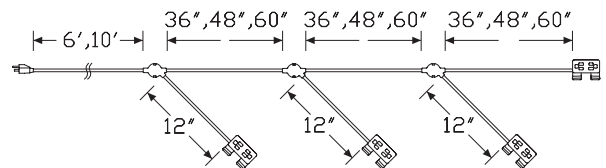

Four Power Modules

Everywhere™ Accessories

**Specification Information**

Step 1.

**Y1415.**  A

Step 2. Number of Modules

- 2** two power modules  A
- 3** three power modules  A
- 4** four power modules  A

Step 3. Power Type

- J** 1 simplex receptacles, 2 powered USB, all modules  A
- K** 2 simplex receptacles, all modules  A
- L** first module has 1 AC plus 2 powered USB all other modules have all AC simplexes  A

Step 4. Jumper Length

- 36** 36" between split points  A
- 48** 48" between split points  A
- 60** 60" between split points  A

Step 5. Attachment

- G** grommet mount  A
- S** surface clamp  A

Step 6. Cord/Conduit Length

- 06** 6' cord/conduit  A
- 10** 10' cord/conduit  A

Prices for Steps 1-6.

|                 |          | <b>36G06</b> | <b>36G10</b> | <b>36S06</b> | <b>36S10</b> | <b>48G06</b> | <b>48G10</b> |
|-----------------|----------|--------------|--------------|--------------|--------------|--------------|--------------|
| <b>Y1415. 2</b> | <b>J</b> | \$736        | 746          | 736          | 746          | 744          | 754          |
|                 | <b>K</b> | \$441        | 451          | 441          | 451          | 449          | 459          |
|                 | <b>L</b> | \$588        | 599          | 588          | 599          | 597          | 607          |
| <b>3</b>        | <b>J</b> | \$1096       | 1106         | 1096         | 1106         | 1112         | 1122         |
|                 | <b>K</b> | \$669        | 680          | 669          | 680          | 686          | 696          |
|                 | <b>L</b> | \$817        | 827          | 817          | 827          | 833          | 844          |
| <b>4</b>        | <b>J</b> | \$1488       | 1499         | 1488         | 1499         | 1513         | 1523         |
|                 | <b>K</b> | \$898        | 908          | 898          | 908          | 923          | 933          |
|                 | <b>L</b> | \$1046       | 1056         | 1046         | 1056         | 1070         | 1080         |
|                 |          | <b>48S06</b> | <b>48S10</b> | <b>60G06</b> | <b>60G10</b> | <b>60S06</b> | <b>60S10</b> |
| <b>Y1415. 2</b> | <b>J</b> | \$744        | 754          | 752          | 763          | 752          | 763          |
|                 | <b>K</b> | \$449        | 459          | 457          | 467          | 457          | 467          |
|                 | <b>L</b> | \$597        | 607          | 605          | 615          | 605          | 615          |
| <b>3</b>        | <b>J</b> | \$1112       | 1122         | 1129         | 1139         | 1129         | 1139         |
|                 | <b>K</b> | \$686        | 696          | 702          | 712          | 702          | 712          |
|                 | <b>L</b> | \$833        | 844          | 850          | 860          | 850          | 860          |

|          |          |        |      |      |      |      |      |
|----------|----------|--------|------|------|------|------|------|
| <b>4</b> | <b>J</b> | \$1513 | 1523 | 1548 | 1558 | 1548 | 1558 |
|          | <b>K</b> | \$923  | 933  | 947  | 957  | 947  | 957  |
|          | <b>L</b> | \$1070 | 1080 | 1095 | 1105 | 1095 | 1105 |

Step 7. Finish

- 91** white  A +\$0
- 98** studio white  A +\$0
- G1** graphite  A +\$0

# Logic C1000 Universal Clamp Mount Distributor

Y1423.

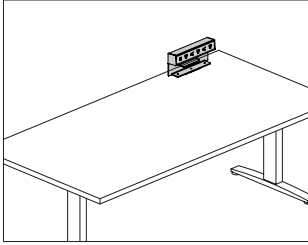

## Product Information

### Description

This Logic Power Access Solutions™ clamp mounted electrical distributor comes in several widths and configurations of simplex receptacles and USB charging ports. The unit is powered using a standard power cord with plug end or a hard-wired connection with electrical conduit. Data cords can be routed through the integrated opening at the rear of the unit. Product is UL listed.

### Notes

Clamp mounts on worksurfaces 1"-1 1/4" thick.

Faceplate color matches unit color.

Simplex receptacles have alternating orientation and greater than normal plug spacing to accommodate most plug types.

USB ports supply 10-watt power and will charge most small electronic devices. Software in each device controls that devices ability to accept a charge via USB.

## Dimensions

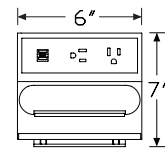
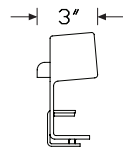

2 simplex receptacles, 2 powered USB

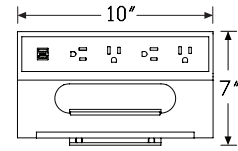
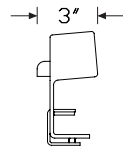

4 simplex receptacles, 2 powered USB

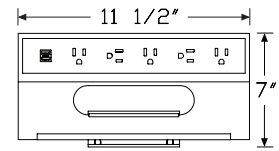
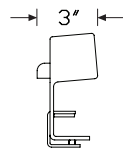

5 simplex receptacles, 2 powered USB

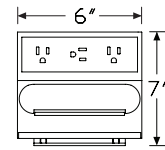
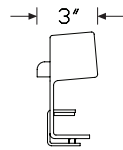

3 simplex receptacles

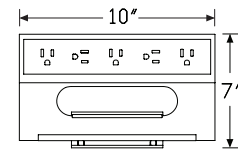
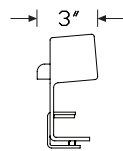

5 simplex receptacles

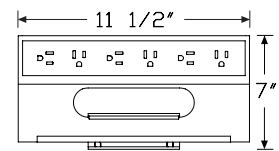
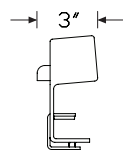

6 simplex receptacles

# Logic C1000 Universal Clamp Mount Distributor *continued*

Everywhere™ Accessories

## Specification Information

### Step 1.

**Y1423.**  A

### Step 2. Configuration

- A** 2 simplex receptacles, 2 powered USB  A
- C** 4 simplex receptacles, 2 powered USB  A
- D** 5 simplex receptacles, 2 powered USB  A
- E** 3 simplex receptacles  A
- F** 5 simplex receptacles  A
- G** 6 simplex receptacles  A

### Step 3. Power Type

- A** power cord with plug end  A
- B** conduit with open end, for hard-wiring  A

### Step 4. Cord/Conduit Length

- 03** 3' cord/conduit  A
- 06** 6' cord/conduit  A
- 10** 10' cord/conduit  A

### Prices for Steps 1-4.

|                 |          | <b>03</b> | <b>06</b> | <b>10</b> |
|-----------------|----------|-----------|-----------|-----------|
| <b>Y1423. A</b> | <b>A</b> | \$449     | 449       | 459       |
|                 | <b>B</b> | \$498     | 498       | 508       |
| <b>C</b>        | <b>A</b> | \$539     | 539       | 549       |
|                 | <b>B</b> | \$588     | 588       | 599       |
| <b>D</b>        | <b>A</b> | \$577     | 577       | 587       |
|                 | <b>B</b> | \$626     | 626       | 637       |
| <b>E</b>        | <b>A</b> | \$301     | 301       | 312       |
|                 | <b>B</b> | \$351     | 351       | 361       |
| <b>F</b>        | <b>A</b> | \$392     | 392       | 402       |
|                 | <b>B</b> | \$441     | 441       | 451       |
| <b>G</b>        | <b>A</b> | \$429     | 429       | 440       |
|                 | <b>B</b> | \$479     | 479       | 489       |

### Step 5. Finish

- 91** white  A +\$0
- 98** studio white  A +\$0
- G1** graphite  A +\$0
- MS** metallic silver  A +\$0



# Logic G1000 Grommet Mounted Electrical Distributor

Y1425.

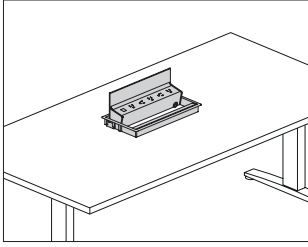

## Product Information

### Description

This Logic Power Access Solutions™ grommet mounted electrical distributor comes in several widths and configurations of simplex receptacles and USB charging ports. The unit is powered using a standard power cord with plug end, a hard-wired connection with electrical conduit, or an IEC connector when used with Renew™ Sit-to-Stand tables. An integrated cord keeper at the face of the unit captures data cords. The unit pivots from a closed position to 135° allowing easy access to power and data cords stored beneath the unit. Product is UL listed.

### Notes

Field cutting of grommet cutout is possible.

IEC connector for Renew power type (C) includes short cord designed to connect to the Renew table power cord through-leg option. Actual cord length may vary.

Simplex receptacles have alternating orientation and greater than normal plug spacing to accommodate most plug types.

USB ports supply 10-watt power and will charge most small electronic devices. Software in each device controls that devices ability to accept a charge via USB.

Refer to Renew™ Sit-to-Stand Tables and Locale® planning guides for specific application information.

20' cord/conduit length (20) is recommended for Exclave® applications.

## Dimensions

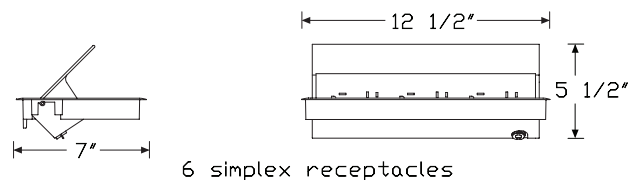
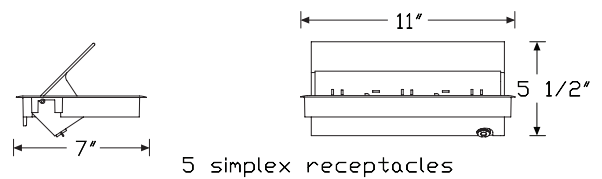
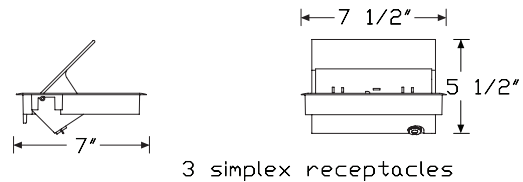
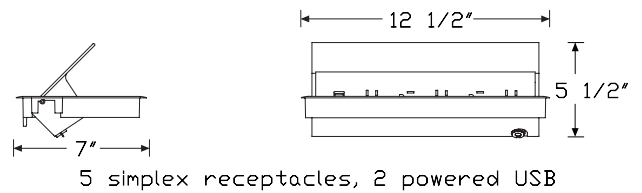
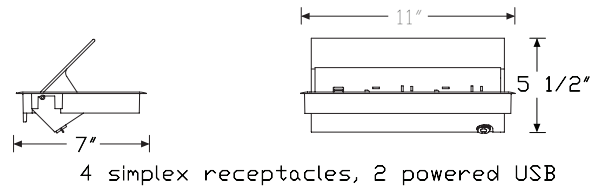
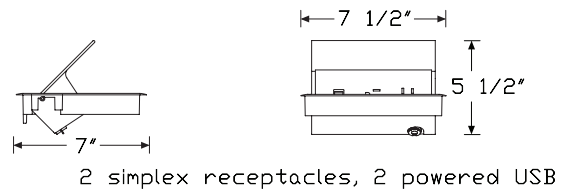

# Logic G1000 Grommet Mounted Electrical Distributor *continued*

## Specification Information

### Step 1.

**Y1425.**  A

### Step 2. Configuration

- A** 2 simplex receptacles, 2 powered USB  A
- C** 4 simplex receptacles, 2 powered USB  A
- D** 5 simplex receptacles, 2 powered USB  A
- E** 3 simplex receptacles  A
- F** 5 simplex receptacles  A
- G** 6 simplex receptacles  A

### Step 3. Power Type

- A** power cord with plug end  A
- B** conduit with open end, for hard-wiring  A
- C** IEC connector for Renew Tables  A

### Step 4. Cord/Conduit Length

#### For power cord with plug end (A)

- 03** 3' cord/conduit  A
- 06** 6' cord/conduit  A
- 10** 10' cord/conduit  A

#### For conduit with open end, for hard-wiring (B)

- 03** 3' cord/conduit  A
- 06** 6' cord/conduit  A
- 10** 10' cord/conduit  A

#### For IEC connector for Renew Tables (C)

- 03** 3' cord/conduit  A

### Prices for Steps 1-4.

|                 |          | 03    | 06  | 10  |
|-----------------|----------|-------|-----|-----|
| <b>Y1425. A</b> | <b>A</b> | \$639 | 639 | 649 |
|                 | <b>B</b> | \$688 | 688 | 698 |
|                 | <b>C</b> | \$649 | —   | —   |
| <b>C</b>        | <b>A</b> | \$741 | 741 | 751 |
|                 | <b>B</b> | \$790 | 790 | 801 |
|                 | <b>C</b> | \$751 | —   | —   |
| <b>D</b>        | <b>A</b> | \$807 | 807 | 817 |
|                 | <b>B</b> | \$856 | 856 | 866 |
|                 | <b>C</b> | \$817 | —   | —   |
| <b>E</b>        | <b>A</b> | \$491 | 491 | 501 |
|                 | <b>B</b> | \$540 | 540 | 550 |
|                 | <b>C</b> | \$501 | —   | —   |

|          |          |       |     |     |
|----------|----------|-------|-----|-----|
| <b>F</b> | <b>A</b> | \$593 | 593 | 604 |
|          | <b>B</b> | \$643 | 643 | 653 |
|          | <b>C</b> | \$604 | —   | —   |
| <b>G</b> | <b>A</b> | \$659 | 659 | 669 |
|          | <b>B</b> | \$708 | 708 | 719 |
|          | <b>C</b> | \$669 | —   | —   |

### Step 5. Finish

|           |  |  |  |      |
|-----------|--|--|--|------|
| <b>91</b> | white <input type="checkbox"/> A           |  |  | +\$0 |
| <b>98</b> | studio white <input type="checkbox"/> A    |  |  | +\$0 |
| <b>G1</b> | graphite <input type="checkbox"/> A        |  |  | +\$0 |
| <b>MS</b> | metallic silver <input type="checkbox"/> A |  |  | +\$0 |

# Logic Mini Grommet

Y1412.

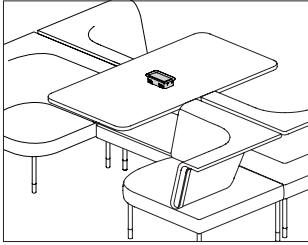

### Product Information

#### Description

This Logic Power Access Solutions™ plastic grommet is available in mini rectangle or mini square configuration. The integrated flaps can hide the things below the surface while also retaining power and data cords.

#### Notes

This grommet is installed in some HermanMiller applications. Verify your application before ordering grommet separately.

#### Dimensions

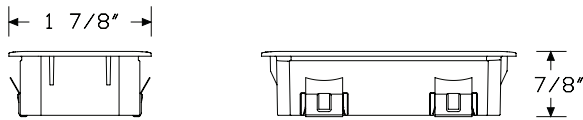
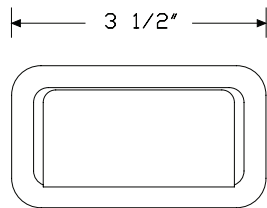

Grommet - Rectangle

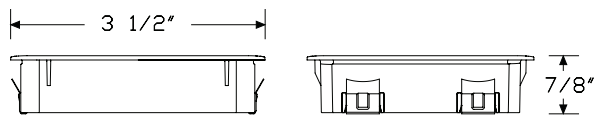
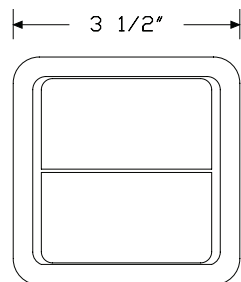

Grommet - Square

### Specification Information

#### Step 1.

**Y1412.**

#### Step 2. Configuration

- 1 mini rectangle grommet
- 2 mini square grommet

#### Prices for Steps 1-2.

|                 |      |
|-----------------|------|
| <b>Y1412. 1</b> | \$26 |
| 2               | \$30 |

#### Step 3. Finish

|           |              |      |
|-----------|--------------|------|
| <b>91</b> | white        | +\$0 |
| <b>98</b> | studio white | +\$0 |
| <b>G1</b> | graphite     | +\$0 |

# Connect™-Ganging Bracket Kit

Y1338.

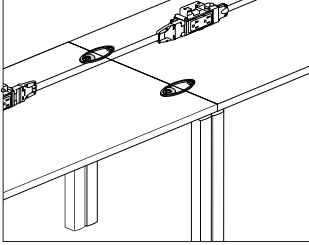

### Product Information

**Description**  
This kit has 2 clips that attach to the underside of 2 adjacent surfaces, ganging them together to provide stability and allowing electrical components to be routed from 1 surface to another. Finish is black.

**Notes**  
Ganging bracket kit should not be used on 18"-deep Everywhere™ tables.

### Dimensions

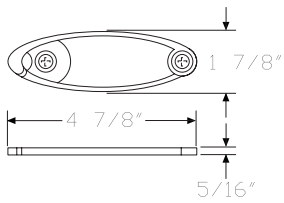

Everywhere™ Accessories

### Specification Information

**Step 1.**  
**Y1338.** \$75

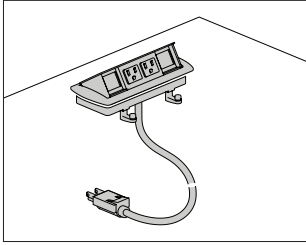

**Product Information**

**Description**

This electrical distributor mounts flush in a surface and has a one-touch pop-up mechanism for accessing power and data. It has 2 simplex receptacles and 2 data openings, and is available with a power cord with plug end, or electrical conduit for hardwire connection. A voice/data adapter kit is included, allowing the data openings to accept various manufacturers' couplers and jacks. Attachment hardware and cord/cable clips are also included. Product is UL listed.

**Notes**

Field cutting of surface may be required. Information on surface cutout size is included on instruction sheet.

Distributor with PVC-free wiring option (LZ) is Cradle to Cradle Silver Certified.

**Dimensions**

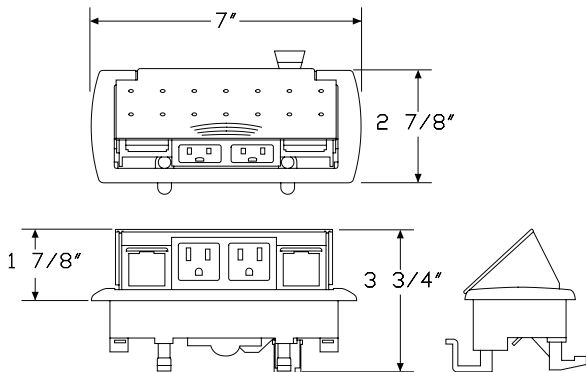

**Specification Information**

**Step 1.**

**Y1321.**

**Step 2. Power Type**

- A** power cord with plug end
- B** conduit with open end, for hard-wiring

**Step 3. Cord/Conduit Length**

- 03** 3' cord/conduit
- 06** 6' cord/conduit
- 10** 10' cord/conduit
- 20** 20' cord/conduit

**Prices for Steps 1-3.**

|                 | <b>03</b> | <b>06</b> | <b>10</b> | <b>20</b> |
|-----------------|-----------|-----------|-----------|-----------|
| <b>Y1321. A</b> | \$199     | 199       | 208       | 255       |
| <b>B</b>        | \$251     | 251       | 260       | 308       |

**Step 4. Wiring Type**

- 4Z** standard +\$0
- LZ** PVC-free +\$39

**Step 5. Finish**

- 0H** black +\$0

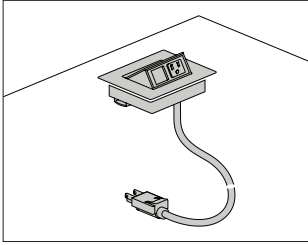

**Product Information**

**Description**

This electrical distributor mounts flush in a surface and has a one-touch pop-up mechanism for accessing power and data. It can be configured with 2 simplex receptacles, or 1 simplex receptacle and 1 data opening. The distributor is available with a power cord with plug end, or electrical conduit for hardwire connection. A voice/data adapter kit is included, allowing the data openings to accept various manufacturers' couplers and jacks. Attachment hardware and cord/cable clips are also included. Product is UL listed.

**Notes**

Field cutting of surface may be required. Information on surface cutout size is included on instruction sheet.

Distributor with PVC-free wiring option (LZ) is Cradle to Cradle Silver Certified.

Distributor with silver finish option (oI) or white finish option (oJ) and standard wiring (4Z) has painted metal trim with white plastic simplex/data interior. Distributor with black finish option (oH) and standard wiring (4Z) has black painted trim with black plastic simplex/data interior. Distributor with PVC-free wiring option (LZ) has black plastic simplex/data interior, regardless of the finish color.

**Dimensions**

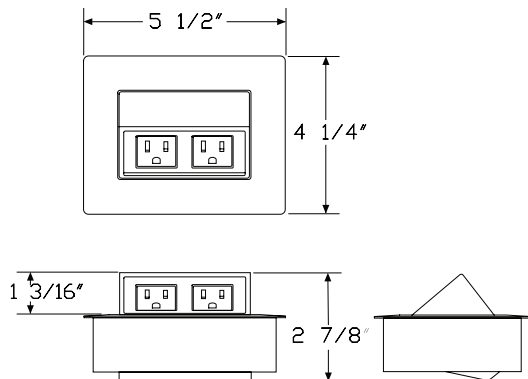

**Specification Information**

**Step 1.**

**Y1322.**

**Step 2. Configuration**

- 1** 1 simplex receptacle, 1 data opening
- 2** 2 simplex receptacles

**Step 3. Power Type**

- A** power cord with plug end
- B** conduit with open end, for hard-wiring

**Step 4. Cord/Conduit Length**

- 03** 3' cord/conduit
- 06** 6' cord/conduit
- 10** 10' cord/conduit
- 20** 20' cord/conduit

**Prices for Steps 1-4.**

|                 |          | <b>03</b> | <b>06</b> | <b>10</b> | <b>20</b> |
|-----------------|----------|-----------|-----------|-----------|-----------|
| <b>Y1322. 1</b> | <b>A</b> | \$237     | 237       | 246       | 293       |
|                 | <b>B</b> | \$288     | 288       | 297       | 343       |
| <b>2</b>        | <b>A</b> | \$251     | 251       | 260       | 308       |
|                 | <b>B</b> | \$302     | 302       | 313       | 360       |

**Step 5. Wiring Type**

- 4Z** standard +\$0
- LZ** PVC-free +\$39

**Step 6. Finish**

- oH** black +\$0
- oI** silver +\$0
- oJ** white +\$0

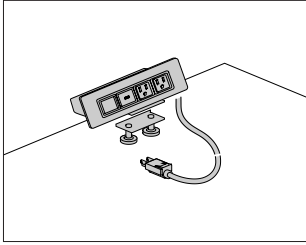

**Product Information**

**Description**

This electrical distributor can grommet-mount flush in a surface, or clamp-mount to the edge. It can be configured with 2 simplex receptacles and 2 data openings, or 3 simplex receptacles and 3 data openings. The distributor is available with a power cord with plug end, or electrical conduit for hardwire connection. A voice/data adapter kit is included, allowing the data openings to accept various manufacturers' couplers and jacks. Attachment hardware and cord/cable clips are also included. Product is UL listed.

**Notes**

Field cutting of surface may be required. Information on surface cutout size is included on instruction sheet.  
 Silver option (OI) and white option (OJ) have painted metal trim with white plastic simplex/data interiors. Black option (OH) has black painted trim with black plastic simplex/data interior.  
 Overall width for distributor with 2 simplex receptacles, 2 data openings option (3) is 8" wide. Overall width for distributor with 3 simplex receptacles, 3 data openings option (4) is 11" wide.

**Dimensions**

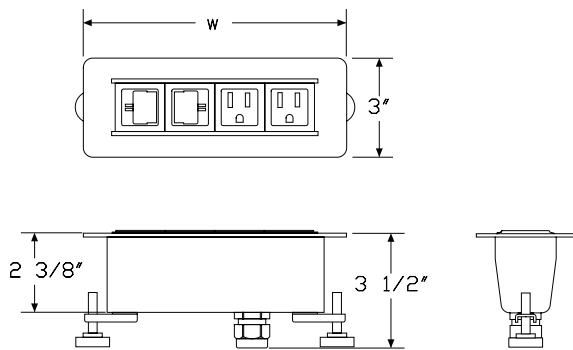

**Specification Information**

**Step 1.**

**Y1323.**

**Step 2. Configuration**

- 3** 2 simplex receptacles, 2 data openings
- 4** 3 simplex receptacles, 3 data openings

**Step 3. Power Type**

- A** power cord with plug end
- B** conduit with open end, for hard-wiring

**Step 4. Cord/Conduit Length**

- 03** 3' cord/conduit
- 06** 6' cord/conduit
- 10** 10' cord/conduit
- 20** 20' cord/conduit

**Step 5. Attachment**

- G** grommet mount
- S** surface clamp

**Prices for Steps 1-5.**

|                       |          |  | <b>03G</b> | <b>03S</b> | <b>06G</b> | <b>06S</b> | <b>10G</b> | <b>10S</b> |      |
|-----------------------|----------|--|------------|------------|------------|------------|------------|------------|------|
| <b>Y1323. 3</b>       | <b>A</b> |  | \$271      | 271        | 271        | 271        | 280        | 280        |      |
|                       | <b>B</b> |  | \$322      | 322        | 322        | 322        | 331        | 331        |      |
| <b>4</b>              | <b>A</b> |  | \$337      | 337        | 337        | 337        | 346        | 346        |      |
|                       | <b>B</b> |  | \$390      | 390        | 390        | 390        | 400        | 400        |      |
|                       |          |  |            |            | <b>20G</b> | <b>20S</b> |            |            |      |
| <b>Y1323. 3</b>       | <b>A</b> |  |            |            |            |            | \$327      | 327        |      |
|                       | <b>B</b> |  |            |            |            |            | \$377      | 377        |      |
| <b>4</b>              | <b>A</b> |  |            |            |            |            | \$395      | 395        |      |
|                       | <b>B</b> |  |            |            |            |            | \$446      | 446        |      |
| <b>Step 6. Finish</b> |          |  |            |            |            |            |            |            |      |
| <b>OH</b>             | black    |  |            |            |            |            |            |            | +\$0 |
| <b>OI</b>             | silver   |  |            |            |            |            |            |            | +\$0 |
| <b>OJ</b>             | white    |  |            |            |            |            |            |            | +\$0 |

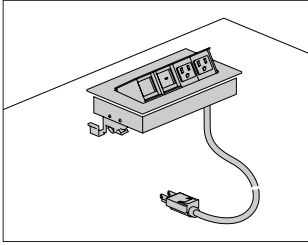

**Product Information**

**Description**

This electrical distributor mounts flush in a surface and has a one-touch pop-up mechanism for accessing power and data. It can be configured with 2 simplex receptacles and 2 data openings, or 3 simplex receptacles and 4 data openings. The distributor is available with a power cord with plug end, or electrical conduit for hardwire connection. A voice/data adapter kit is included, allowing the data openings to accept various manufacturers' couplers and jacks. Attachment hardware and cord/cable clips are also included. Product is UL listed.

**Notes**

Field cutting of surface may be required. Information on surface cutout size is included on instruction sheet.

Distributor with PVC-free wiring option (LZ) is Cradle to Cradle Silver Certified.

Distributor with silver anodized finish option (oK) and standard wiring (4Z) has anodized trim with white plastic simplex/data interior. Distributor with silver anodized finish option (oK) and PVC-free wiring (LZ) has anodized trim with black plastic simplex/data interior.

Overall width for distributor with 2 simplex receptacles, 2 data openings option (3) is 8 3/4" wide. Overall width for distributor with 3 simplex receptacles, 4 data openings option (5) is 12 3/4" wide.

**Dimensions**

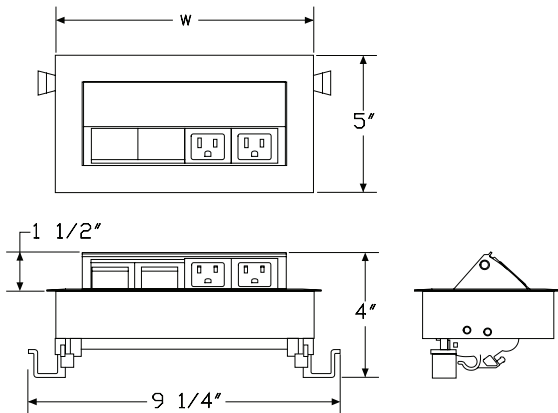

**Specification Information**

**Step 1.**

**Y1324.**

**Step 2. Configuration**

- 3** 2 simplex receptacles, 2 data openings
- 5** 3 simplex receptacles, 4 data openings

**Step 3. Power Type**

- A** power cord with plug end
- B** conduit with open end, for hard-wiring

**Step 4. Cord/Conduit Length**

- 03** 3' cord/conduit
- 06** 6' cord/conduit
- 10** 10' cord/conduit
- 20** 20' cord/conduit

**Prices for Steps 1-4.**

|                 |          | <b>03</b> | <b>06</b> | <b>10</b> | <b>20</b> |
|-----------------|----------|-----------|-----------|-----------|-----------|
| <b>Y1324. 3</b> | <b>A</b> | \$377     | 377       | 386       | 434       |
|                 | <b>B</b> | \$429     | 429       | 440       | 486       |
| <b>5</b>        | <b>A</b> | \$485     | 485       | 495       | 541       |
|                 | <b>B</b> | \$537     | 537       | 543       | 589       |

**Step 5. Wiring Type**

- 4Z** standard +\$0
- LZ** PVC-free +\$39

**Step 6. Finish**

- OK** silver anodized +\$0



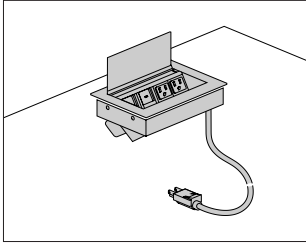

**Product Information**

**Description**

This electrical distributor mounts flush in a surface and has a flip-up lid for accessing power and data from above or below the surface. The flip lid can be closed once devices are connected for a clean visual appearance. It can be configured with 2 simplex receptacles and 2 data openings, or 3 simplex receptacles and 3 data openings. The distributor is available with a power cord with plug end, or electrical conduit for hardwire connection. A voice/data adapter kit is included, allowing the data openings to accept various manufacturers' couplers and jacks. Attachment hardware and cord/cable clips are also included. Product is UL listed.

**Notes**

Field cutting of surface may be required. Information on surface cutout size is included on instruction sheet.

Silver anodized option (oK) has anodized trim with white plastic simplex/data interior.

Overall width for distributor with 2 simplex receptacles, 2 data openings option (3) is 8<sup>3</sup>/<sub>8</sub>" wide. Overall width for distributor with 3 simplex receptacles, 3 data openings option (4) is 11<sup>3</sup>/<sub>8</sub>" wide.

**Dimensions**

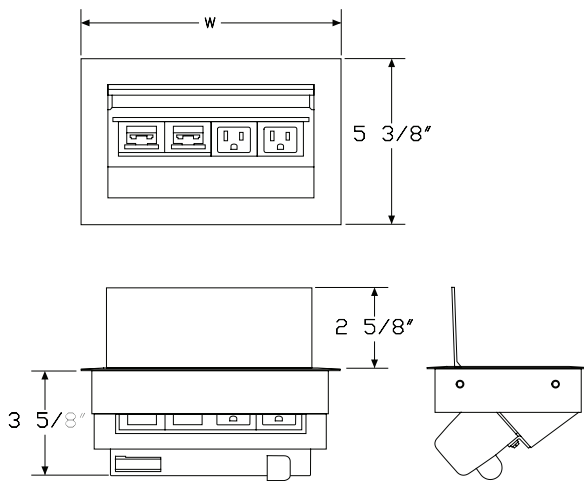

**Specification Information**

**Step 1.**

**Y1325.**

**Step 2. Configuration**

- 3** 2 simplex receptacles, 2 data openings
- 7** 3 simplex receptacles, 3 data openings

**Step 3. Power Type**

- A** power cord with plug end
- B** conduit with open end, for hard-wiring

**Step 4. Cord/Conduit Length**

- 03** 3' cord/conduit
- 06** 6' cord/conduit
- 10** 10' cord/conduit
- 20** 20' cord/conduit

**Prices for Steps 1-4.**

|                 |          | <b>03</b> | <b>06</b> | <b>10</b> | <b>20</b> |
|-----------------|----------|-----------|-----------|-----------|-----------|
| <b>Y1325. 3</b> | <b>A</b> | \$445     | 445       | 454       | 501       |
|                 | <b>B</b> | \$497     | 497       | 506       | 552       |
| <b>7</b>        | <b>A</b> | \$511     | 511       | 522       | 569       |
|                 | <b>B</b> | \$563     | 563       | 574       | 620       |

**Step 5. Finish**

- OK** silver anodized +\$0

Connect™ - S710 - Connect Single  
Circuit Power Unit Y1371.

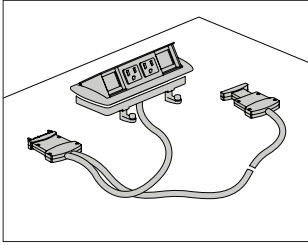

**Product Information**

**Description**

This dedicated modular single circuit electrical distributor mounts flush in a surface and has a one-touch pop-up mechanism for accessing power and data. It has 2 simplex receptacles and 2 data openings and a 60" cord. A maximum of 8 single circuit electrical distributors can be daisy chained per power entry. A voice/data adapter kit is included, allowing the data openings to accept various manufacturers couplers and jacks. Attachment hardware and cord/cable clips are also included.

**Notes**

Field cutting of surface may be required. For information on surface cutout size, see included instruction sheet.

UL listed when used in conjunction with most Everywhere™ fixed height tables.

To gang tables together per electrical code requirements, order ganging bracket kit (Y1338.) separately.

Order single circuit power entry (Y1377.) separately.

Where lengths of greater than 60" are needed, order single circuit jumpers (Y1378.) separately. Each single circuit jumper counts toward the 8 allowed electrical distributors per power entry.

**Dimensions**

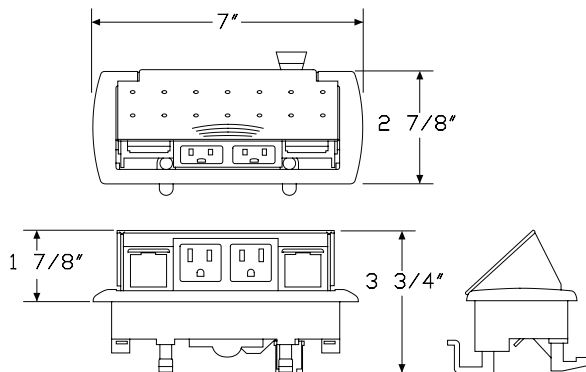

**Specification Information**

**Step 1.**

**Y1371.**

**Step 2. Configuration**

**3** 2 simplex receptacles, 2 data openings

**Step 3. Cord Length**

**60** 60" long

**Prices for Steps 1-3.**

|                 |              |
|-----------------|--------------|
|                 | <b>60</b>    |
| <b>Y1371. 3</b> | <b>\$310</b> |

**Step 4. Finish**

|                 |             |
|-----------------|-------------|
| <b>0H</b> black | <b>+\$0</b> |
|-----------------|-------------|

Connect™ - S720 - Connect Single Circuit Power Unit Y1372.

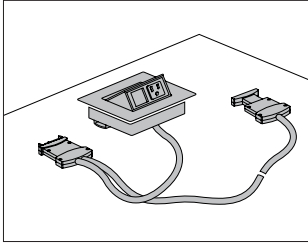

**Product Information**

**Description**

This dedicated modular single circuit electrical distributor mounts flush in a surface and has a one-touch pop-up mechanism for accessing power and data. It can be configured with 2 simplex receptacles, or 1 simplex receptacle and 1 data opening. Cord length is 60". A maximum of 8 single circuit electrical distributors can be daisy chained per power entry. A voice/data adapter kit is included, allowing the data openings to accept various manufacturers couplers and jacks. Attachment hardware and cord/cable clips are also included.

**Notes**

Field cutting of surface may be required. For information on surface cutout size, see included instruction sheet.  
 UL listed when used in conjunction with most Everywhere™ fixed height tables.  
 To gang tables together per electrical code requirements, order ganging bracket kit (Y1338.) separately.  
 Order single circuit power entry (Y1377.) separately.  
 Where lengths of greater than 60" are needed, order single circuit jumpers (Y1378.) separately. Each single circuit jumper counts toward the 8 allowed electrical distributors per power entry.  
 Silver option (oI) and white option (oJ) have painted metal trim with white plastic simplex/data interiors. Black option (oH) has black painted trim with black plastic simplex/data interior.

**Dimensions**

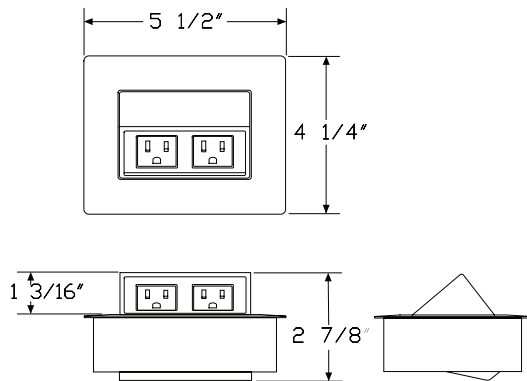

**Specification Information**

**Step 1.**

**Y1372.**

**Step 2. Configuration**

- 1 1 simplex receptacle, 1 data opening
- 2 2 simplex receptacles

**Step 3. Cord Length**

**60** 60" long

**Prices for Steps 1-3.**

|                 |           |
|-----------------|-----------|
|                 | <b>60</b> |
| <b>Y1372. 1</b> | \$346     |
| <b>2</b>        | \$361     |

**Step 4. Finish**

|           |        |      |
|-----------|--------|------|
| <b>oH</b> | black  | +\$0 |
| <b>oI</b> | silver | +\$0 |
| <b>oJ</b> | white  | +\$0 |

Everywhere™ Accessories

# Connect™ - S730 - Connect Single Circuit Power Unit Y1373.

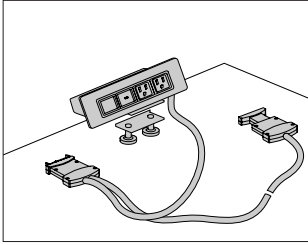

## Product Information

### Description

This dedicated modular single circuit electrical distributor mounts flush in a surface or with an edge clamp mount. It has 2 simplex receptacles and 2 data openings, and a 60" cord. A maximum of 8 single circuit electrical distributors can be daisy chained per power entry. A voice/data adapter kit is included, allowing the data openings to accept various manufacturers couplers and jacks. Attachment hardware and cord/cable clips are also included.

### Notes

Field cutting of surface may be required. For information on surface cutout size, see included instruction sheet.

UL listed when used in conjunction with most Everywhere™ fixed height tables.

To gang tables together per electrical code requirements, order ganging bracket kit (Y1338.) separately.

Order single circuit power entry (Y1377.) separately.

Where lengths of greater than 60" are needed, order single circuit jumpers (Y1378.) separately. Each single circuit jumper counts toward the 8 allowed electrical distributors per power entry.

Silver option (OI) and white option (OJ) have painted metal trim with white plastic simplex/data interiors. Black option (OH) has black painted trim with black plastic simplex/data interior.

## Dimensions

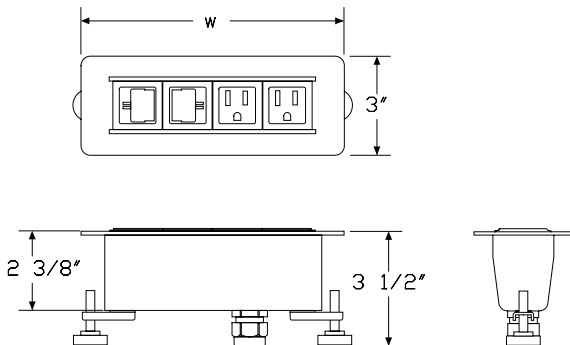

## Specification Information

### Step 1.

**Y1373.**

### Step 2. Configuration

**3** 2 simplex receptacles, 2 data openings

### Step 3. Cord Length

**60** 60" long

### Step 4. Attachment

**G** grommet mount

**S** surface clamp

### Prices for Steps 1-4.

|                 |           | <b>G</b> | <b>S</b> |
|-----------------|-----------|----------|----------|
| <b>Y1373. 3</b> | <b>60</b> | \$390    | 379      |

### Step 5. Finish

|           |        |      |
|-----------|--------|------|
| <b>OH</b> | black  | +\$0 |
| <b>OI</b> | silver | +\$0 |
| <b>OJ</b> | white  | +\$0 |

Connect™ - S740 - Connect Single  
Circuit Power Unit Y1374.

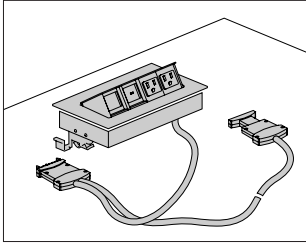

**Product Information**

**Description**

This dedicated modular single circuit electrical distributor mounts flush in a surface and has a one-touch pop-up mechanism for accessing power and data. It has 2 simplex receptacles and 2 data openings, and a 60" cord. A maximum of 8 single circuit electrical distributors can be daisy chained per power entry. A voice/data adapter kit is included, allowing the data openings to accept various manufacturers couplers and jacks. Attachment hardware and cord/cable clips are also included.

**Notes**

Field cutting of surface may be required. For information on surface cutout size, see included instruction sheet.

UL listed when used in conjunction with most Everywhere™ fixed height tables.

To gang tables together per electrical code requirements, order ganging bracket kit (Y1338.) separately.

Order single circuit power entry (Y1377.) separately.

Where lengths of greater than 60" are needed, order single circuit jumpers (Y1378.) separately. Each single circuit jumper counts toward the 8 allowed electrical distributors per power entry.

Silver anodized option (oK) has anodized trim with white plastic simplex/data interior.

Overall width for distributor with 2 simplex receptacles, 2 data openings is 8 1/4" wide.

**Dimensions**

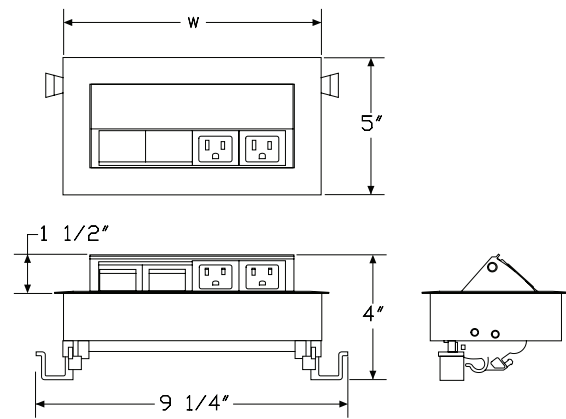

Connect™ - S740 - Connect Single  
 Circuit Power Unit *continued*

**Specification Information**

Step 1.

**Y1374.**

Step 2. Configuration

**3** 2 simplex receptacles, 2 data openings

Step 3. Cord Length

**60** 60" long

Prices for Steps 1-3.

**60**

**Y1374. 3** \$484

Step 4. Finish

**OK** silver anodized +\$0

Everywhere™ Accessories

# Connect™ - S750 - Connect Single Circuit Power Unit Y1375.

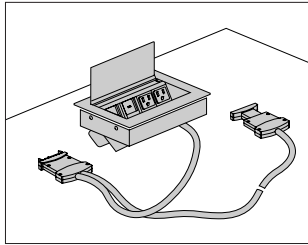

## Product Information

### Description

This dedicated modular single circuit electrical distributor mounts flush in a surface and has a flip-up lid for accessing power and data from above or below the surface. The lid can be closed once devices are connected for a clean visual appearance. The distributor has 2 simplex receptacles and 2 data openings, and a 60" cord. A maximum of 8 single circuit electrical distributors can be daisy chained per power entry. A voice/data adapter kit is included, allowing the data openings to accept various manufacturers couplers and jacks. Attachment hardware and cord/cable clips are also included.

### Notes

Field cutting of surface may be required. For information on surface cutout size, see included instruction sheet.

UL listed when used in conjunction with most Everywhere™ fixed height tables.

To gang tables together per electrical code requirements, order ganging bracket kit (Y1338.) separately.

Order single circuit power entry (Y1377.) separately.

Where lengths of greater than 60" are needed, order single circuit jumpers (Y1378.) separately. Each single circuit jumper counts toward the 8 allowed electrical distributors per power entry.

Silver anodized option (oK) has anodized trim with white plastic simplex/data interior.

Overall width for distributor with 2 simplex receptacles, 2 data openings is 8<sup>3</sup>/<sub>8</sub>" wide.

## Dimensions

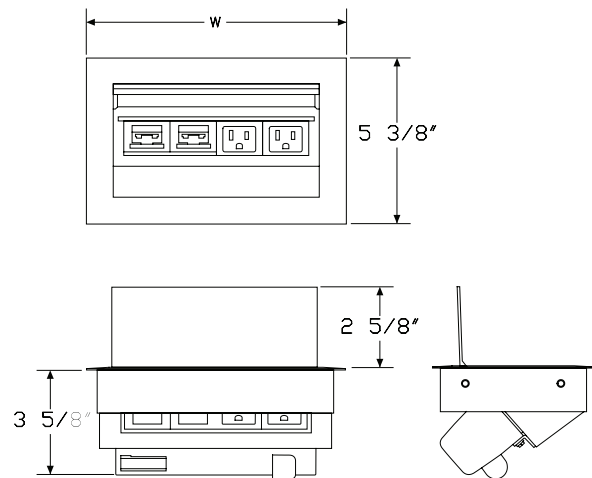

Connect™ - S750 - Connect Single  
 Circuit Power Unit *continued*

**Specification Information**

Step 1.

**Y1375.**

Step 2. Configuration

**3** 2 simplex receptacles, 2 data openings

Step 3. Cord Length

**60** 60" long

Prices for Steps 1-3.

**60**

**Y1375. 3** \$549

Step 4. Finish

**0K** silver anodized +\$0

Everywhere™ Accessories



# Connect™ Single Circuit Electrical Power Entry Y1377.

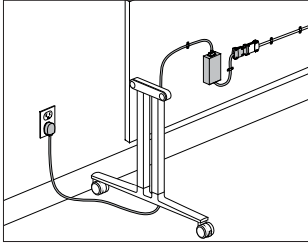

## Product Information

### Description

This standard receptacle 15-amp power entry provides power for single circuit electrical distributors. Up to 8 single circuit modular electrical distributors can be daisy chained and connected in any order. If more than 8 units are connected to this power entry, the system automatically shuts down and a red LED illuminates. A green LED indicates that more units can be connected and the system is ready. Standard attachment hardware is included.

### Notes

UL listed when used in conjunction with most Everywhere™ fixed height tables.

Order electrical distributors (Y1371., Y1372., Y1373., Y1374., Y1375.) and single circuit jumpers (Y1378.) separately.

### Dimensions

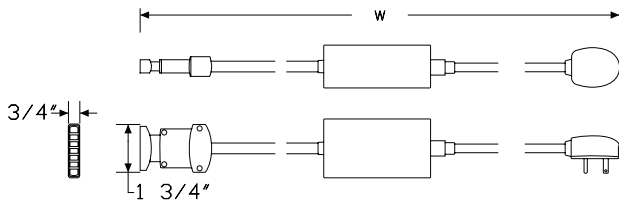

## Specification Information

### Step 1.

**Y1377.**

### Step 2. Cord Length

**06** 6' long  
**10** 10' long

### Prices for Steps 1-2.

|                  |       |
|------------------|-------|
| <b>Y1377. 06</b> | \$443 |
| <b>10</b>        | \$464 |

# Connect™ Single Circuit Electrical By-Pass Jumper Y1378.

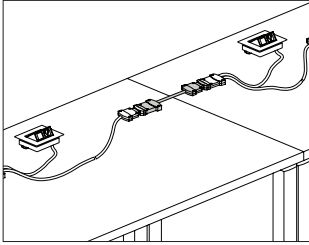

## Product Information

**Description**  
 This electrical jumper provides additional length for the Connect™ single circuit modular electrical system. Jumpers are available in a variety of lengths and count as one of the 8 electrical distributors allowed per power entry.

**Notes**  
 UL listed when used in conjunction with most Everywhere™ fixed height tables.

Order electrical distributors (Y1371., Y1372., Y1373., Y1374., Y1375.) and single circuit power entry (Y1377.) separately.

## Dimensions

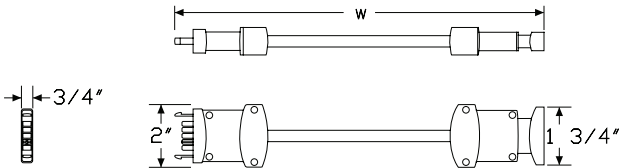

Everywhere™ Accessories

## Specification Information

**Step 1.**  
**Y1378.**

### Step 2. Cord Length

- 12** 12" long
- 24** 24" long
- 36** 36" long
- 48** 48" long
- 60** 60" long

### Prices for Steps 1-2.

|                  |       |
|------------------|-------|
| <b>Y1378. 12</b> | \$91  |
| <b>24</b>        | \$99  |
| <b>36</b>        | \$109 |
| <b>48</b>        | \$117 |
| <b>60</b>        | \$125 |

## Index by Product Name

| <b>Everywhere™ Tables</b>                           |         |
|---|---------|
|   | page(s) |
| Cable Management Clip                               | 89      |
| Cable Management Trough, Work Surface Suspended     | 95      |
| Cable Trough  | 94      |
| Classroom Curve Table                               | 44      |
| Concave Rectangle                                   | 34      |
| Conference Corner Table                             | 48      |
| Connect™ - Ganging Bracket Kit                      | 106     |
| Connect™ - S100                                     | 107, 84 |
| Connect™ - S200                                     | 108, 85 |
| Connect™ - S300                                     | 109, 86 |
| Connect™ - S400                                     | 110, 87 |
| Connect™ - S500                                     | 111, 88 |
| Connect™ - S710 - Connect Single Circuit Power Unit | 112     |
| Connect™ - S720 - Connect Single Circuit Power Unit | 113     |
| Connect™ - S730 - Connect Single Circuit Power Unit | 114     |
| Connect™ - S740 - Connect Single Circuit Power Unit | 115     |
| Connect™ - S750 - Connect Single Circuit Power Unit | 117     |
| Connect™ Single Circuit Electrical By-Pass Jumper   | 120     |
| Connect™ Single Circuit Electrical Power Entry      | 119     |
| Cord Manager  | 96      |
| D-Shaped Table                                      | 23      |
| Fabric Modesty Panel                                | 93      |
| Flip-Top Rectangular Table                          | 54      |
| Logic C1000 Universal Clamp Mount Distributor       | 101, 77 |
| Logic G1000 Grommet Mounted Electrical Distributor  | 103, 79 |
| Logic G1200 Grommet Pass Thru                       | 82      |
| Logic HD Cable Manager                              | 83      |
| Logic Mini  | 97, 73  |
| Logic Mini Grommet                                  | 105, 81 |
| Logic Mini - Vine                                   | 99, 75  |
| Modesty Panel                                       | 91      |
| Occasional Table, Round                             | 70      |
| Occasional Table, Square                            | 67      |
| Oval Table  | 19      |
| Rectangular Table                                   | 5       |
| Round Corner Table                                  | 51      |
| Round Table   | 15      |
| Soft Rectangle - Meeting Table                      | 27      |
| Soft Square Table                                   | 38      |
| Square Table  | 11      |
| Standard-Height Table Base                          | 60      |
| Standard-Height Table Leg                           | 58      |
| Standing-Height Round Table                         | 64      |
| Standing-Height Square Table                        | 61      |
| Tear Drop Table                                     | 41      |
| Vertical Cord Covers                                | 90      |

|                            |    |
|----------------------------|----|
| Video Oval - Meeting Table | 31 |
|----------------------------|----|



# Index by Product Number

|  |  |         |         |
|--|--|---------|---------|
| A0382. Cable Management Trough, Work Surface               |  |         |         |
| Suspended  |  | page(s) | 95      |
| DT1AE. Rectangular Table                                   |  |         | 5       |
| DT1AS.   |  |         |         |
| DT1AT.   |  |         |         |
| DT1BE. Square Table  |  |         | 11      |
| DT1BS.   |  |         |         |
| DT1BT.   |  |         |         |
| DT1CE. Round Table   |  |         | 15      |
| DT1CS.   |  |         |         |
| DT1CT.   |  |         |         |
| DT1DE. Oval Table  |  |         | 19      |
| DT1DS.   |  |         |         |
| DT1DT.   |  |         |         |
| DT1EE. D-Shaped Table                                      |  |         | 23      |
| DT1ES.   |  |         |         |
| DT1ET.   |  |         |         |
| DT1FE. Soft Rectangle - Meeting Table                      |  |         | 27      |
| DT1FS.   |  |         |         |
| DT1FT.   |  |         |         |
| DT1GE. Video Oval - Meeting Table                          |  |         | 31      |
| DT1GS.   |  |         |         |
| DT1GT.   |  |         |         |
| DT1HE. Concave Rectangle                                   |  |         | 34      |
| DT1HS.   |  |         |         |
| DT1HT.   |  |         |         |
| DT1JE. Soft Square Table                                   |  |         | 38      |
| DT1JS.   |  |         |         |
| DT1JT.   |  |         |         |
| DT1KE. Tear Drop Table                                     |  |         | 41      |
| DT1KS.   |  |         |         |
| DT1KT.   |  |         |         |
| DT1LE. Classroom Curve Table                               |  |         | 44      |
| DT1LS.   |  |         |         |
| DT1LT.   |  |         |         |
| DT1ME. Conference Corner Table                             |  |         | 48      |
| DT1MS.   |  |         |         |
| DT1MT.   |  |         |         |
| DT1NE. Round Corner Table                                  |  |         | 51      |
| DT1NS.   |  |         |         |
| DT1NT.   |  |         |         |
| DT2A. Standard-Height Table Leg                            |  |         | 58      |
| DT2B. Standard-Height Table Base                           |  |         | 60      |
| DT3BE. Standing-Height Square Table                        |  |         | 61      |
| DT3BS.   |  |         |         |
| DT3BT.   |  |         |         |
| DT3CE. Standing-Height Round Table                         |  |         | 64      |
| DT3CS.   |  |         |         |
| DT3CT.   |  |         |         |
| DT4BS. Occasional Table, Square                            |  |         | 67      |
| DT4BT.   |  |         |         |
| DT4CS. Occasional Table, Round                             |  |         | 70      |
| DT4CT.   |  |         |         |
| DT5AE. Flip-Top Rectangular Table                          |  |         | 54      |
| DT5AS.   |  |         |         |
| DT5AT.   |  |         |         |
| DT9A. Cable Management Clip                                |  |         | 89      |
| DT9B. Vertical Cord Covers                                 |  |         | 90      |
| FV984. Cord Manager  |  |         | 96      |
| Y1113. Modesty Panel                                       |  |         | 91      |
| Y1114. Fabric Modesty Panel                                |  |         | 93      |
| Y1200. Cable Trough  |  |         | 94      |
| Y1321. Connect™-S100                                       |  |         | 107, 84 |
| Y1322. Connect™-S200                                       |  |         | 108, 85 |
| Y1323. Connect™-S300                                       |  |         | 109, 86 |
| Y1324. Connect™-S400                                       |  |         | 110, 87 |
| Y1325. Connect™-S500                                       |  |         | 111, 88 |
| Y1338. Connect™-Ganging Bracket Kit                        |  |         | 106     |
| Y1371. Connect™ - S710 - Connect Single Circuit Power Unit |  |         | 112     |
| Y1372. Connect™ - S720 - Connect Single Circuit Power Unit |  |         | 113     |
| Y1373. Connect™ - S730 - Connect Single Circuit Power Unit |  |         | 114     |
| Y1374. Connect™ - S740 - Connect Single Circuit Power Unit |  |         | 115     |
| Y1375. Connect™ - S750 - Connect Single Circuit Power Unit |  |         | 117     |
| Y1377. Connect™ Single Circuit Electrical Power Entry      |  |         | 119     |
| Y1378. Connect™ Single Circuit Electrical By-Pass Jumper   |  |         | 120     |
| Y1412. Logic Mini Grommet                                  |  |         | 105, 81 |
| Y1414. Logic Mini  |  |         | 97, 73  |
| Y1415. Logic Mini - Vine                                   |  |         | 99, 75  |
| Y1420. Logic G1200 Grommet Pass Thru                       |  |         | 82      |
| Y1423. Logic C1000 Universal Clamp Mount Distributor       |  |         | 101, 77 |
| Y1424. Logic HD Cable Manager                              |  |         | 83      |
| Y1425. Logic G1000 Grommet Mounted Electrical Distributor  |  |         | 103, 79 |



## 20-Day or Less/Assigned Lead-Time Order Information

### 20-Day or Less and Assigned Lead-Time Programs

20-day or less and assigned lead-time products are designed for established Herman Miller dealers with pre-approved credit.

Products are distributed from multiple manufacturing facilities across the United States. All products and options not designated by an Assigned Lead-Time icon [A] will ship in 20 business days or less after being acknowledged by Herman Miller. Products and options designated by an [A] are on the assigned lead-time program and will ship in 20 days, less than 20 days, or more than 20 days from order acknowledgement.

### Ordering Procedure

Please place orders through Order Manager. If this is not available to you, place orders through mail or fax. Verbal purchase orders will not be accepted.

Order Entry fax number for Passage®, 5000 Series, and Meridian® Filing and Storage: (616) 846 9236.

Order Entry fax number for all other products:  
(616) 654 3085.

For more information, contact your Customer Care representative at:  
(866) 854 3048 EXT 3400.

### Shipments and Delivery

Per Herman Miller Terms and Conditions.

### Changes and Cancellation

Per Herman Miller Terms and Conditions.





# Vary Easy Program

## Program Overview

Vary Easy is a program designed to help dealers specify standard products with a larger breadth of options. For example, depending on the type of product being specified, choices include additional size, finish, edge types, and cable management features. Vary Easy 3D, specIT, and third-party text-based specification packages support the Vary Easy program. Vary Easy 3D enables designers to create a 3D image, CAD symbols, and a price book page. A Vary Easy product number is assigned for each product as the user selects specific options. Once the product is completely specified, the order can be submitted via Kiosk's Order Manager or a dealer's business system.

## Accessing and Specifying Vary Easy

To view the full product vocabulary, go to the Vary Easy Product Offering on Kiosk. To specify Vary Easy, go to the Vary Easy 3D website on Kiosk, specIT, or your third-party text-based specification package.

Once you've made your product line selection, continue to follow through each option and enter the specific options that represent the product you need. When the product is fully specified, Vary Easy will generate an orderable product number and instantly calculate a price.

*Note: Failure to completely specify a product will cause a delay in order acknowledgements. Be sure to make a selection for all options offered.*

The acknowledgement process for Vary Easy products is the same as for any standard order. Vary Easy products ship with a standardized lead time and are competitively priced.

For more information, contact your Customer Care Line at (866) 854 3048 EXT 3400.

For more information about our products and services or to see a list of dealers, please visit us at [HermanMiller.com](http://HermanMiller.com) or call (800) 851 1196.

© 2018 Herman Miller, Inc., Zeeland, Michigan

® **HermanMiller**, ●, Action Office, Aeron, Aside, Avive, Canvas Office Landscape, Caper, Celle, Co/Struc, Eames, Embody, Equa 2, Ergon 3, Ethospace, Exclave, Fine-Tune, FlexFront, Formcoat, Ground Cloth, Herman Miller Healthcare, Layout Studio, Maharam, Meridian, Mirra, Passage, Pellicle, Perspectives, PostureFit, Resolve, Sayl, Setu, Thrive, Tu, Y-Tower, and Z-Axis are among the registered trademarks of Herman Miller, Inc., and its owned subsidiaries.

™ AireWeave, Bubbletack, Cellular Suspension, Compass, Connect, DOT, Durawrap, Everywhere, Flex-Edge, Hopsak 2, Intent, Iota, Keyless Entry, Latitude, Lyris 2, Motia, Multiscrim, Nelson, Renew, Stackable, Swoop, TriFlex, Twist, and Verus are among the trademarks of Herman Miller, Inc., and its owned subsidiaries.

®Chemsurf® is a registered trademark of Wilsonart International.

Corian® is a registered trademark of E.I. du Pont de Nemours and Company Corporation.

FLEXNET™ is a trademark of Milliken & Company.

Floor Saver Glide® is a registered trademark of Carpin Manufacturing, Inc.

Geiger® is a registered trademark of Geiger International.

Microsoft® and Natural® Keyboard are registered trademarks of Microsoft Corporation.

Place Textiles® is a registered trademark of Place Textiles.