

Saya

Design by Lievore Altherr Molina, 2013

Art. 3700

Curved plywood chair with 4 leg base, available in several colors. Glides also provided with felt insert for wood floors.



Dimensions *

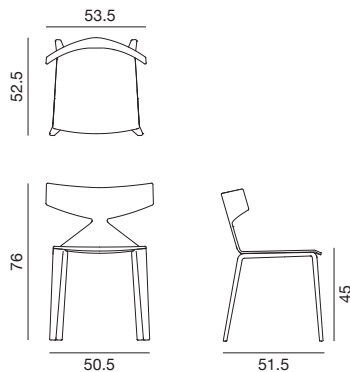

* File CAD 2D - 3D available for download at www.arper.com

Frame Base

arper

Shell

Wood



L0001

L0002

L0003

L0004

L0005

L0006

L0022

L0023

F +39 0422 791800

T +39 0422 7918

www.arper.com

Saya

Design by Lievore Altherr Molina, 2013

SHIPMENT DETAILS

Art.3700

1 pz = 1  - kg 6,72/ m² 0,27

TECHNICAL SPECIFICATIONS

RESISTANCE TEST

- EN 1728:2000 - EN 15373:2007 6.12
- EN 1728:2000 - EN 15373:2007 6.15
- EN 1728:2000 - EN 15373:2007 6.2.1
- EN 1728:2000 - EN 15373:2007 6.7
- EN 1022:05
- EN 1728:2000 - EN 15373:2007 6.13
- EN 1728:2000 - EN 15373:2007 6.16
- EN 1728:2000 - EN 15373:2007 6.2.2
- EN 1728:2000 - EN 15373:2007 6.8

FIRE RETARDANT TEST

ENVIRONMENTAL CERTIFICATIONS



arper

F +39 0422 791800

T +39 0422 7918

www.arper.com

Saya

Design by Lievore Altherr Molina, 2013

Art. 3714

Curved plywood chair with 4 leg base. It is available in several colors and with fabric, leather, faux leather or customer's material upholstered cushion applied on the seat. It is provided with glides with felt insert for wood floors.



Dimensions *

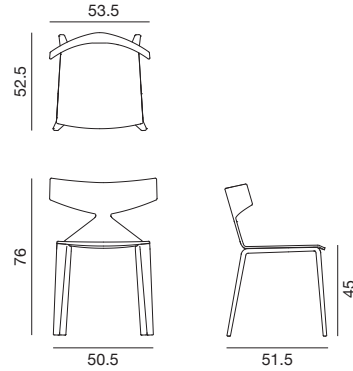

* File CAD 2D - 3D available for download at www.arper.com

Frame Base

Shell

Wood



L0001 L0002 L0003 L0004 L0005 L0006 L0022 L0023

Carded In



kvadrat

camira



DESIGN
TEX



Elmosoft®
Leather

Gabriel



svensson

maharam

Serge Ferrari

arper

F +39 0422 791800

T +39 0422 7918

www.arper.com

Saya

Design by Lievore Altherr Molina, 2013

SHIPMENT DETAILS

Art.3714

1 pz = 1  - kg 6,72/ m³ 0,27

TECHNICAL SPECIFICATIONS

Art.3714

COL requirement m² 0.67

H 140 cm. COM Meterage ml 0.59

RESISTANCE TEST

- EN 1728:2000 - EN 15373:2007 6.12
- EN 1728:2000 - EN 15373:2007 6.2.1
- EN 1728:2000 - EN 15373:2007 6.7
- EN 1728:2012 - EN 16139:2013 6.15
- EN 1022:05
- EN 1728:2000 - EN 15373:2007 6.13
- EN 1728:2000 - EN 15373:2007 6.2.2
- EN 1728:2000 - EN 15373:2007 6.8
- EN 1728:2012 - EN 16139:2013 6.16

FIRE RETARDANT TEST

California TB117-2013 Cava 3 Clara Canvas Divina MD Divina Melange 2 Divina 3 Soft leather Elmosoft Field Hallingdal 65 Jet Jumper 3 Pro 3 Soft leather Pause 4 Remix 2 Savanna Steelcut 2 Scuba Steelcut Trio 2 Steelcut Trio 3 Sunniva Sunniva 2 Tonus 4 Tempo Faux leather Valencia • BS5852 Sch. 5 Part 1 Cava 3 Clara Canvas Divina MD Divina Melange 2 Divina 3 Soft leather Elmosoft Hallingdal 65 Soft leather Remix 2 Savanna Steelcut 2 Steelcut Trio 2 Steelcut Trio 3 Tonus 4 Faux leather Valencia

ENVIRONMENTAL CERTIFICATIONS



arper

F +39 0422 791800

T +39 0422 7918

www.arper.com